

Assemble Me. Fly Me



Find out MORE



  
UGEAR'S®

Mechanical models

**Model «Aviator»  
Модель «Авиатор»**

DEU Modell «Flieger», FRA Modèle «Aviateur»,  
POL Model «Awiator», SPA Modelo «Aviador»,  
ITA Modello «Aviatore», TUR Model «Uçak, helikopter ve kontrol kulesi»,  
RUS Модель «Авиатор», KOR 비행사, CHI «飞行员» 模型

**Assembly instructions  
Інструкція зі складання**

DEU Aufbauanleitung, FRA Notice d'assemblage, POL Instrukcja montażu,  
SPA Instrucciones de montaje, ITA Istruzioni di montaggio, TUR Kurulum talimatı,  
RUS Инструкция по сборке, KOR 조립 설명서, CHI 装配说明书



## ENG

Assembly instructions:  
Remove model parts from the hanger board as illustrated below. Careful not to break parts. If a part does not remove easily, carefully cut it out with a knife. This model is intended for self-assembly without glue. If you have difficulty installing the axles, try waxing them with a regular candle. All moving parts can also be waxed during assembly to reduce friction when operating the model.

## TUR

Kurulum talimatı:  
Şemada işaretlenen parçaları tahtadan çıkarın. Kırılmamasına dikkat ediniz. Parça çıkarılmıyorsa başlangıç yerleri bıçakla kesiniz. Konstruksiyon, yapıştırıcı kullanılmadan yapılmaktadır. Tahta deliğini (kürdan) deliğin içine yerleştirmede zorluk çekiyorsanız önceden dingile veya parçalara mum sürünüz. Hareketli parçaların daha iyi kayması için kurulum sırasında parçalara mum sürünüz.

## UKR

Інструкція зі складання:  
Витягніть з дошки позначені на схемі деталі. Намагайтеся їх не зламати. Якщо деталь не виймається, надсічіть перемички ножем. Конструкція збирається без клею. У разі виникнення труднощів з протягуванням зубчистки (вісі) в отвір, потріть зубчистку об звичайну свічку. Також можна змастити сачною всі деталі механізму, що рухаються, щоб зменшити тертя при обертанні.

## RUS

Инструкция по сборке:  
Вынимайте из доски обозначенные на схеме детали. Старайтесь их не сломать. Если деталь не извлекается, надрежьте перемычки ножом. Конструкция собирается без клея. Если возникли трудности с установкой деревянной оси, перед установкой потрите детали об обычную свечу. Для лучшего скольжения смазывайте движущиеся детали механизма обычной свечой во время сборки.

## DEU

Aufbauanleitung:  
Bitte die in der Zeichnung angegebenen Teile aus der Platte herausnehmen. Versuchen Sie bitte diese nicht zu brechen. Wenn sich ein Teil nicht herausnehmen lässt, schneiden Sie die Stege mit dem Messer leicht an. Das Modell wird ohne Klebstoffe zusammengebaut. Lässt sich eine Achse nur schwer in eine Öffnung einführen, reiben Sie diese mit einer Kerze etwas ein. Für besseres Gleiten schmieren Sie alle beweglichen Teile mit einer Kerze.

## KOR

조립 설명:  
부품이 손상되지 않도록 주의하여 보드에서 떼어냅니다. 만약 부품이 잘 떨어지지 않으면 연결 부분을 칼로 절단 한 후 떼어 내면 쉽게 떼어 낼 수 있습니다. 본 제품은 접착제가 없이 조립이 가능하도록 설계되어 있습니다. 만약 축이 잘 끼워지지 않는 경우 양초를 축에 바른 후 끼워 보세요. 모든 구동 부위는 제품 구동 시 원활한 작동이 가능하도록 조립 과정에서 윤활제(양초)양초를 발라 주세요.

## FRA

Notice d'assemblage:  
Faites sortir de la planche les pièces comme indiquées sur le schéma. Tâchez de ne pas les casser. Si la pièce ne sort pas, incisez les collages/fixations avec un couteau. La construction est à assembler sans colle. Si il est difficile d'introduire l'axe en bois dans l'orifice, frottez au préalable l'axe ou les pièces contre une bougie. Pour améliorer le glissement, traitez les pièces de frottement mobiles du mécanisme avec une bougie au cours d'assemblage.

## CHI

装配说明  
将模型部件按插图示，从胶合板取下。小心不要损坏件。如果取下时候有难度，请用小刀小心的切割连接点。这个产品不需要胶水粘接。如果安装转轴的时候有难度，请用普通的蜡加以润滑。所有的转动部分也需要打蜡润滑。

## POL

Instrukcja montażu:  
Delikatnie wyciągaj z deseczki wskazane w schemacie detale, starając się nie połamać elementów. Jeśli detal nie poddaje się, podetnij wiązadła nożem. Konstrukcję składa się bez kleju. Jeśli napotkasz trudności z instalacją drewnianej osi w otwór, potrzyj na początku oś lub detale o woskową świecę. Dla lepszego poślizgu polecano smarowanie ruchomych części mechanizmu zwykłą świecą podczas montażu.

## SPA

Instrucciones de montaje:  
Saque de la tabla las piezas marcadas en el esquema. Trate de no romperlas. Si una pieza no se saca, haga una incisión. La construcción va sin pegamento. Si tiene dificultades con la instalación del eje de madera en un agujero, frote primero el eje o las piezas contra una vela. Para un mejor deslizamiento, lubrique durante el montaje las piezas móviles del mecanismo con una vela común.

## ITA

Istruzioni di montaggio:  
Estrarre dal telaio i particolari indicati nello schema. Fare attenzione a non romperli. Se un particolare non si stacca, tagliare delicatamente gli elementi di collegamento con un coltello. L'assieme viene realizzato senza colla. In caso di difficoltà nell'inserimento di un perno in legno, è necessario sfregare il perno o il particolare con un po' di cera. Per uno scorrimento migliore incerare le parti mobili del meccanismo durante l'assemblaggio.

ENG Warning! UKR Увага! DEU Achtung! FRA Attention! POL Uwaga! SPA Precaución! ITA Attenzione! TUR Dikkat! RUS Внимание! KOR 주의! CHI 注意!



ENG Do not use a lighted candle! UKR Не підпалювати! DEU Nicht anzünden! FRA Ne pas brûler! POL Nie podpalać! SPA ¡No encender! ITA Non dare fuoco! TUR Yakmayınız! RUS Не поджигать! KOR 불이 붙은 초를 이용하지 마세요! CHI 请勿点燃，请勿靠近火源！



ENG Caution! Axles have sharp points! UKR Обережно! Гострі деталі! DEU Vorsicht! Spitze Teile! FRA Attention: certaines pièces sont pointues! POL Ostrożnie! Ostre części! SPA ¡Atención! Piezas afiladas! ITA Attenzione! Particolari appuntiti! TUR Dikkat! Keskin parçalar! RUS Осторожно! Острые детали! KOR 축의 뾰족한 부분에 주의하세요! 注意! CHI 舍尖锐部件!



**ENG** Wax the part with a regular candle (rub with a candle). **UKR** Змастіть деталь звичайною свічкою (потріть об свічку).  
**DEU** Reiben Sie das Teil mit einer einfachen Kerze etwas ein. **FRA** Lubrifiez la pièce avec une bougie ordinaire (frottez contre la bougie).  
**POL** Przesmaruj zwykłą świecą. **SPA** Engrase la pieza con una vela común (frote con una vela). **ITA** Incerare il componente (sfregare con la cera). **TUR** Parçaya sade mum sürünüz. **RUS** Смажьте деталь обычной свечной (потрите о свечку).  
**KOR** 표시된 부분에 윤활을 위해 촛물 칠해 주세요. **CHI** 用普通蠟燭塗抹潤滑部件



**ENG** Break off or cut out. **UKR** Відламайте або відріжте. **DEU** Abbrechen oder Abschneiden. **FRA** Coupez ou cassez.  
**POL** Odłam lub odetnij. **SPA** Rompe o corte. **ITA** Staccare o tagliare. **TUR** Kırm veya kesin. **RUS** Отломайте или отрежьте.  
**KOR** 잘라내 주세요. **CHI** 切断



**ENG** Pay attention. Check for correct orientation or positioning. **UKR** Зверніть увагу. Перевірте розташування елемента.  
**DEU** Bitte Beachten. Prüfen Sie die Einbaulage des Elementes. **FRA** Faites attention. Vérifiez la disposition de l'élément.  
**POL** Zwróć uwagę. Sprawdź lokalizację elementu. **SPA** Atención. Compruebe la situación del elemento. **ITA** Prestare attenzione.  
Controllare la posizione del componente. **TUR** Dikkat. Elemanın yerleşimini kontrol ediniz. **RUS** Обратите внимание. Проверьте расположение элемента. **KOR** 방향 또는 위치에 주의해서 조립해 주세요. **CHI** 注意！检查部件方向和位置



**ENG** Check the mechanism for smooth and correct movement. Operate the mechanism to seat the parts in their positions.  
**UKR** Перевірте механізм на плавність і точність ходу. Розробіть механізм. **DEU** Prüfen sie den Mechanismus bezüglich der Laufruhe und der Genauigkeit des Ganges. Arbeiten Sie den Mechanismus aus. **FRA** Vérifiez si le mécanisme fonctionne en douceur et avec précision. Faites fonctionner le mécanisme jusqu'à son fonctionnement normal. **POL** Sprawdź płynność i dokładność ruchu mechanizmu. Dopracuj mechanizm. **SPA** Verifique la suavidad y precisión del mecanismo. Desarrolle el mecanismo. **ITA** Controllare la scorrevolezza e la precisione del movimento. Far funzionare il meccanismo. **TUR** Mekanizmanın sarsılmadan düzgün bir şekilde çalışmasını kontrol ediniz. Mekanizmayı hazırlayıp çalıştırınız. **RUS** Проверьте механизм на плавность и точность хода. Разработайте механизм. **KOR** 구동 부분의 원활한 작동과 정확한 움직임을 확인하세요. **CHI** 检查机构的运行平稳度和精密度。调试机构



**ENG** Perform the same steps in mirror image. **UKR** Здійснити аналогічне складання у дзеркальному відображенні.  
**DEU** Den analogen Zusammenbau in der Spiegelreflexion zu machen. **FRA** Procédez à l'assemblage dans le sens opposé (inverse).  
**POL** Dokonaj analogiczny montaż w odbiciu lustrzanym. **SPA** Haga un ensamblaje similar en imagen especular. **ITA** Realizzare lo stesso assemblaggio nell'immagine speculare. **TUR** Aynı yansımasında aynı montaj yapınız. **RUS** Произвести аналогичную сборку в зеркальном отражении. **KOR** 동일한 부분을 대칭이 되도록 쌍으로 작업해 주세요. **CHI** 在镜面对称执行相同的步骤



**ENG** Sand to remove burrs. **UKR** Видалить задирки. **DEU** Grate entfernen. **FRA** Éliminez les bavures. **POL** Usuń zadziory. **SPA** Quite las rebabas. **ITA** Togliere le bave. **TUR** Çapakları çıkartınız. **RUS** Удалите заусенцы. **KOR** 거친 부분을 다듬어 주세요. **CHI** 磨掉毛刺



**ENG** Spare parts. **UKR** Запасні деталі. **DEU** Ersatzteile.  
**FRA** Pièces de rechange. **POL** Części zamiennie. **SPA** Piezas de repuesto.  
**ITA** Pezzi di ricambio. **TUR** Yedek parçalar. **RUS** Запасные детали.  
**KOR** 여유 부품입니다. **CHI** 备用件

**ENG** This is not a structural component; it is a tool for measurement and assembly. **UKR** Це не деталь конструкції, а допоміжний інструмент для складання або вимірювання відстаней. **DEU** Es ist kein Teil der Konstruktion, sondern ein Hilfselement für den Zusammenbau oder für das Messen der Abstände. **FRA** Cette pièce ne fait pas partie de la construction mais constitue un outil annexe pour l'assemblage ou la mesure des distances. **POL** To nie detal konstrukcji, a pomocnicze narzędzie dla montażu i wymiaru odległości. **SPA** No es una pieza de la construcción sino un instrumento auxiliar para montar o para medir distancias. **ITA** Non è un componente del modello, ma un'attrezzatura aggiuntiva per il montaggio o il rilievo delle quote. **TUR** Yapı parçası değil. Kurulum yapmak veya mesafe ölçmek amacıyla kullanılan yardımcı aletlerdir. **RUS** Это не деталь конструкции, а вспомогательный инструмент для сборки или измерения расстояний. **KOR** 이 부품은 조립을 위한 부품이 아니고 조립을 돕거나 측정을 위한 도구입니다. **CHI** 这不是装配零部件，是一种测量及安装辅助工具。



**ENG** Axle. **UKR** Біль. **DEU** Achse. **FRA** Axe. **POL** Oś. **SPA** Eje. **ITA** Asse. **TUR** Eksen. **RUS** Ось. **KOR** 축. **CHI** 轴承





①

1

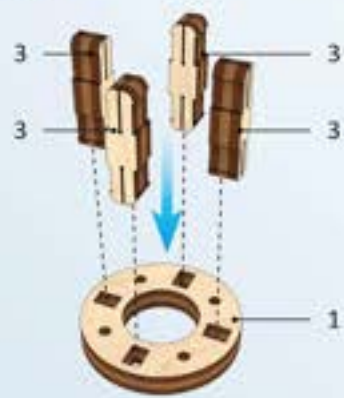

2

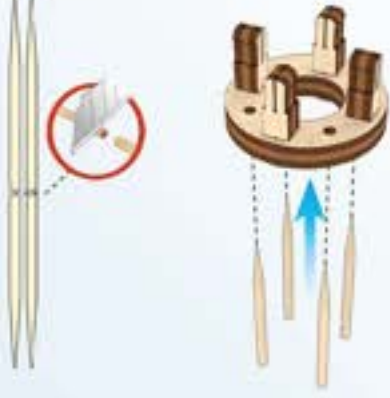

3



4

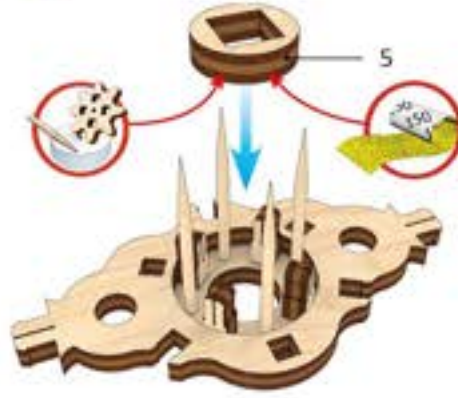

5



6



7



8



a1



④



1

2

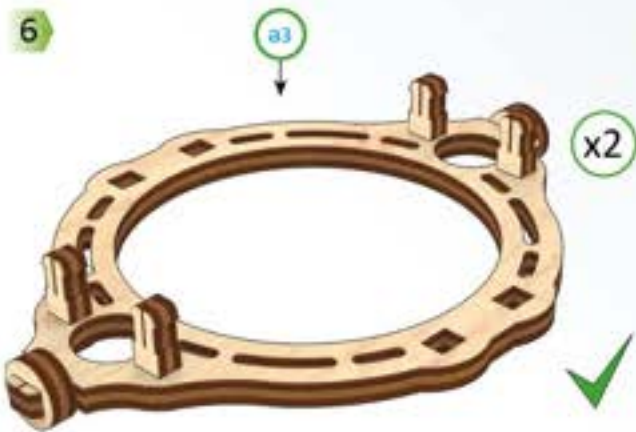
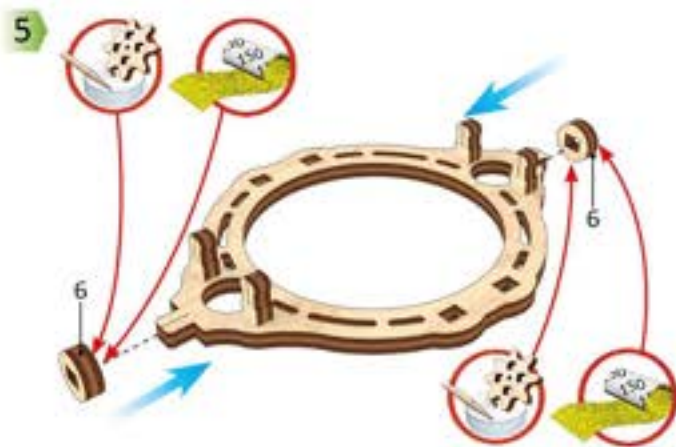
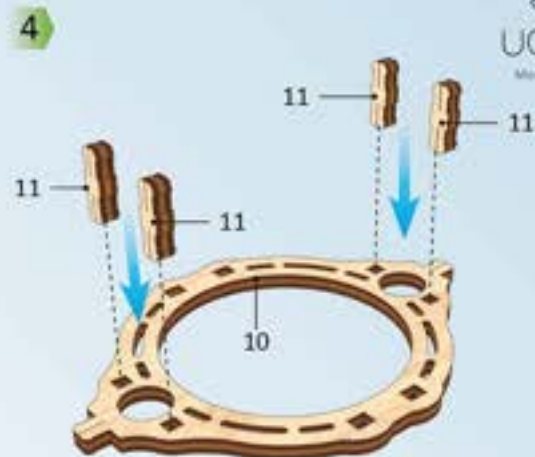
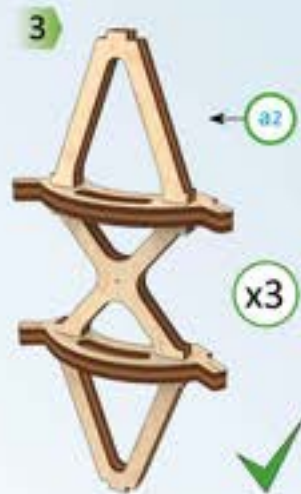
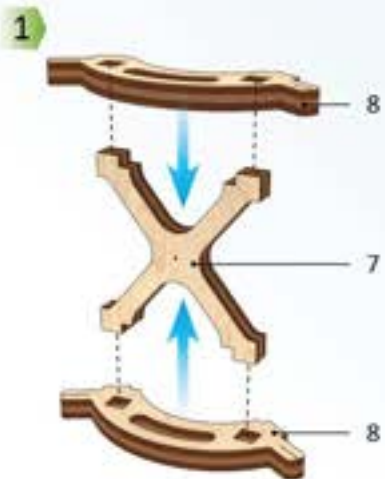



1

2

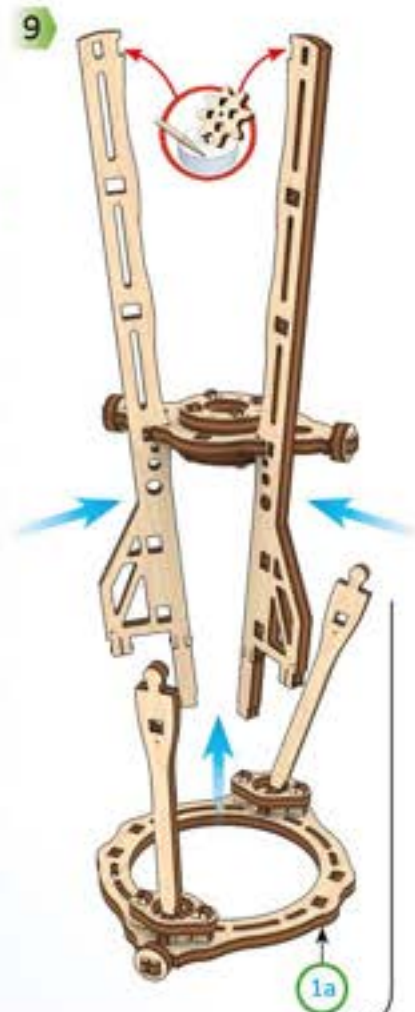
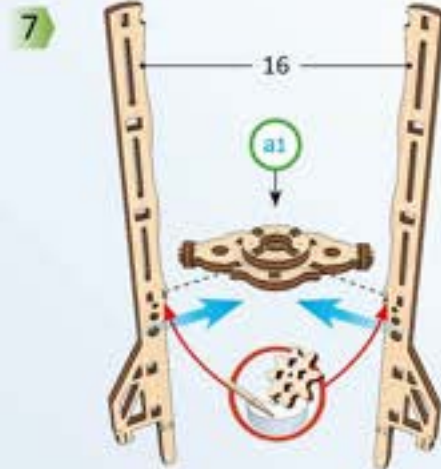
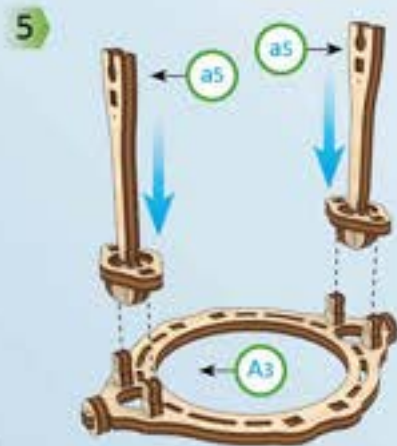
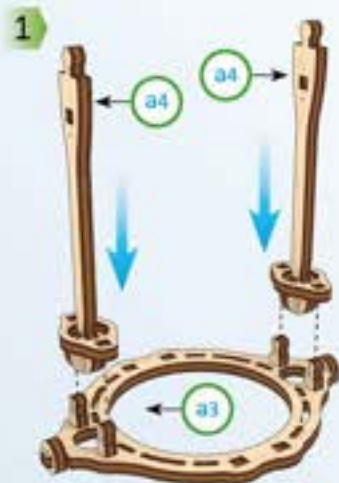

6

1



2

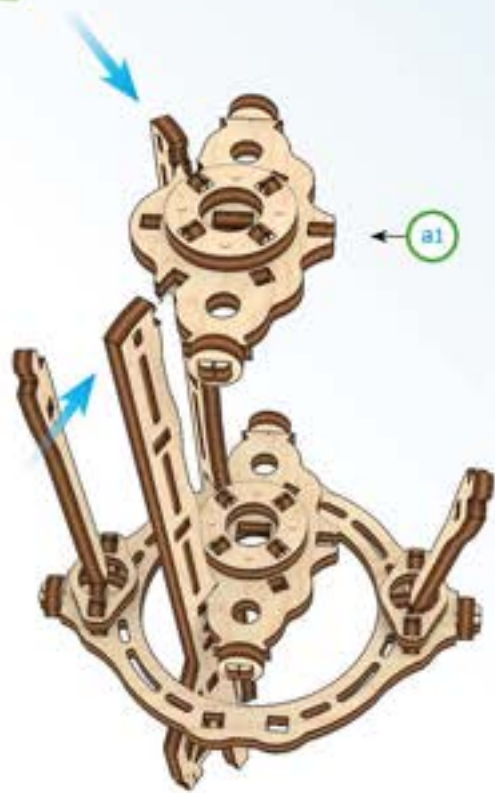

3

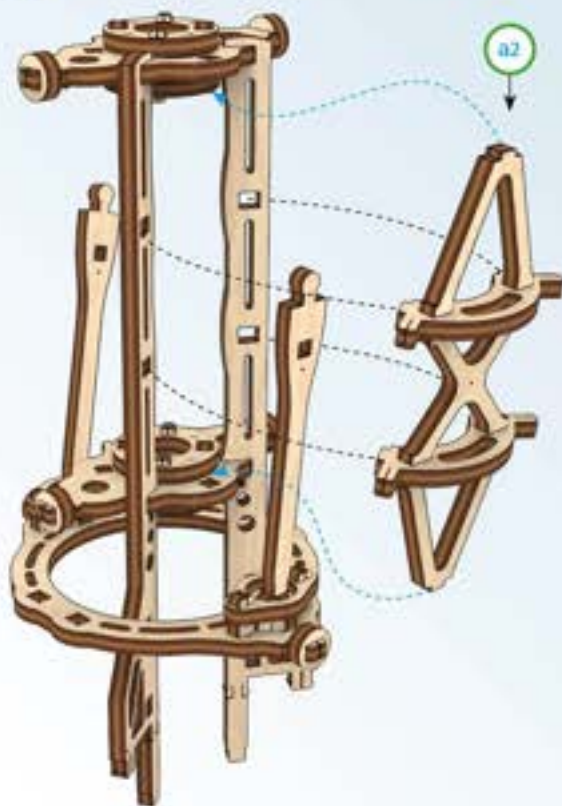

4

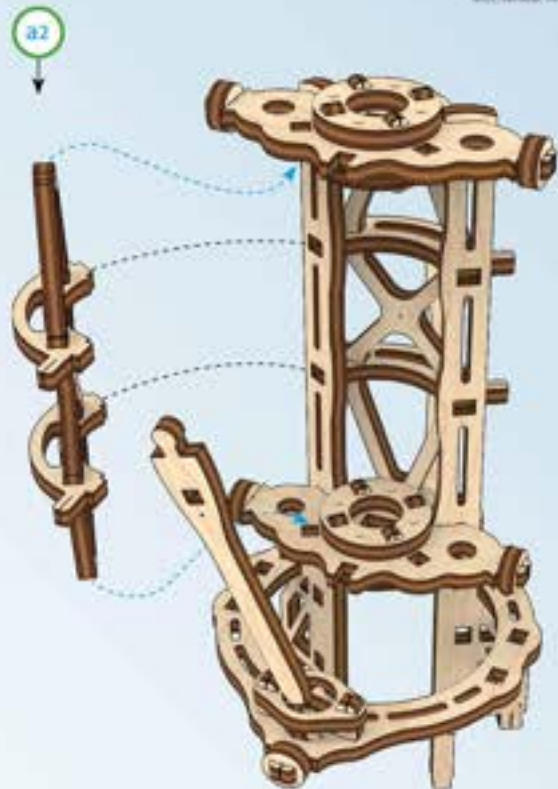



1

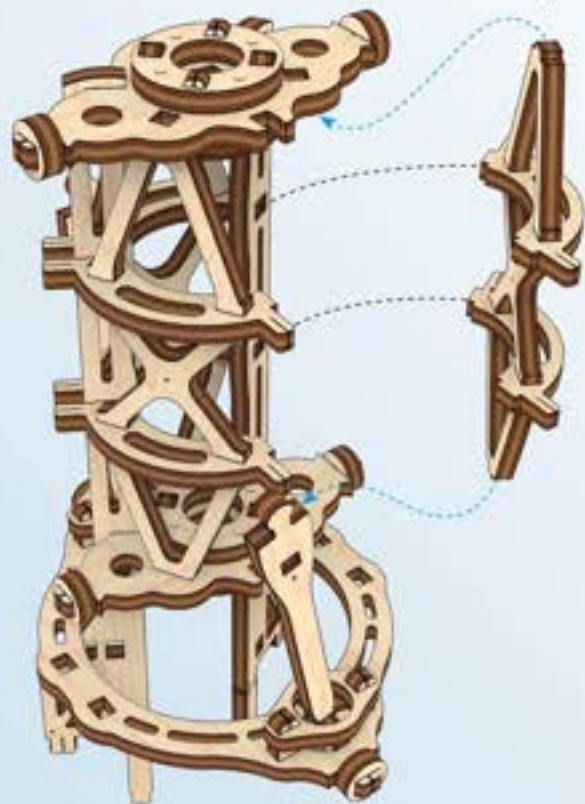

2



3

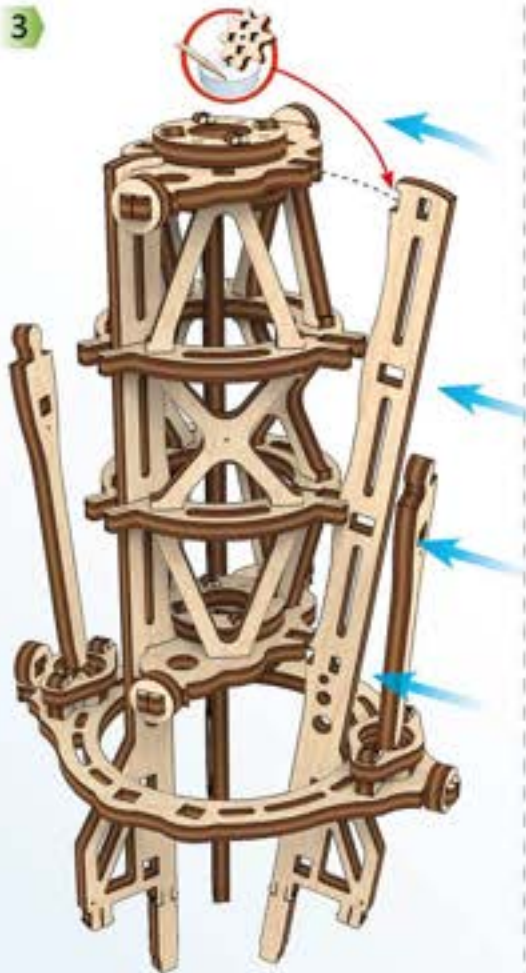

4





1



2

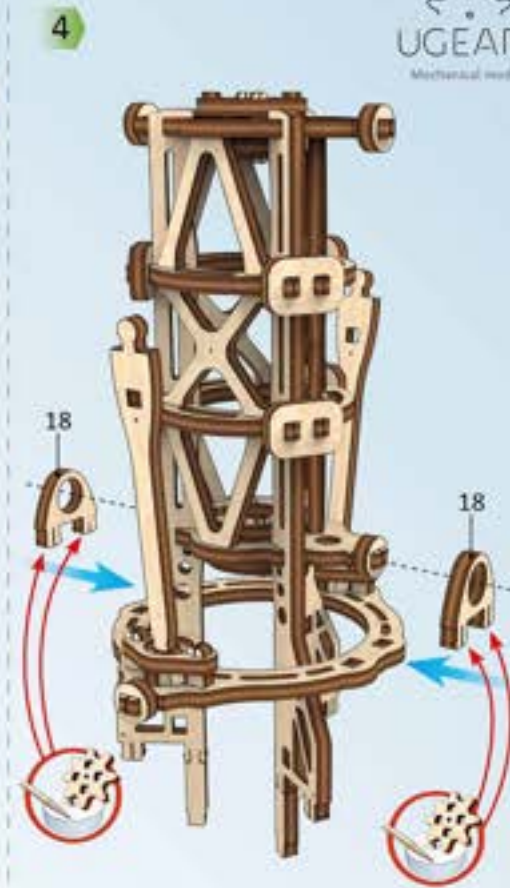
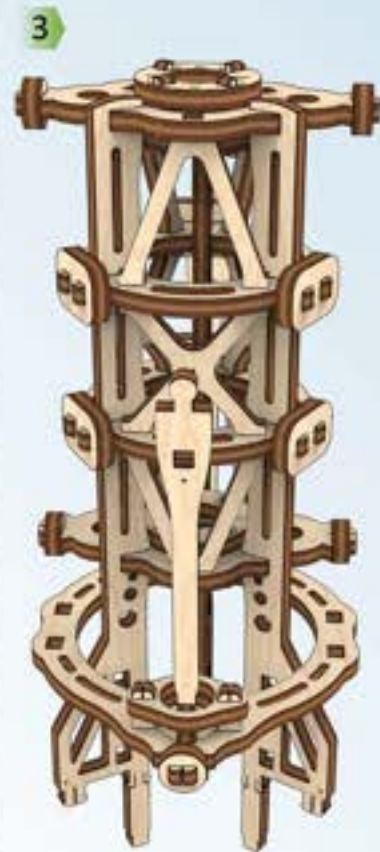
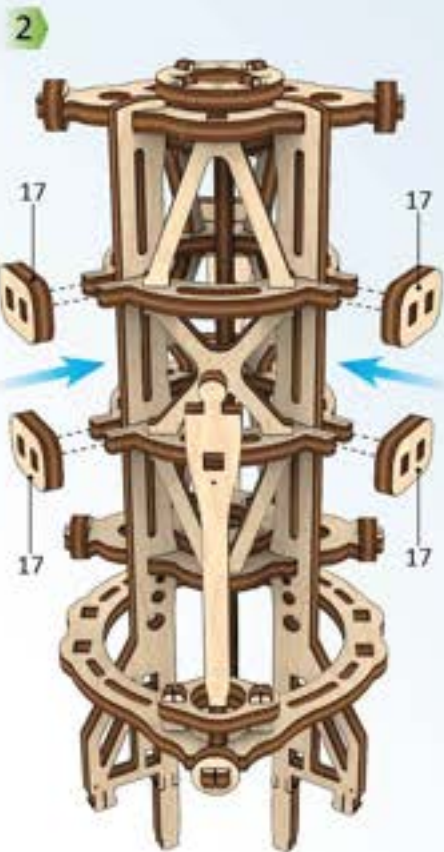
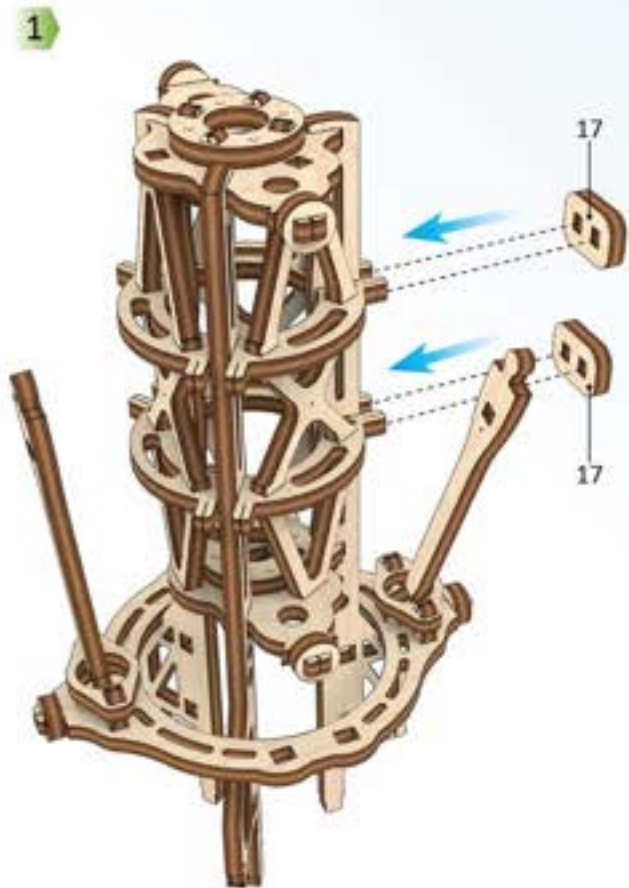



3

1



2



3

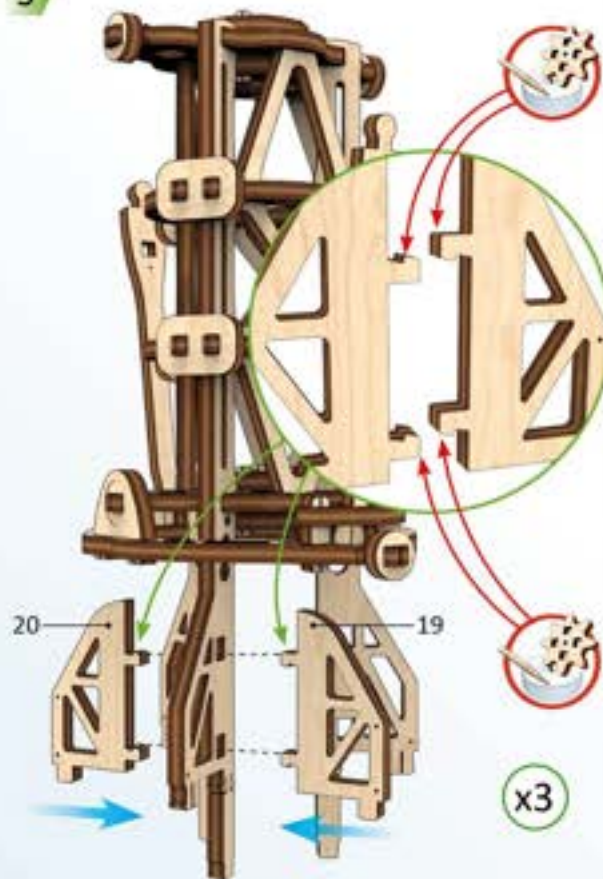

4

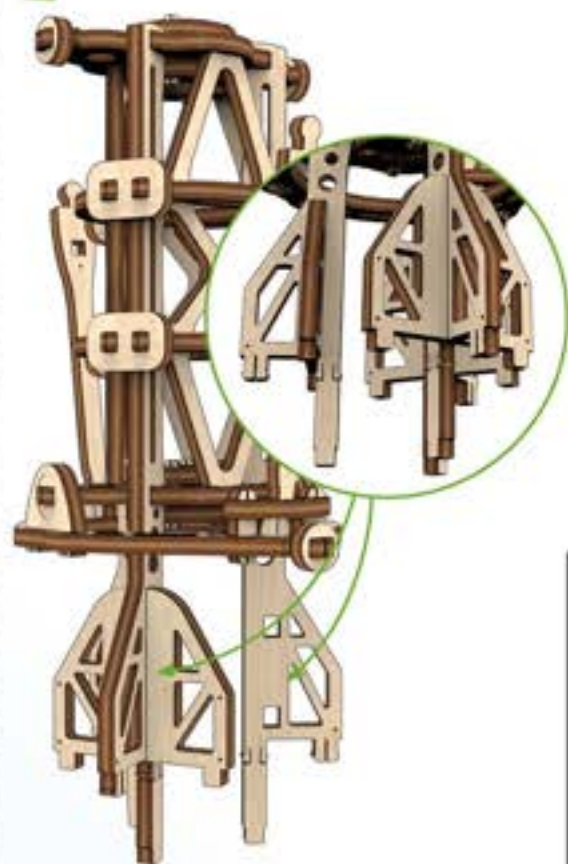



①

1

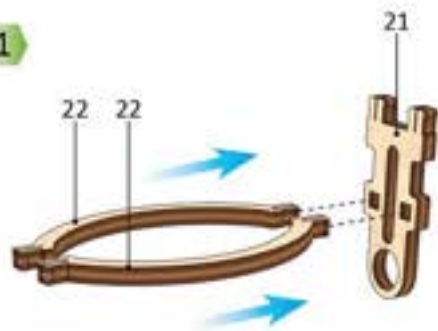

2



3

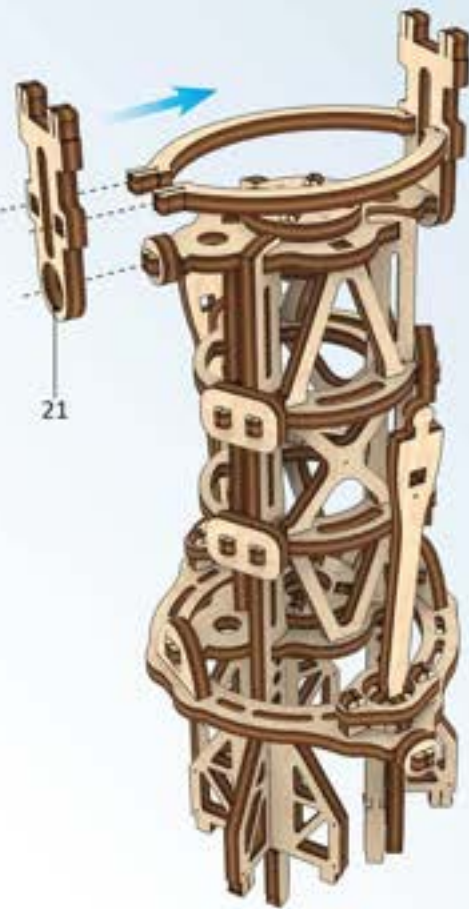

4





1



2



3

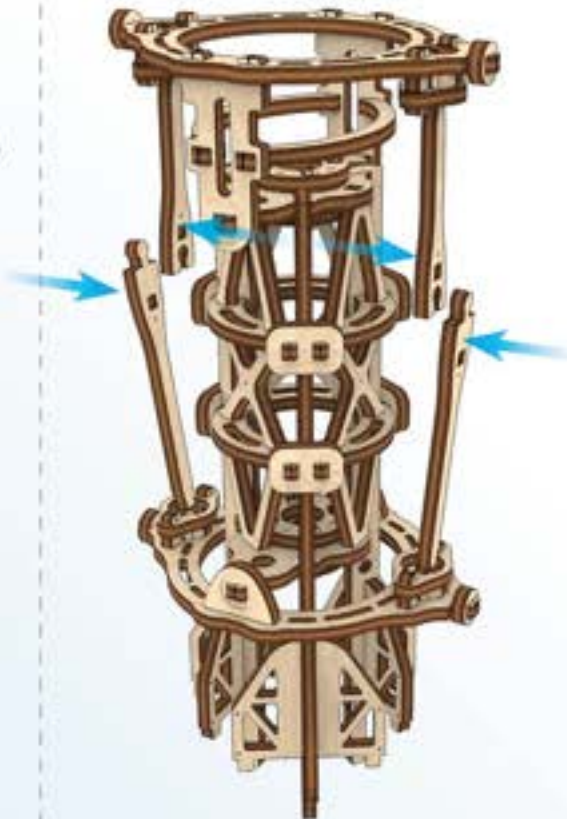

4

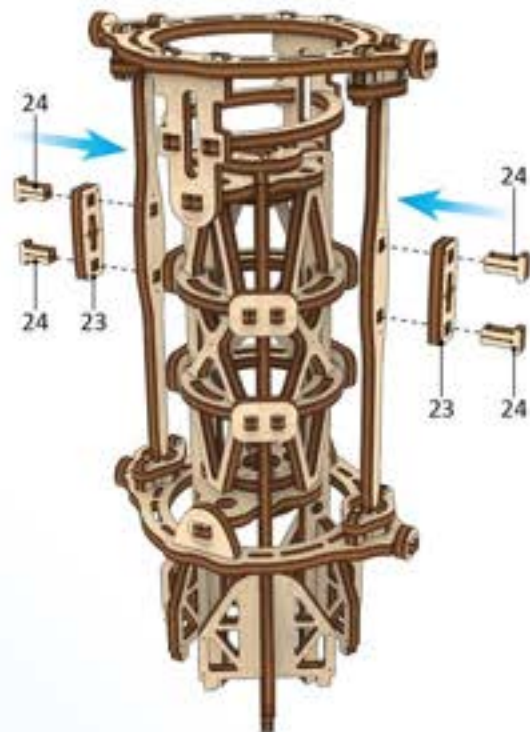



2

1



2

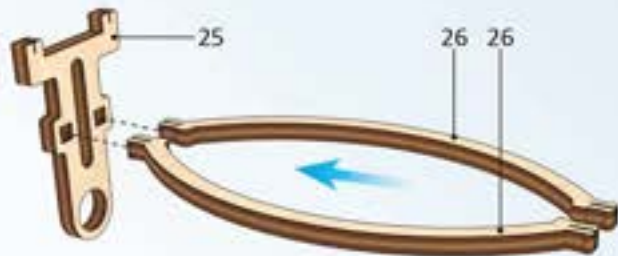

3

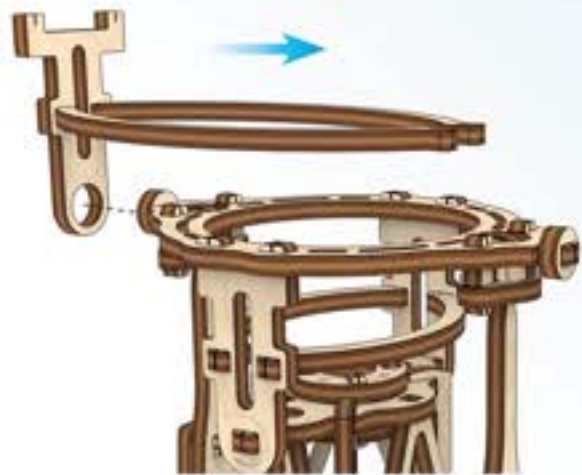

4

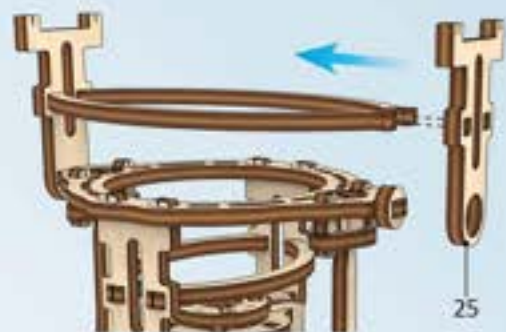



4

5

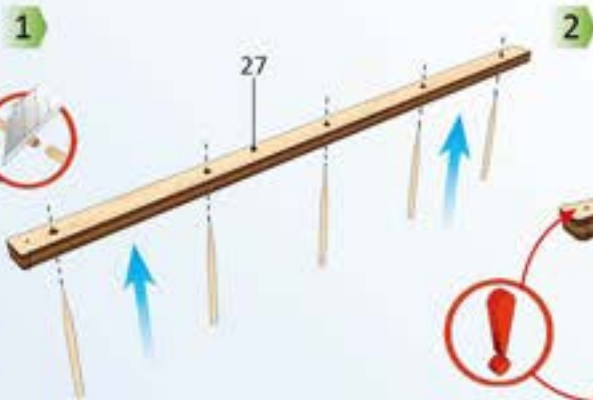

2

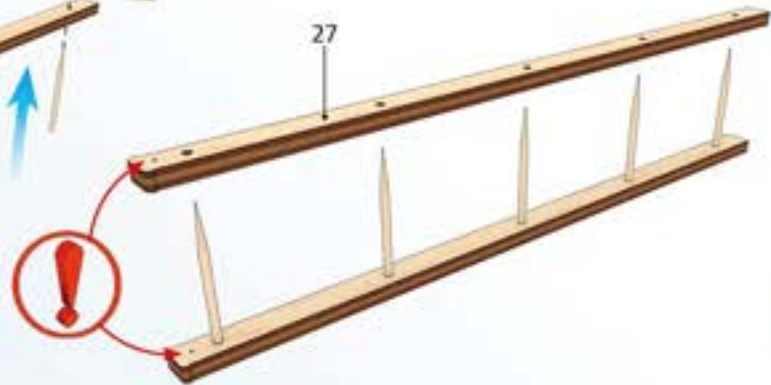

3

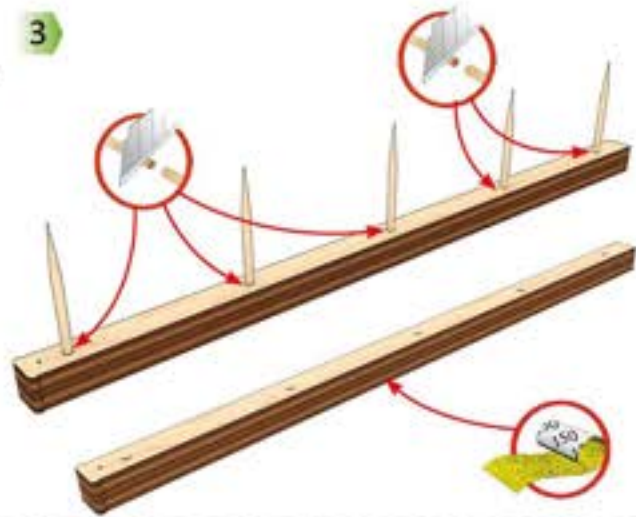

4

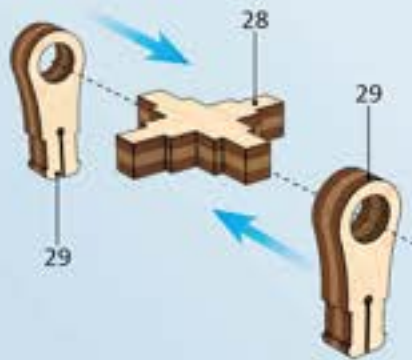

5



6



7



8

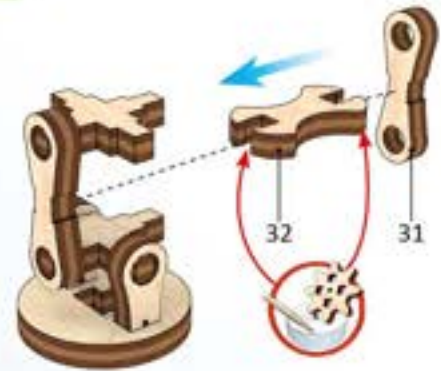



4



5

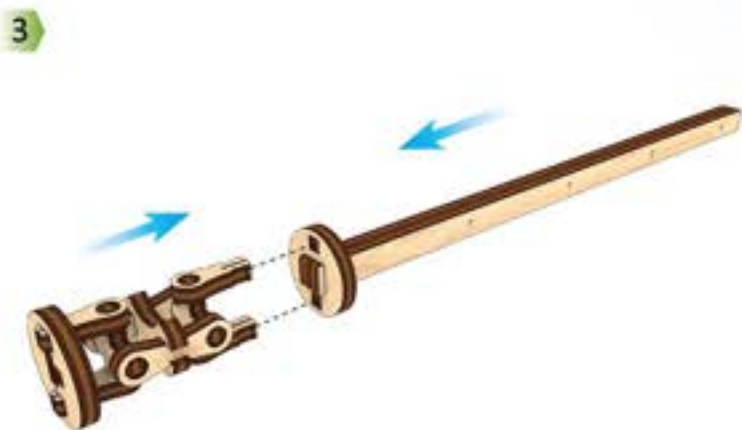
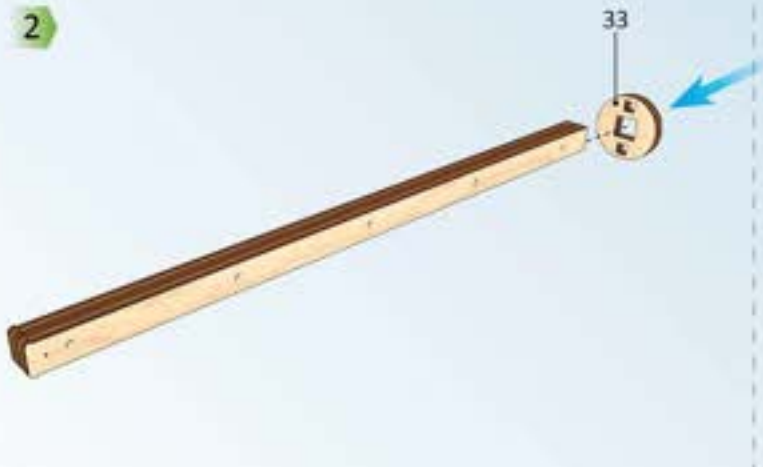
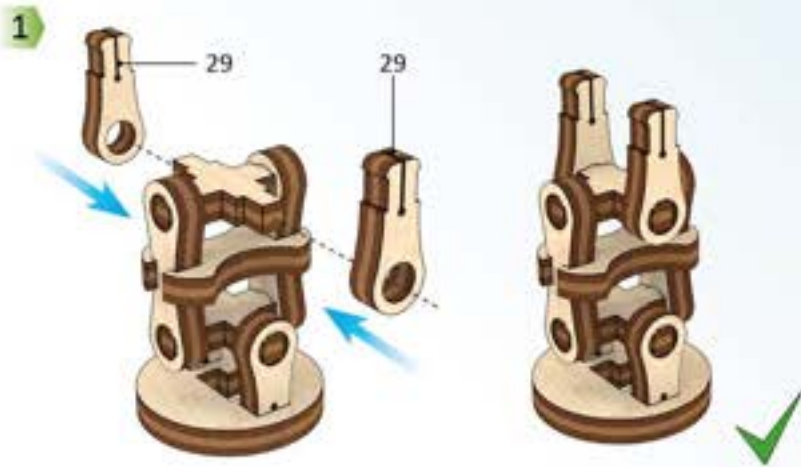

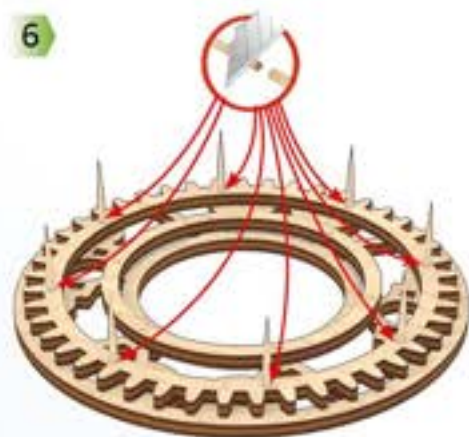
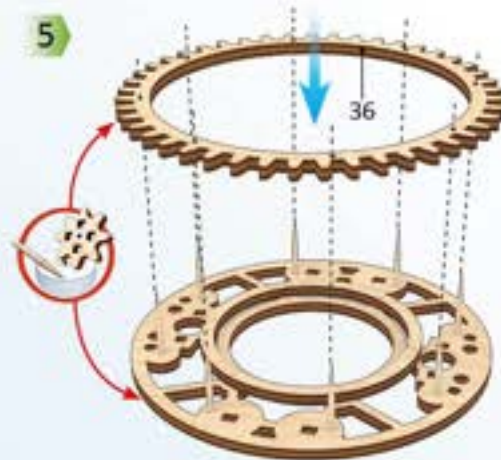
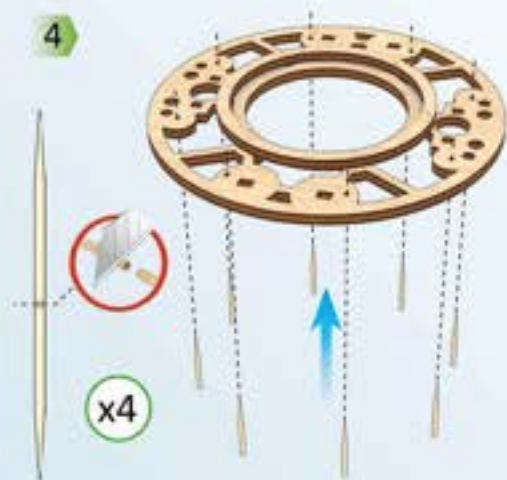
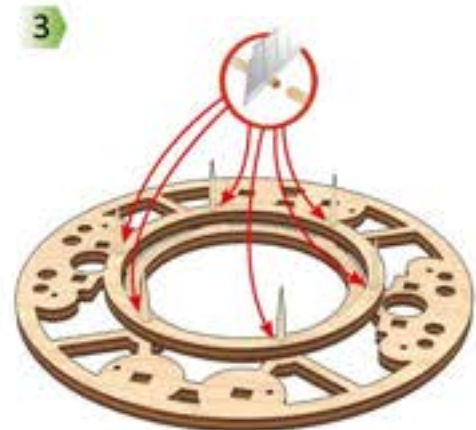
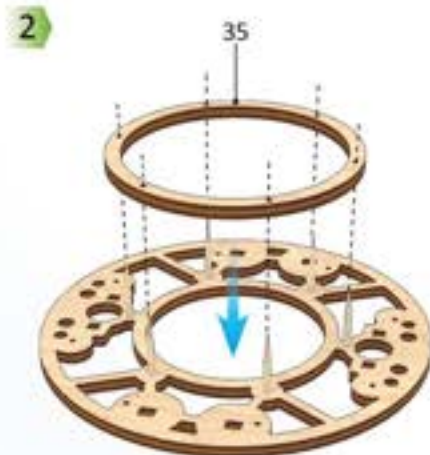
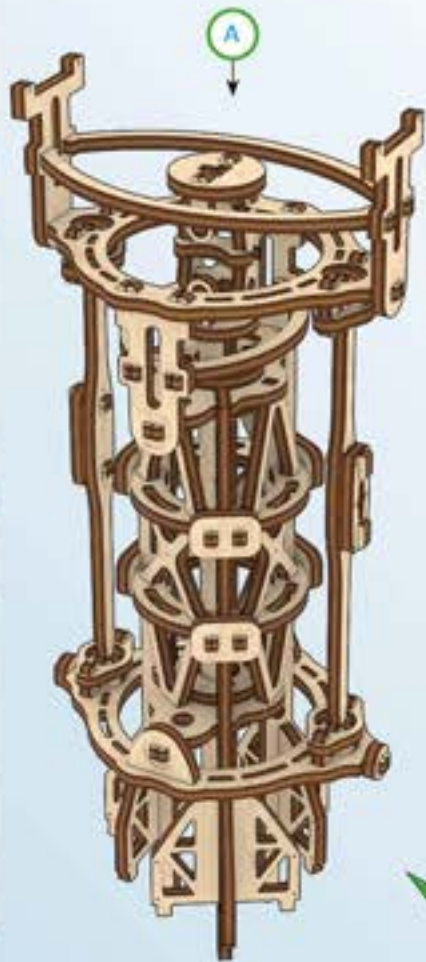



①

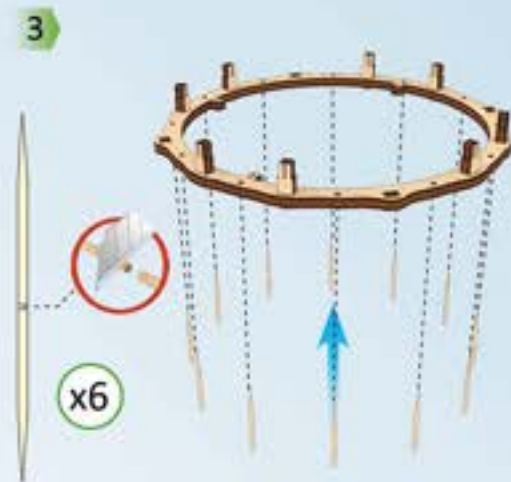
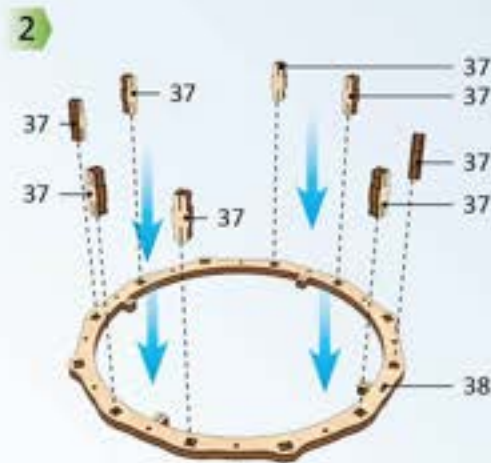

②

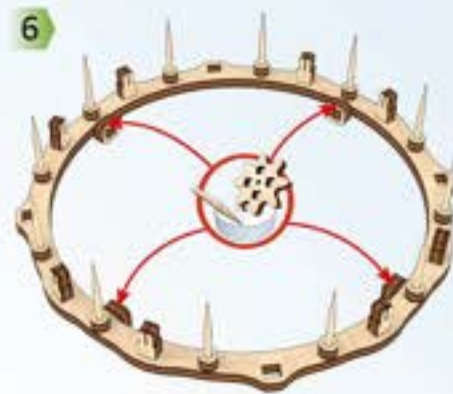
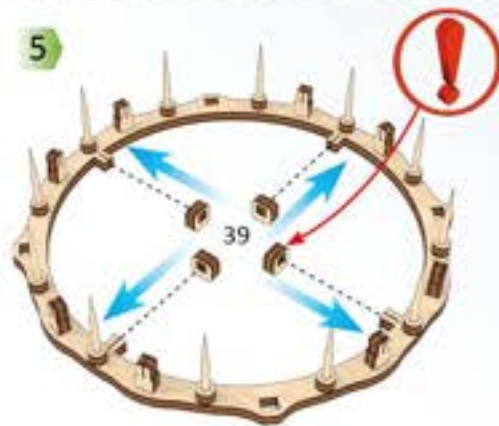
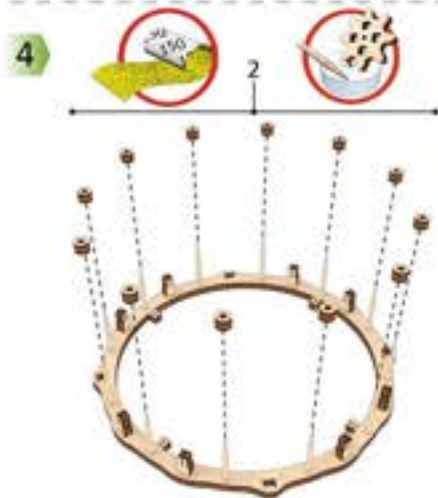



2

3



1

40

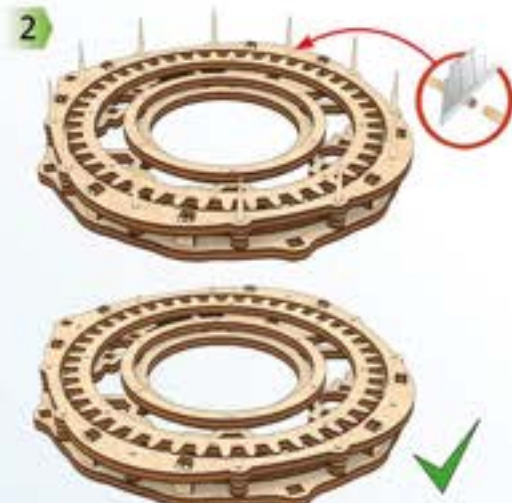

2

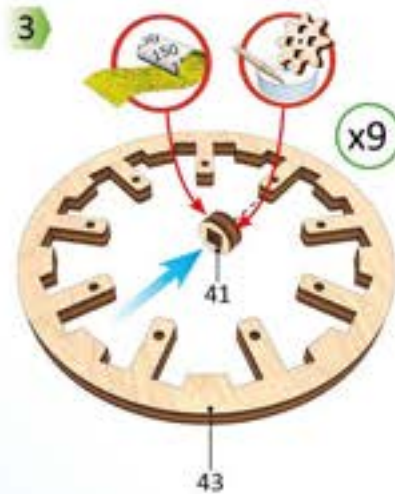

3

41

x9

43



4

42

x9



5

x5



6

44



7



8



1

2

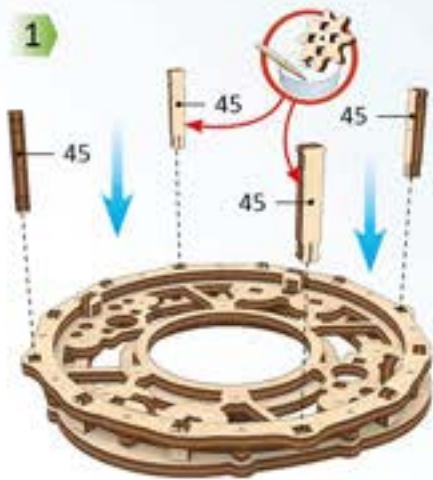

2



3



4



5

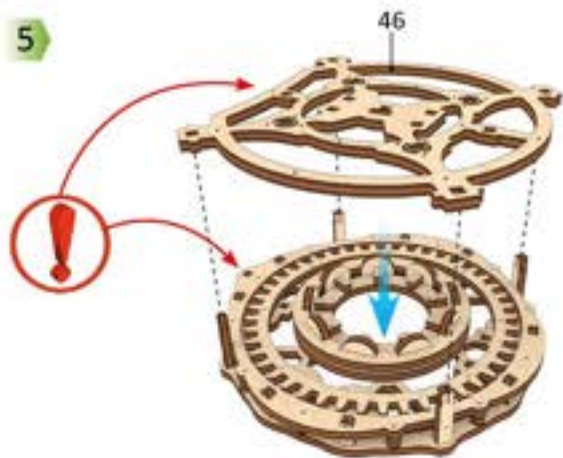

6



7



8



b1





4

5

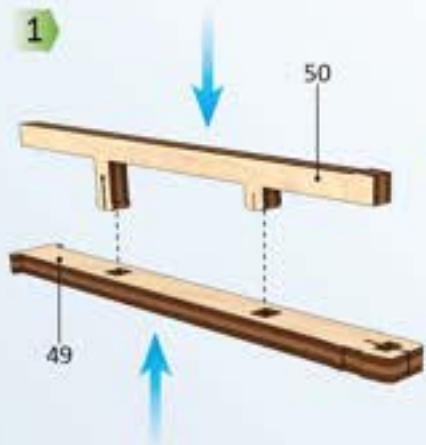

1

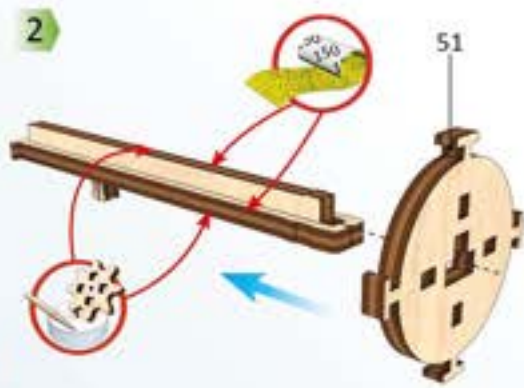

2

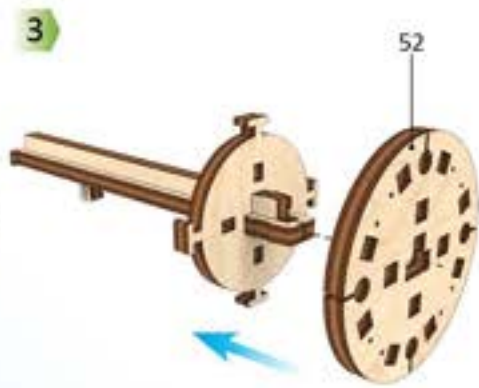

3

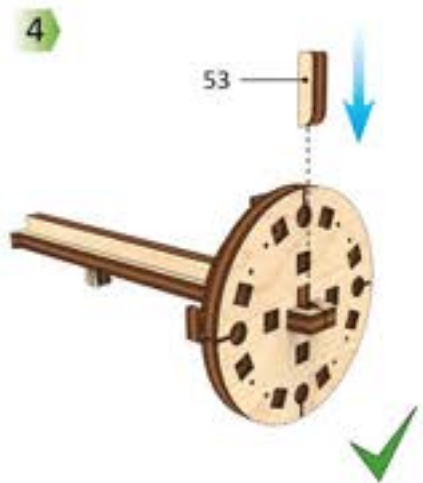

4



5

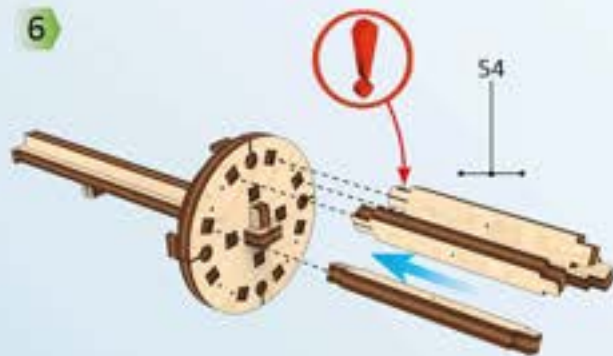

6

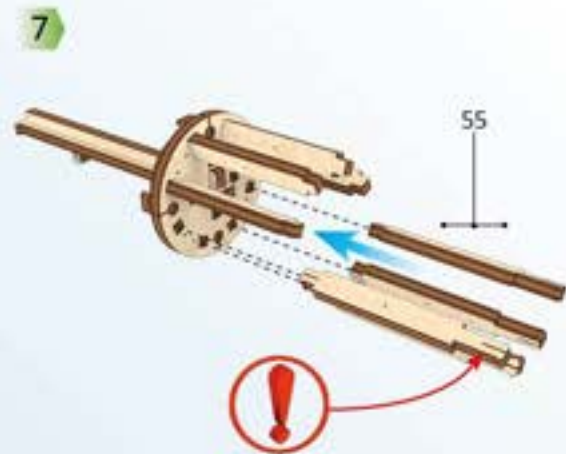

7

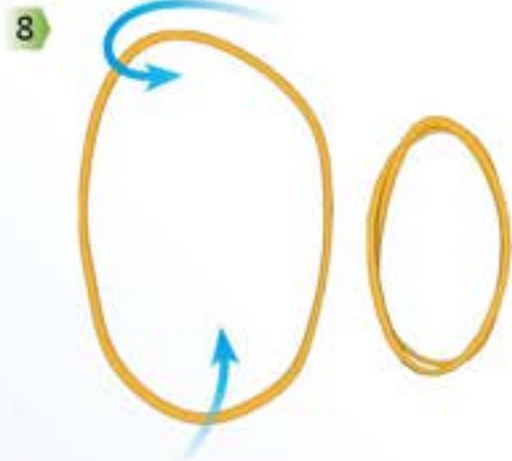

8

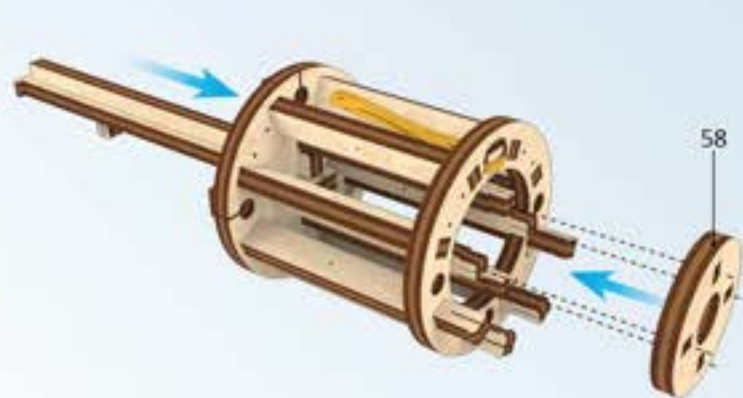
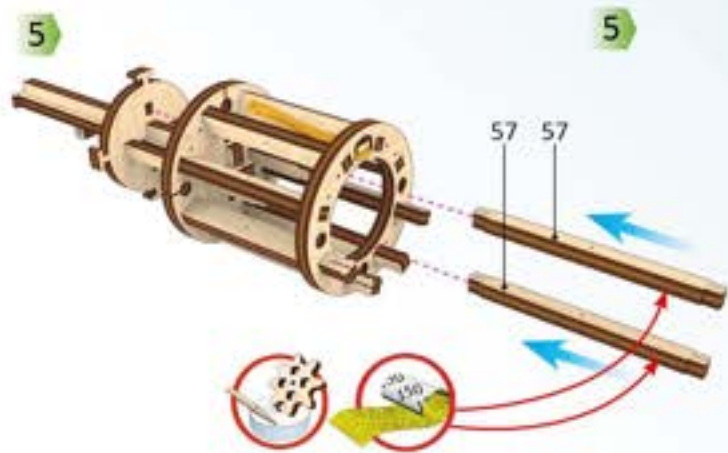
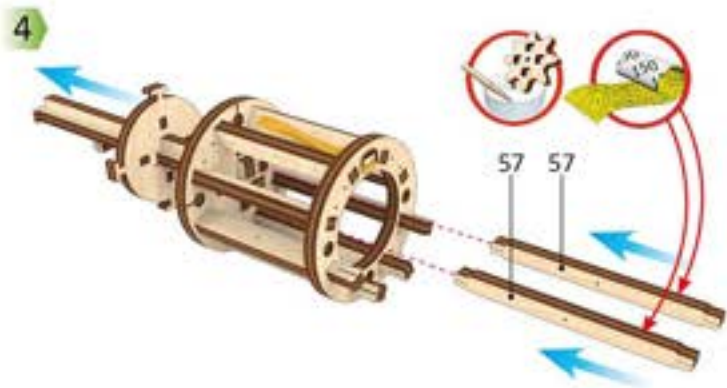
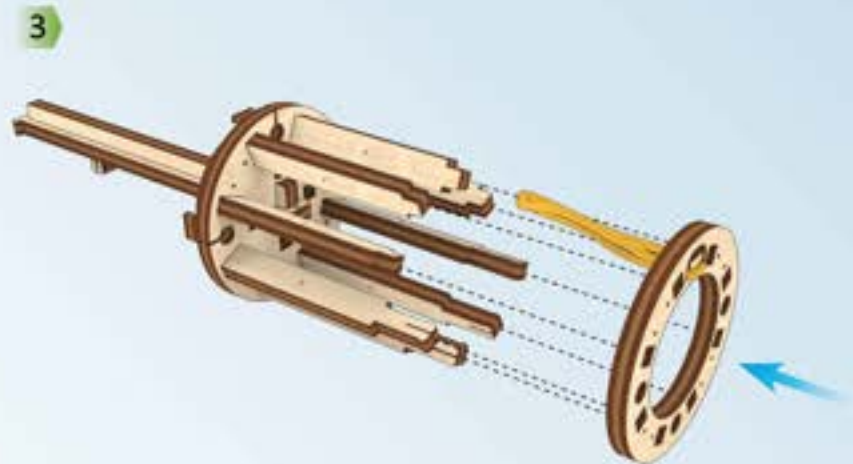
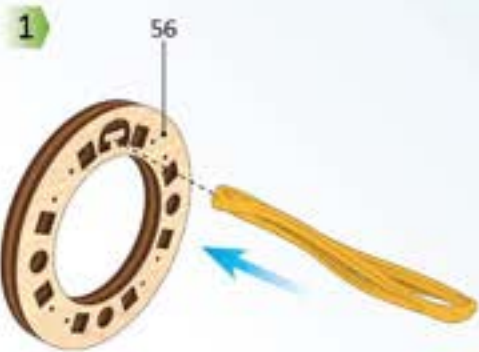



4

1

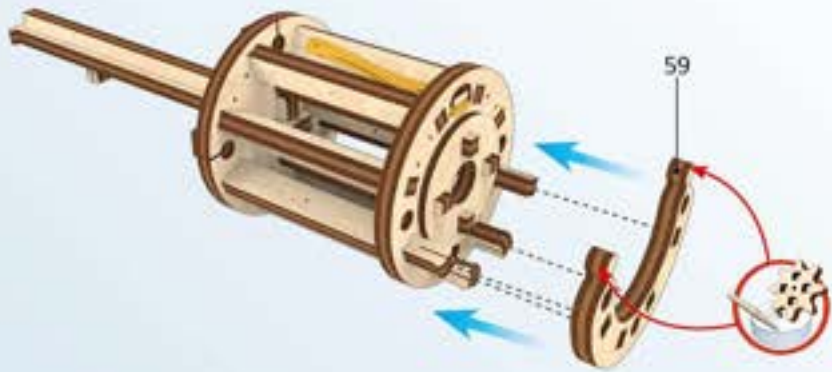

2



3



4



5



6



7



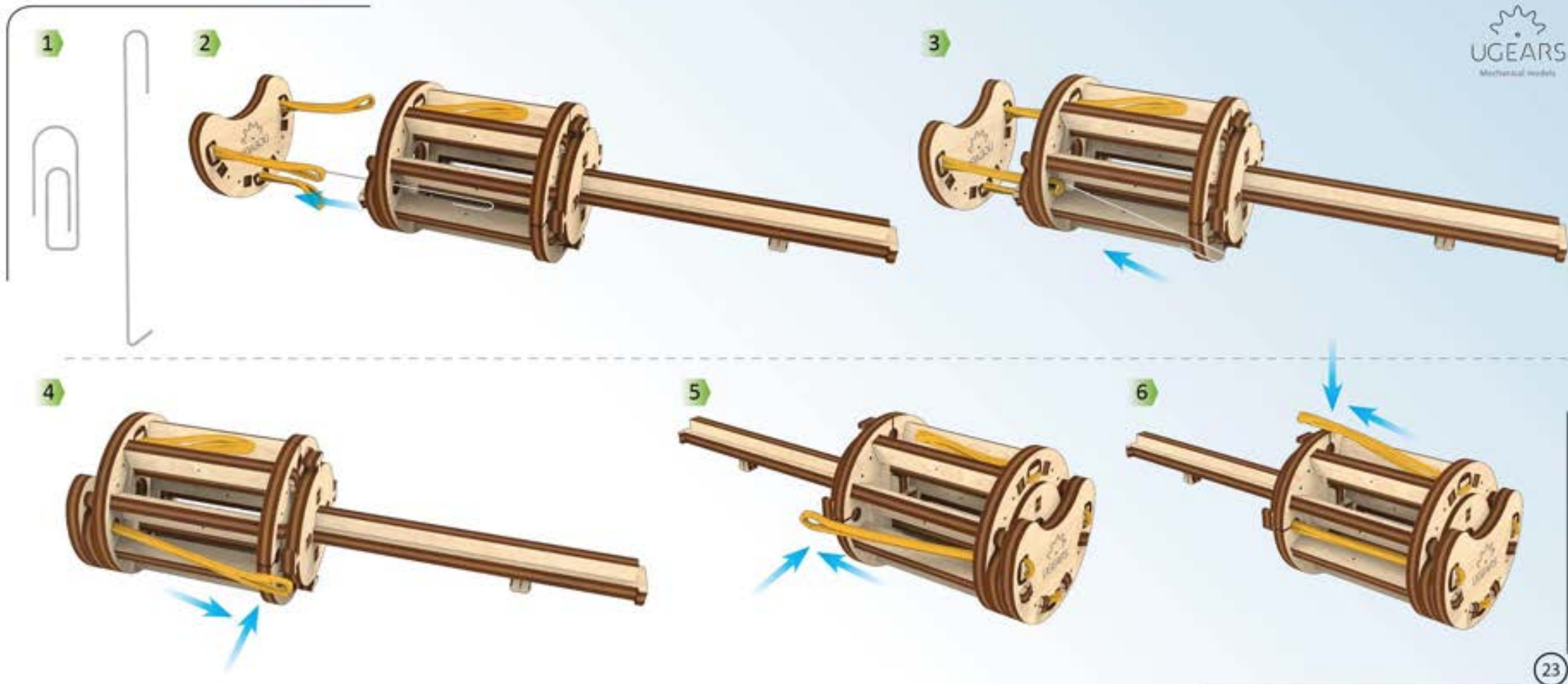



2



4



8

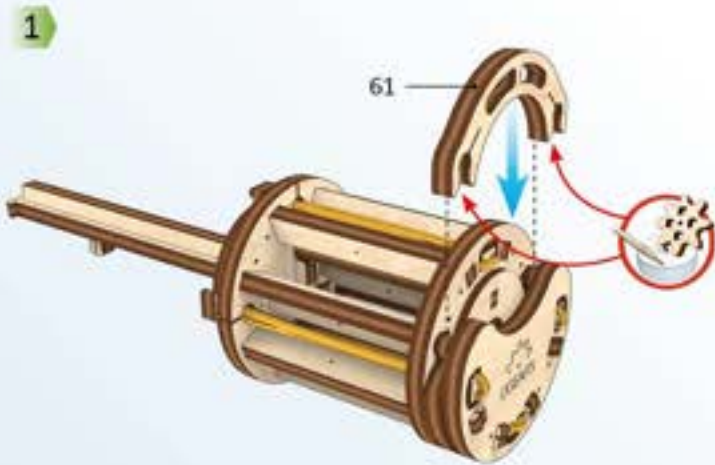

1

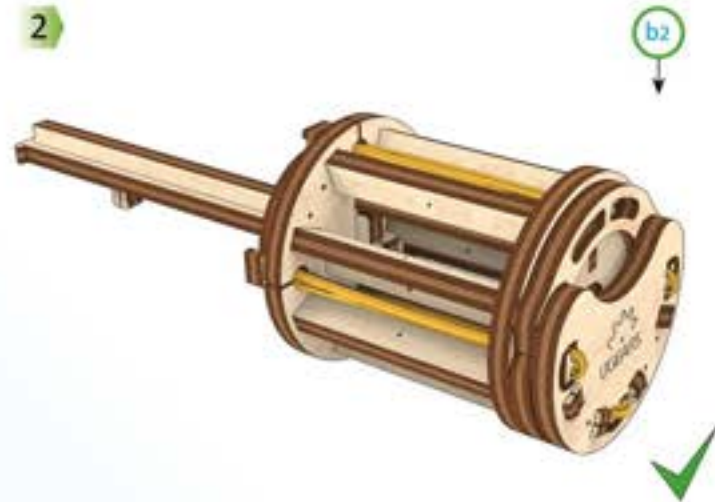

2

b2

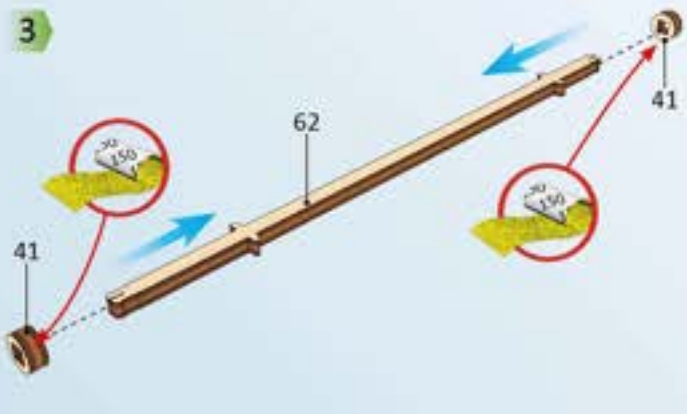

3

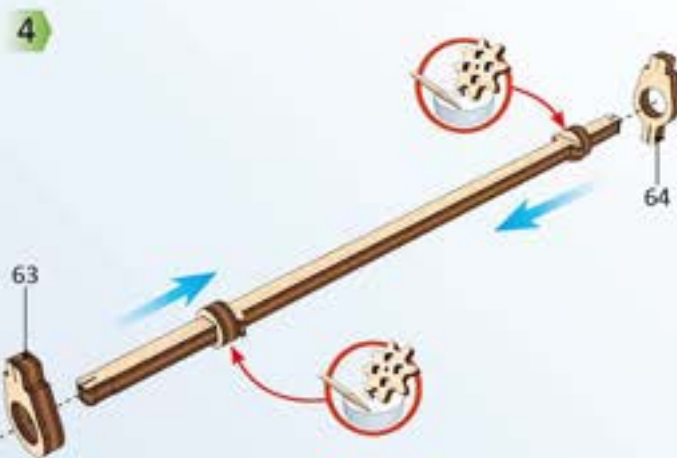

4



5

66

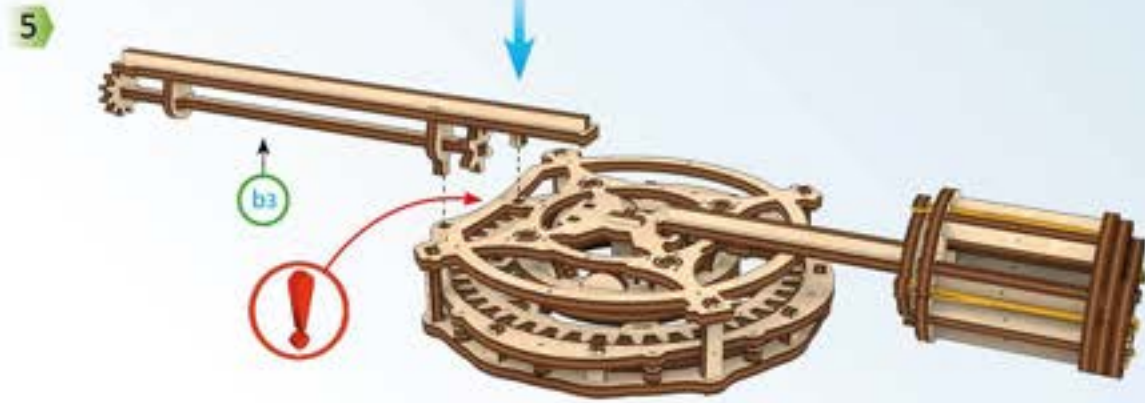
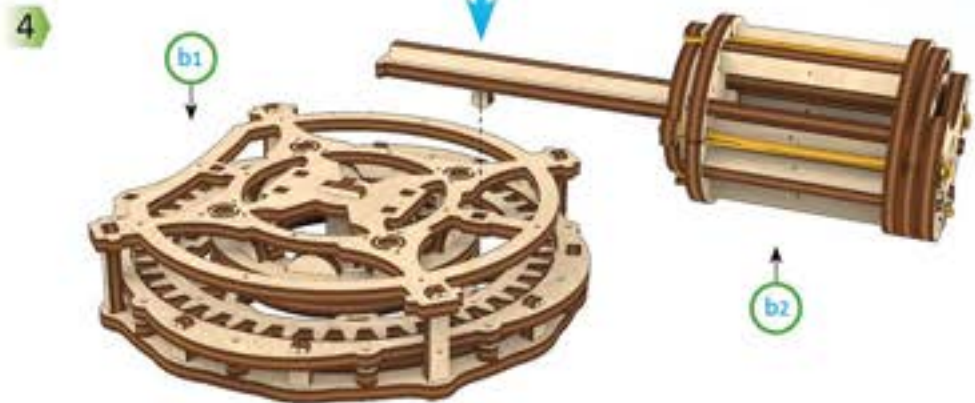
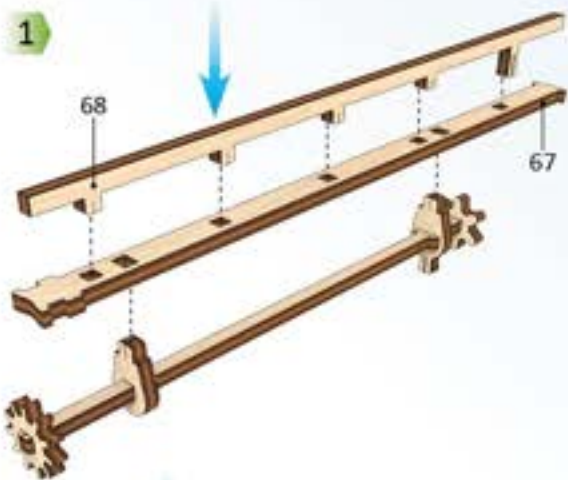



2

3

1

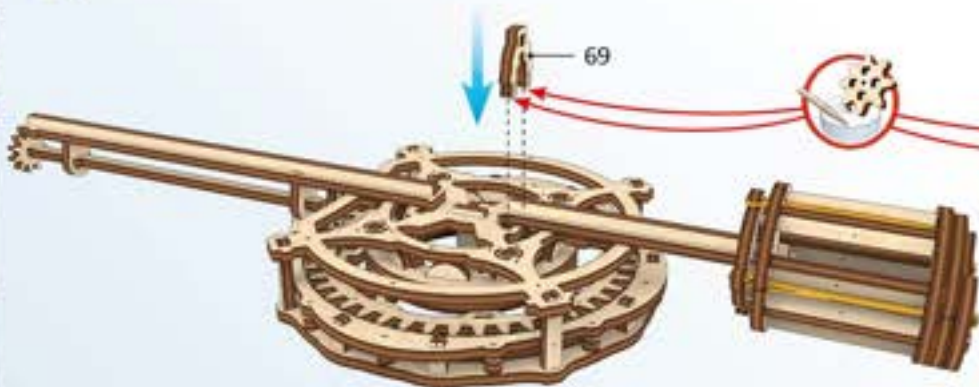

2

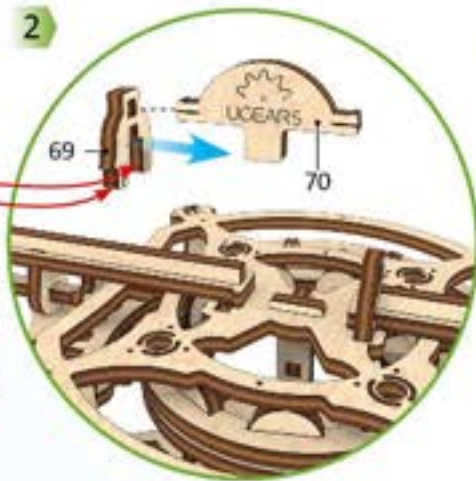

3

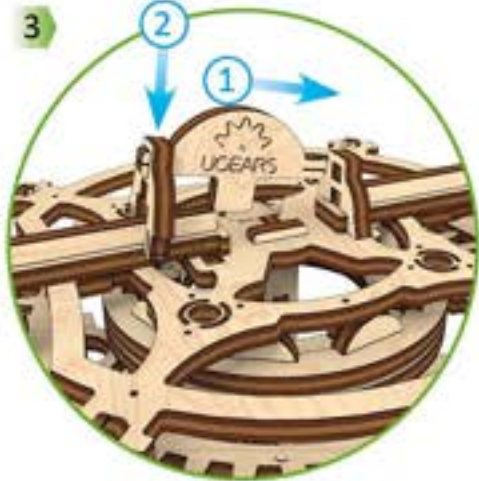

4



5

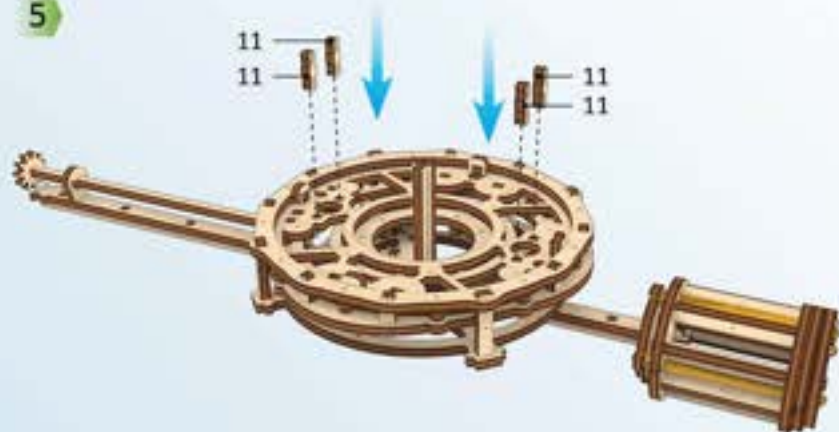





1

2

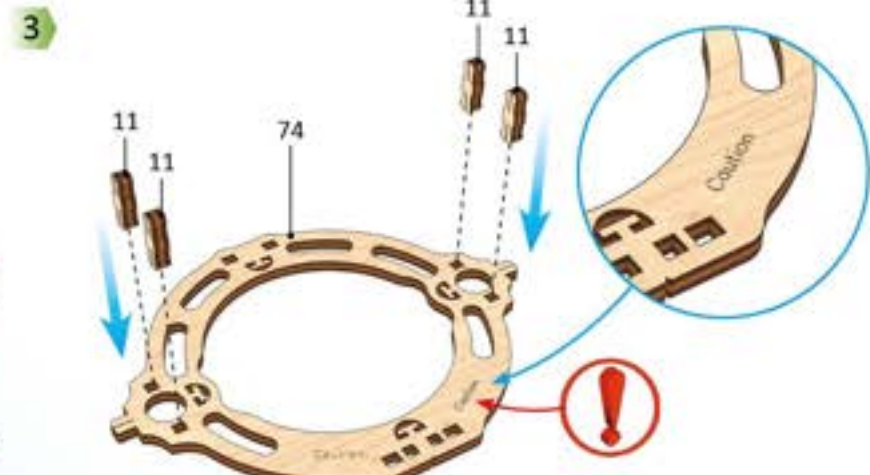
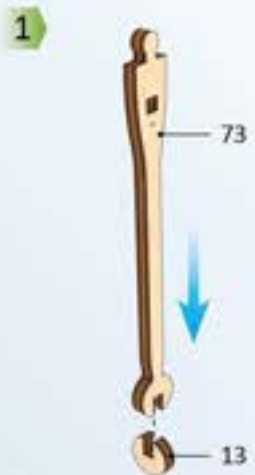

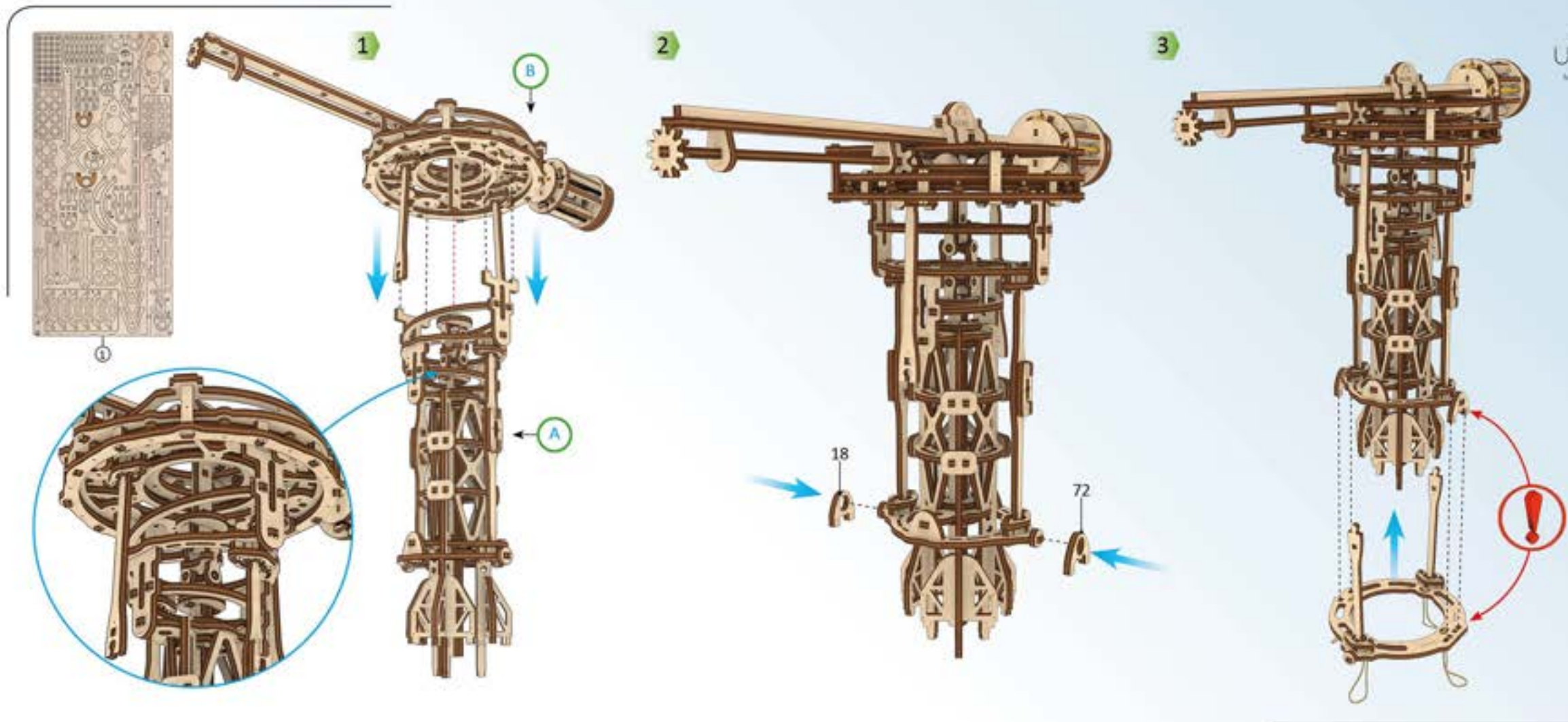



1

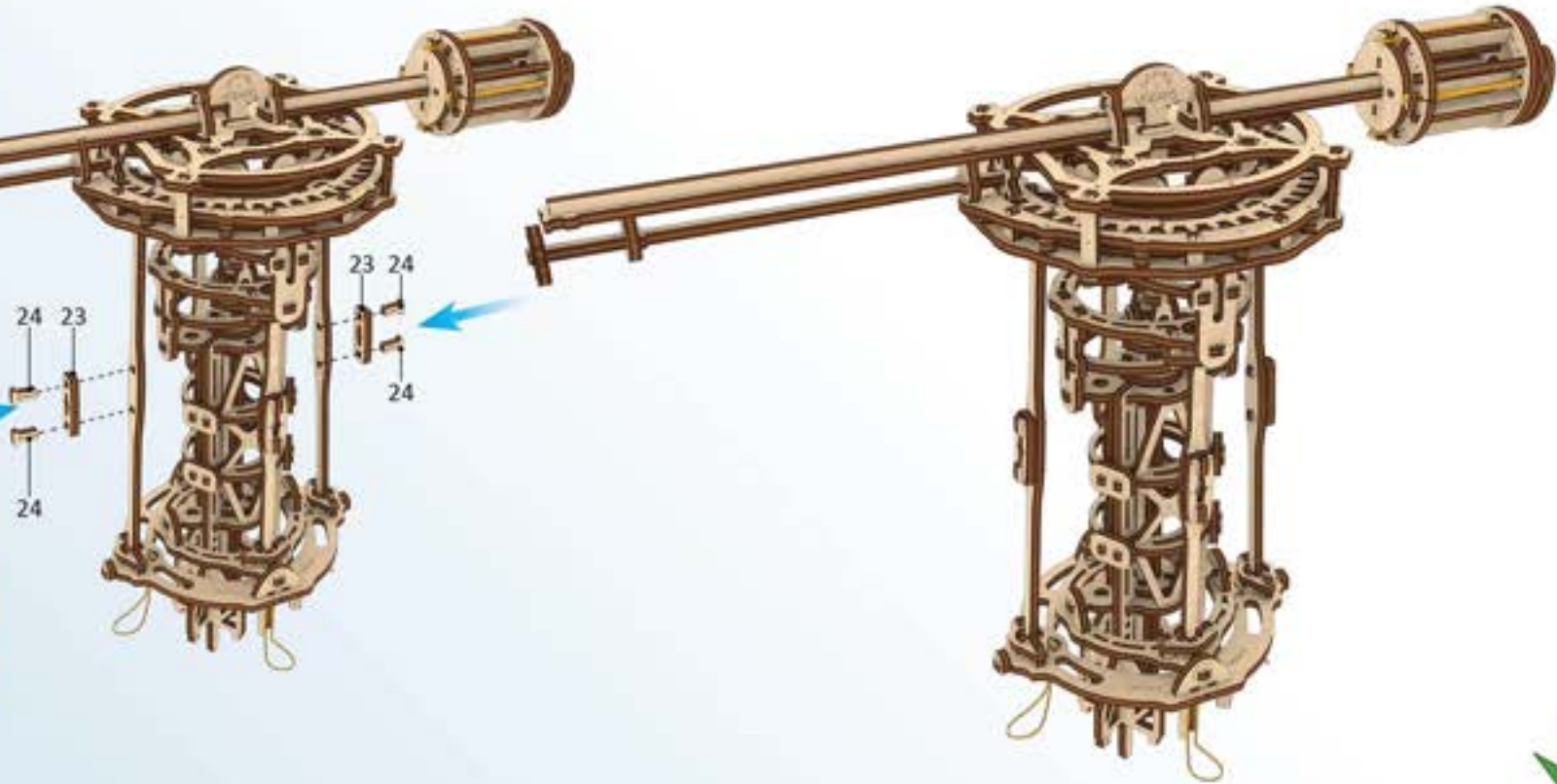



1

2

1

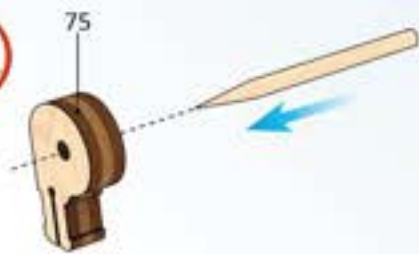

2

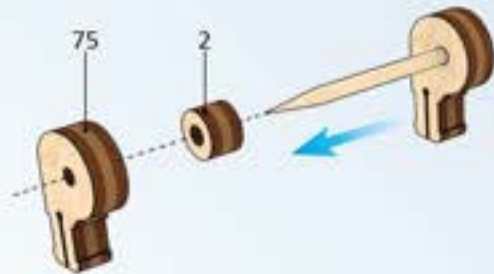

3

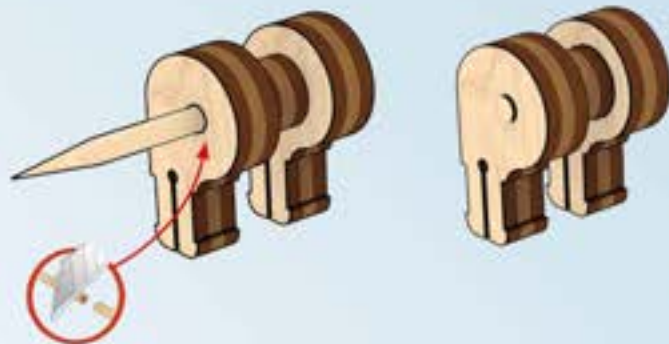

x4



4

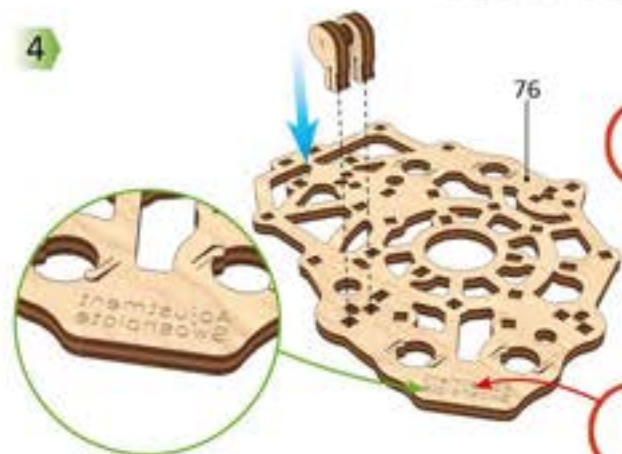

5

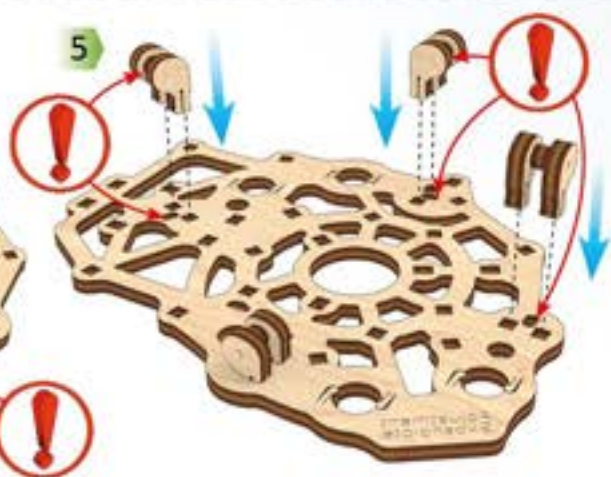

6

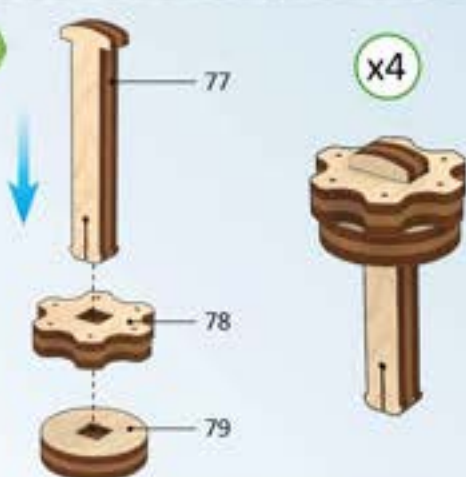

x4

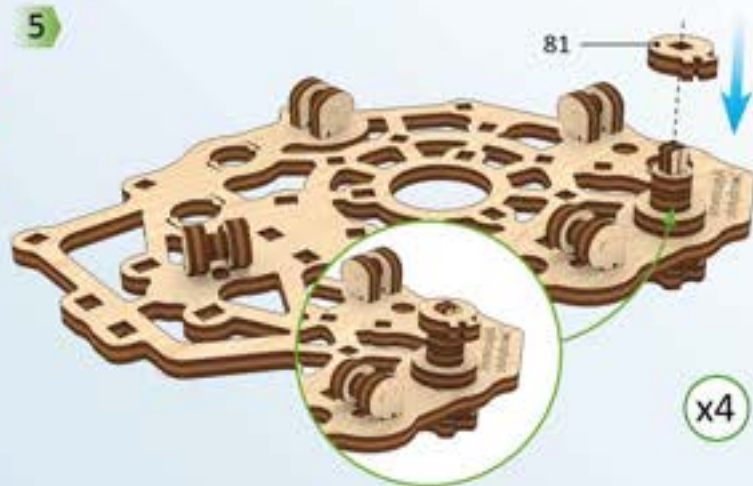
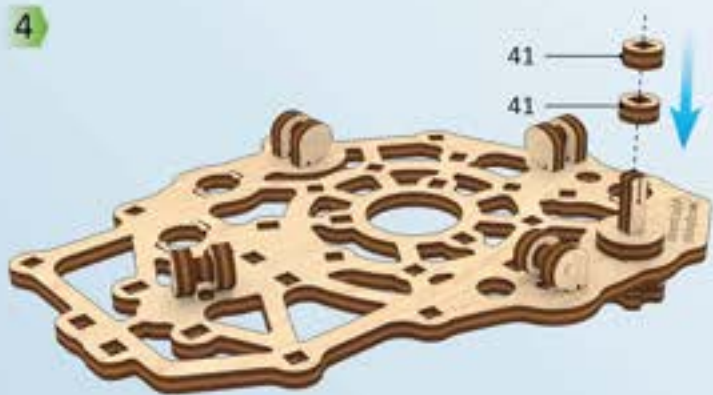
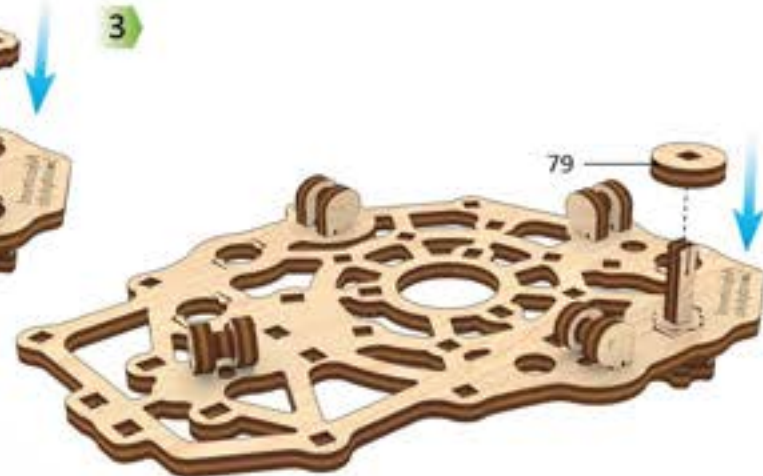



4

1



2

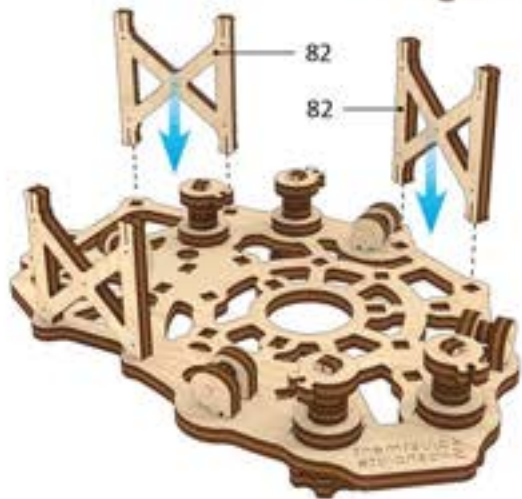

3



4

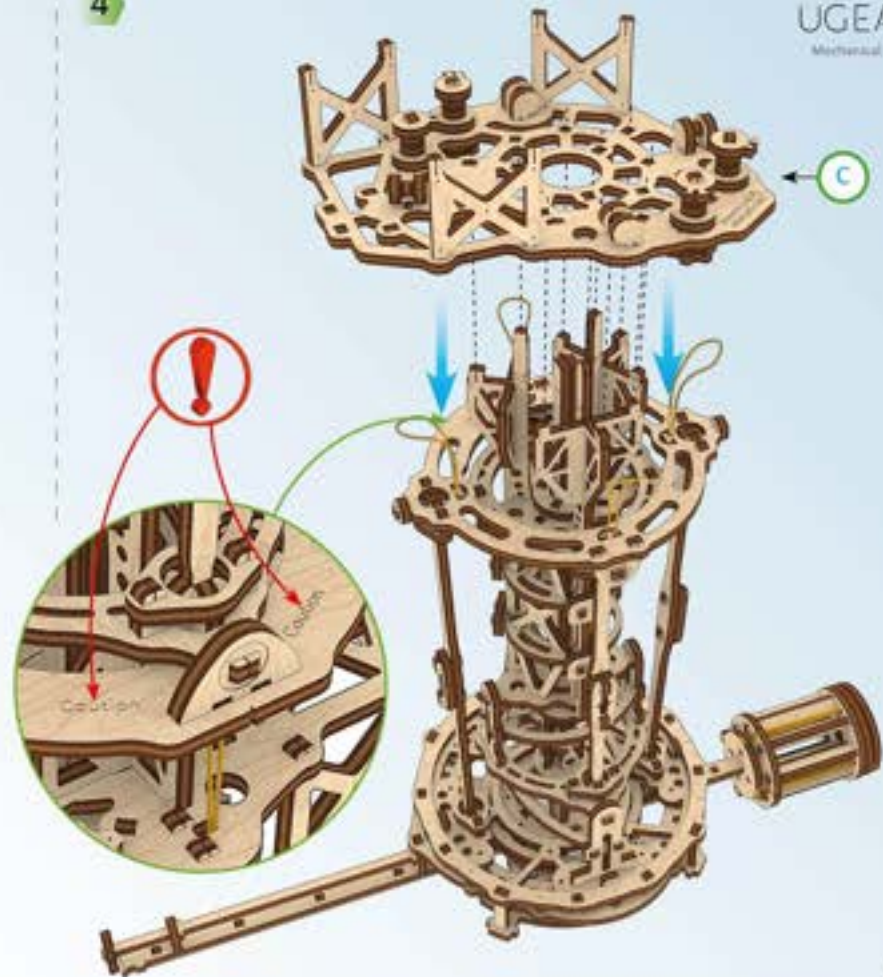

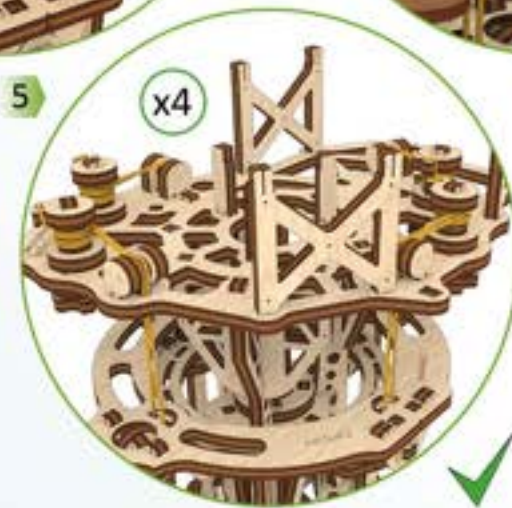
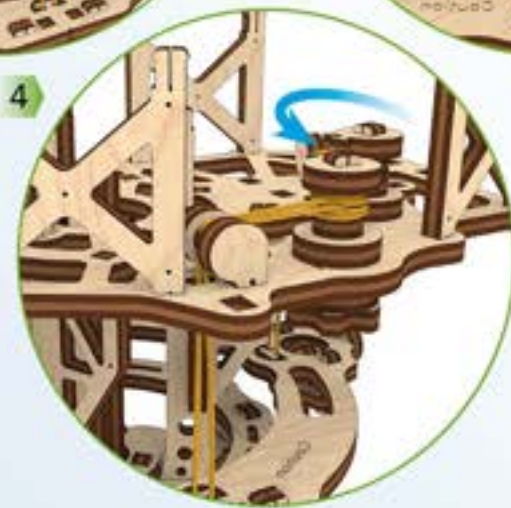
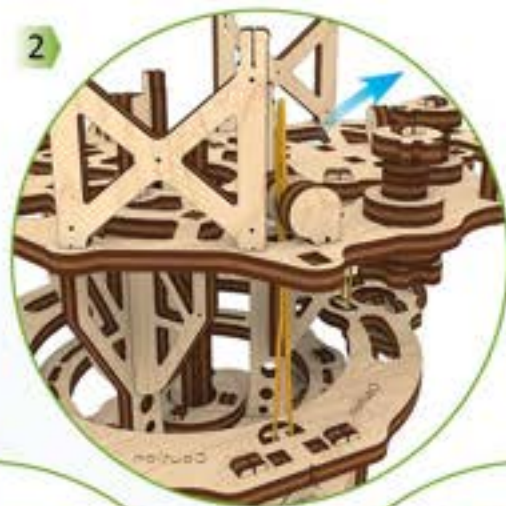
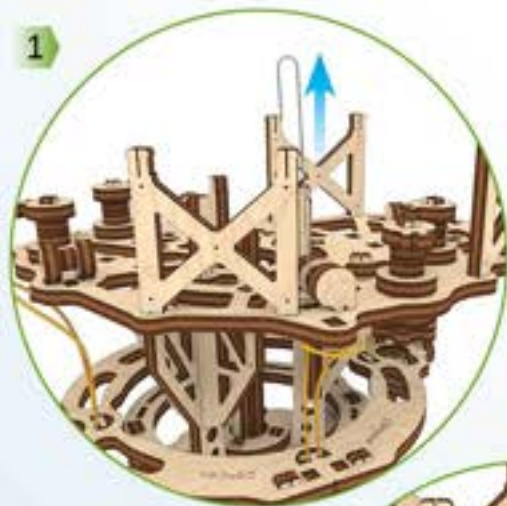
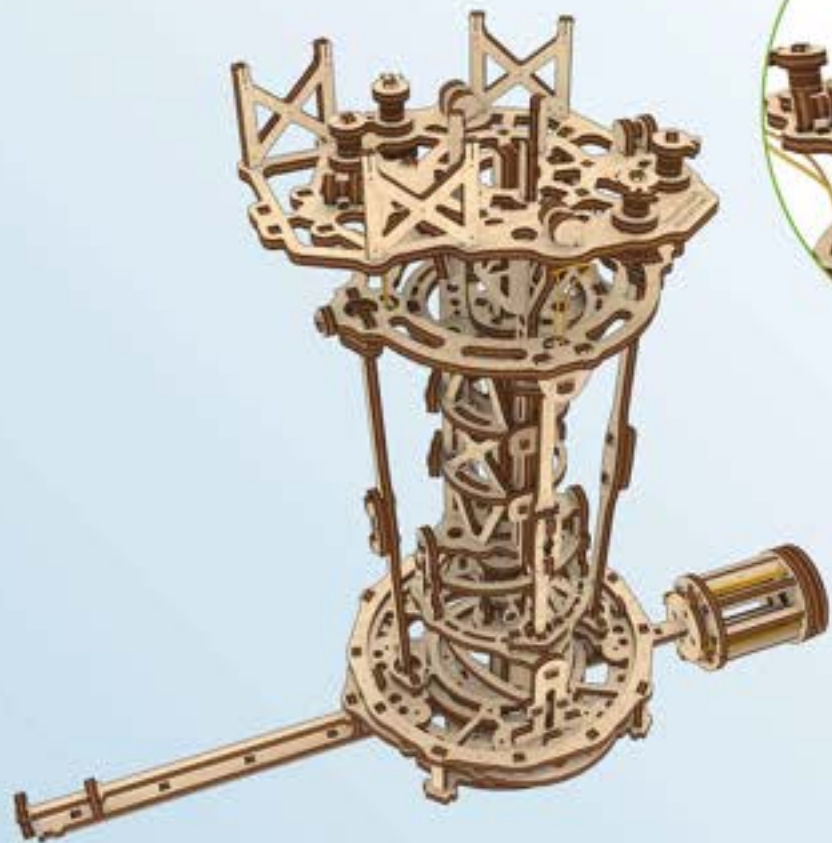



1



2

1

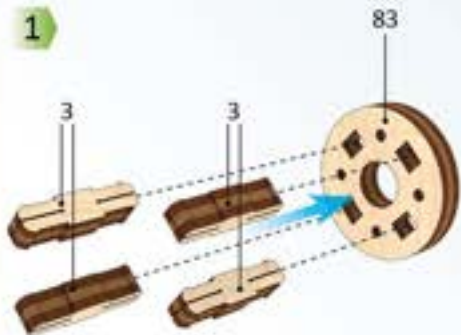

2



x4

3

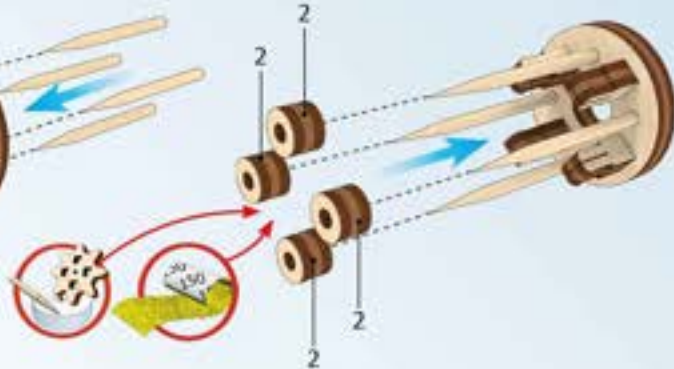

4

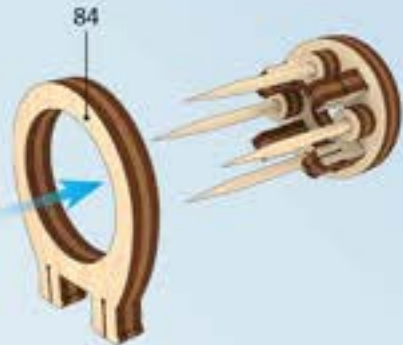

4

5

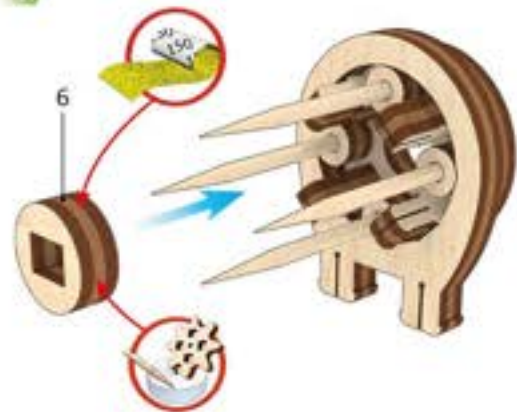

6

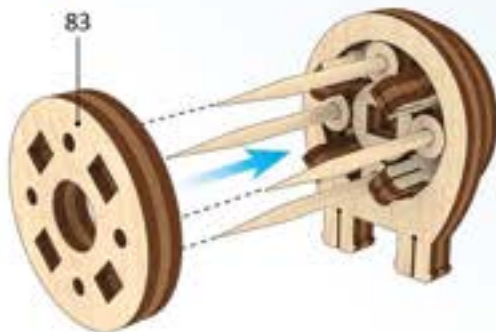

7

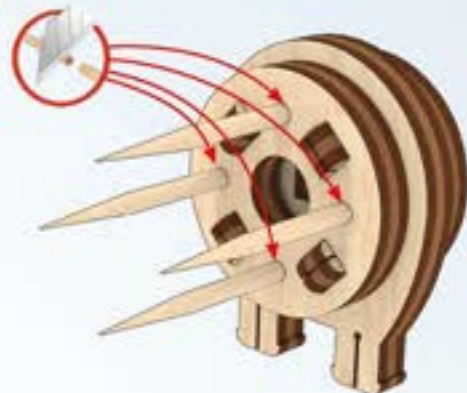

x2





3

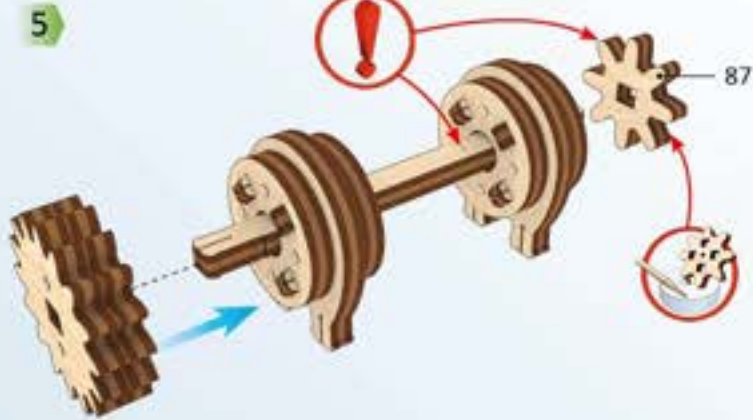
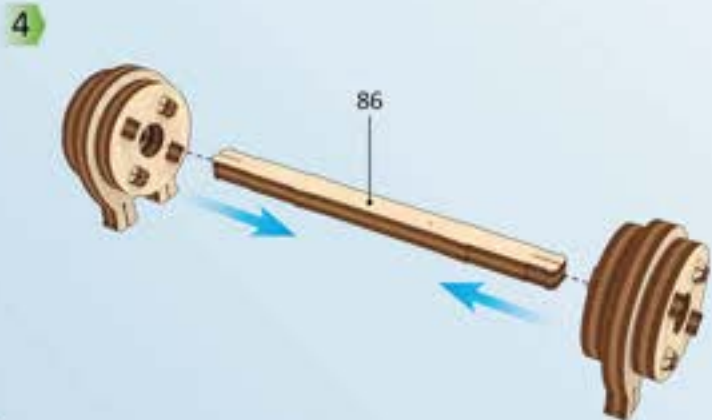
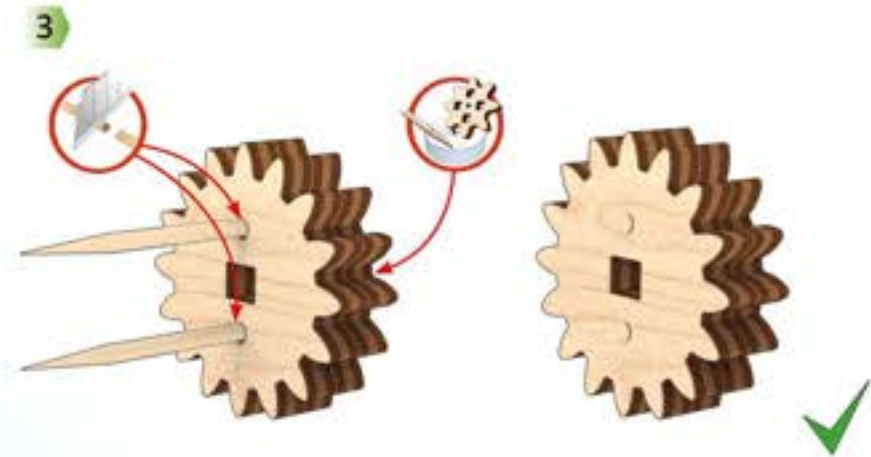
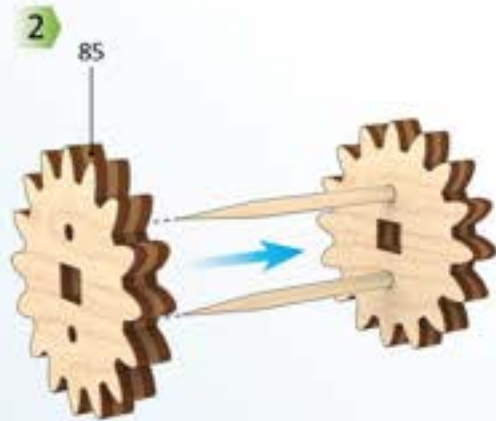
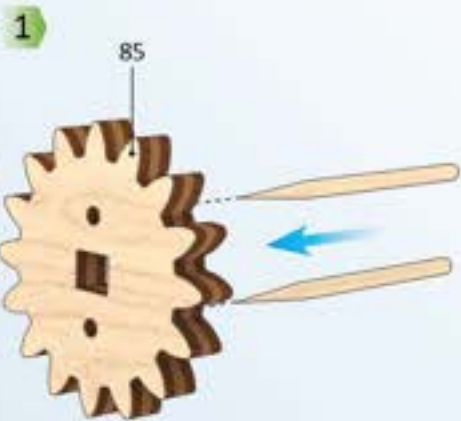



2



3

1

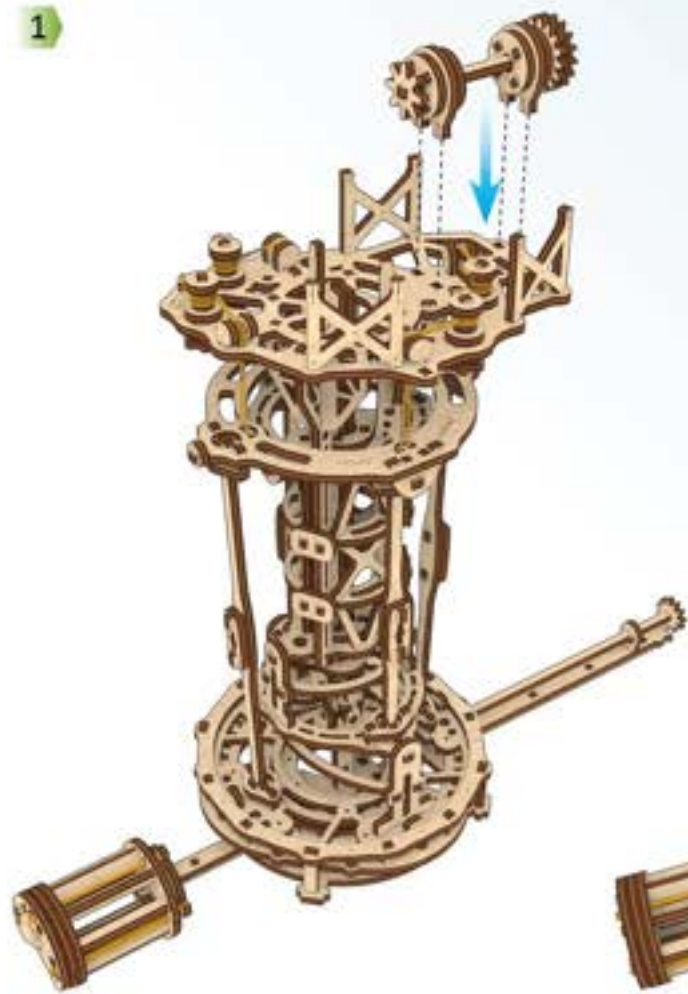

2

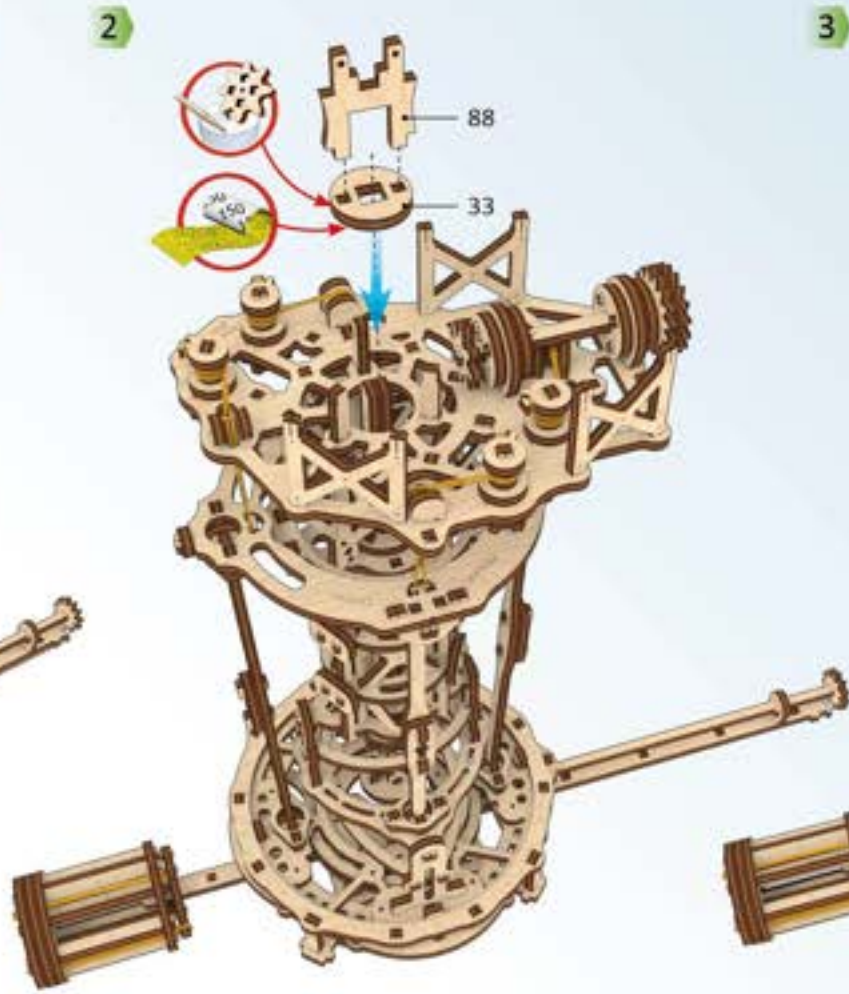

3





1



2

1

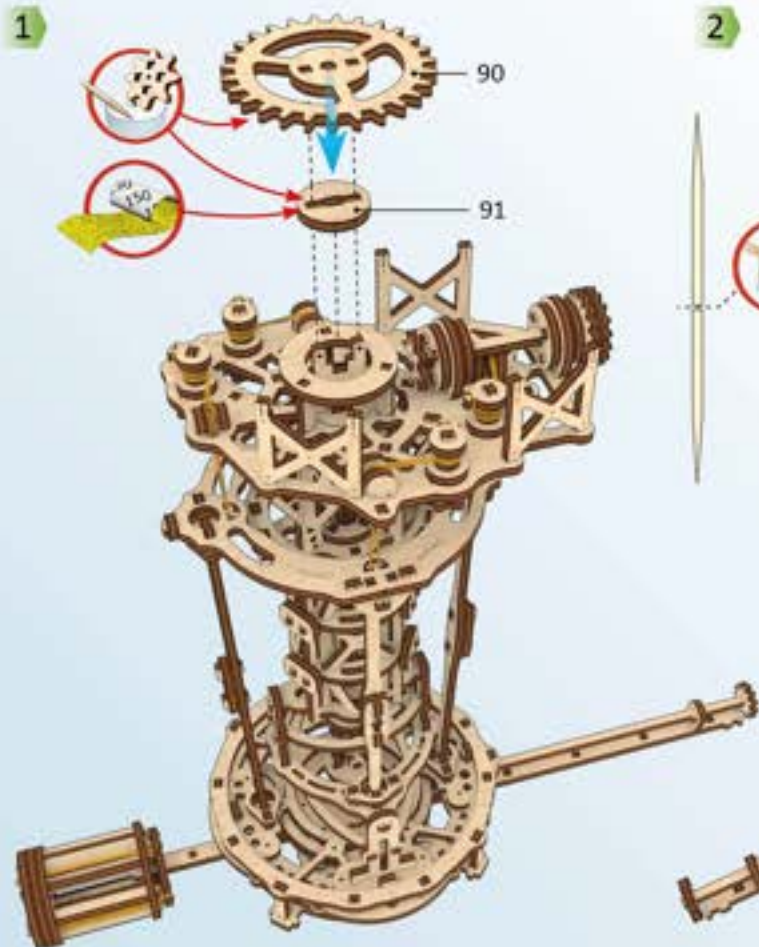

2

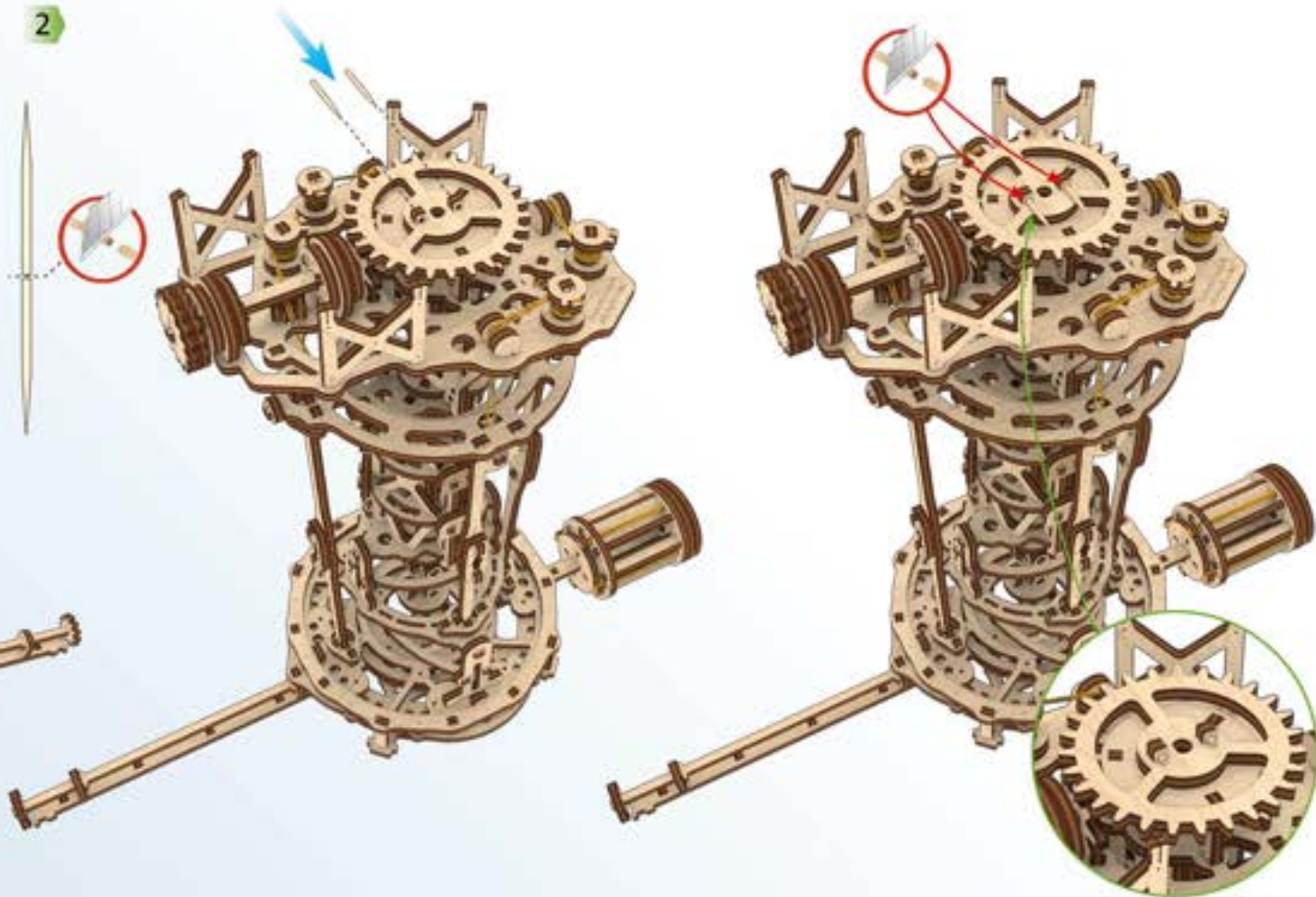

1

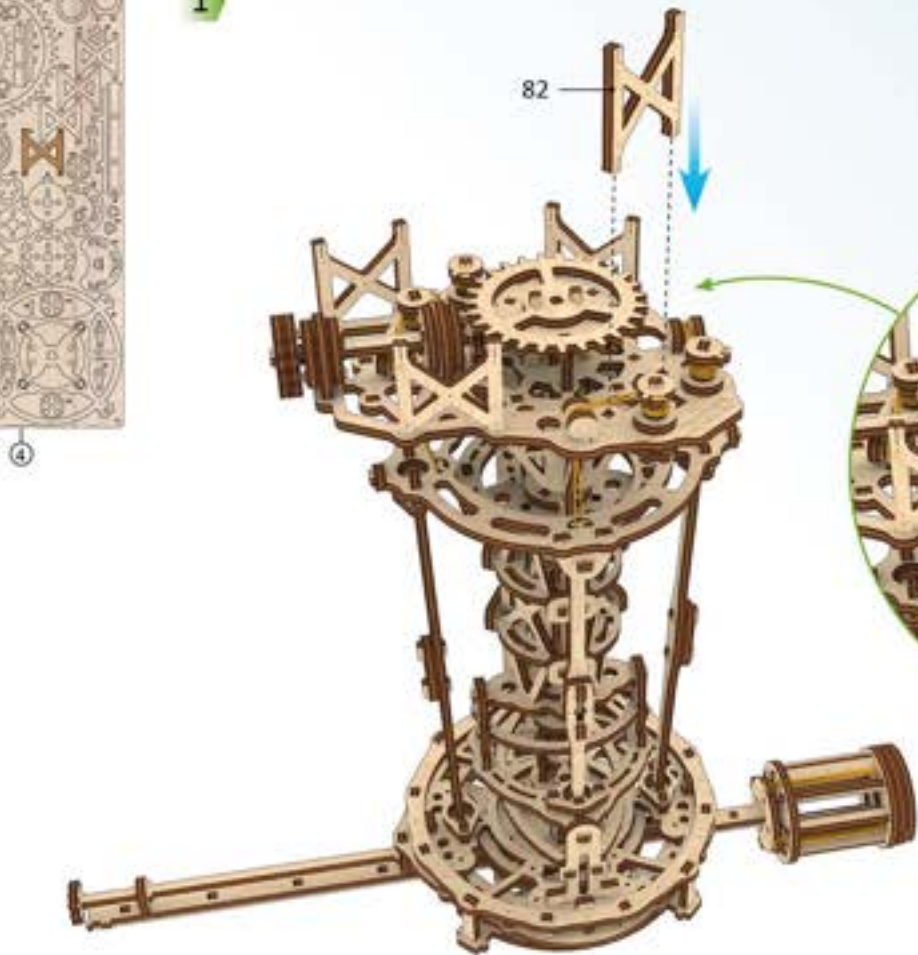

2





5

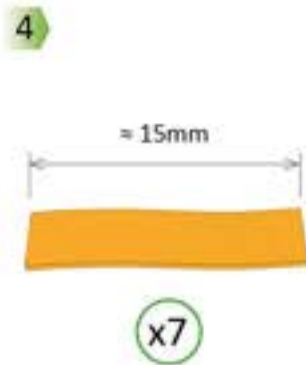
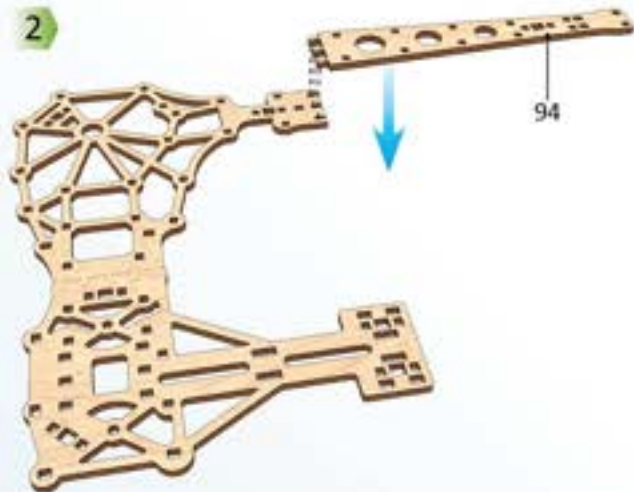
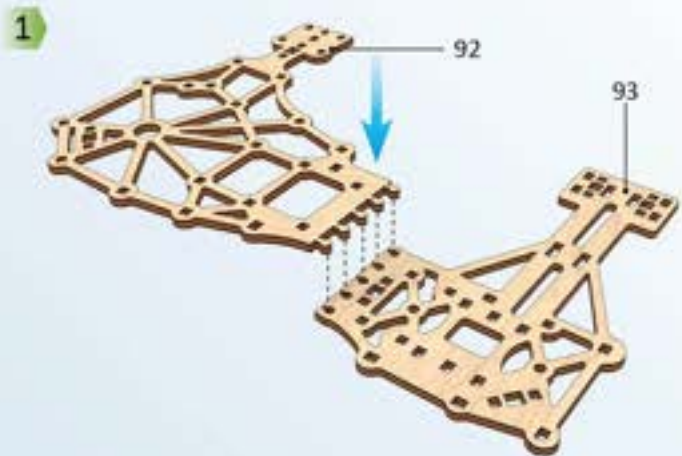

6

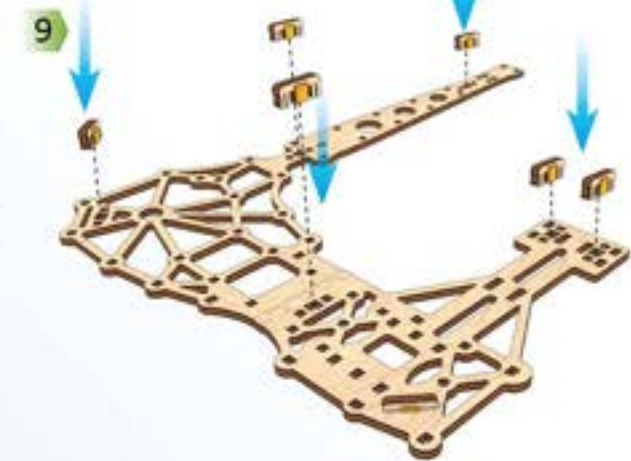

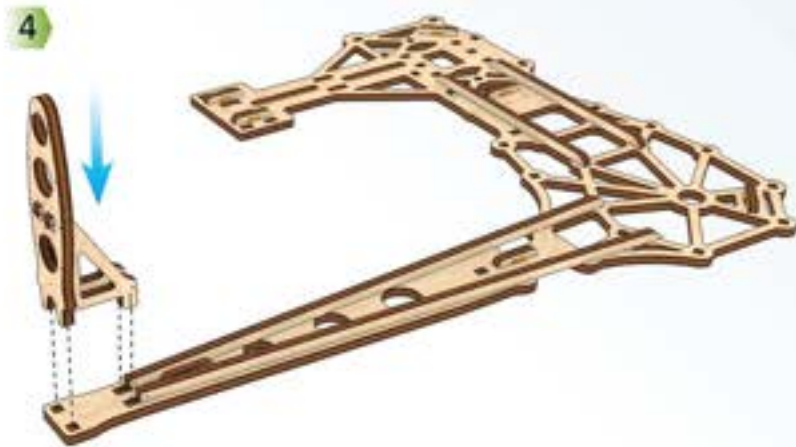
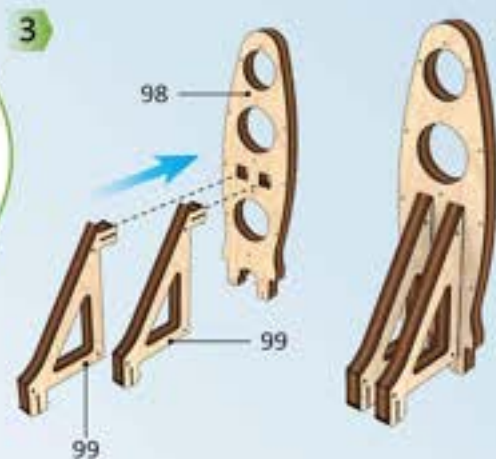
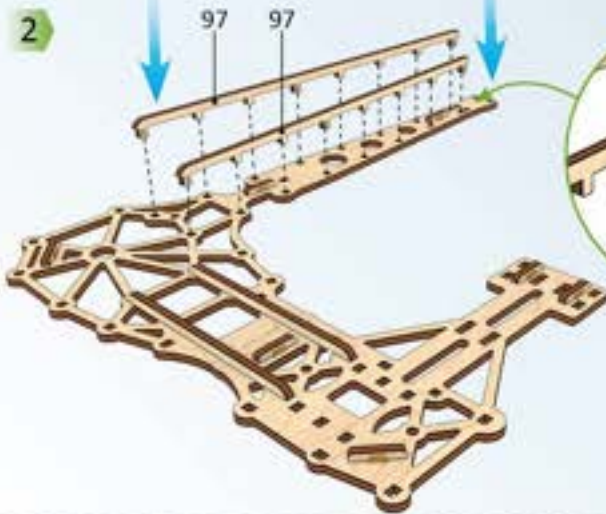
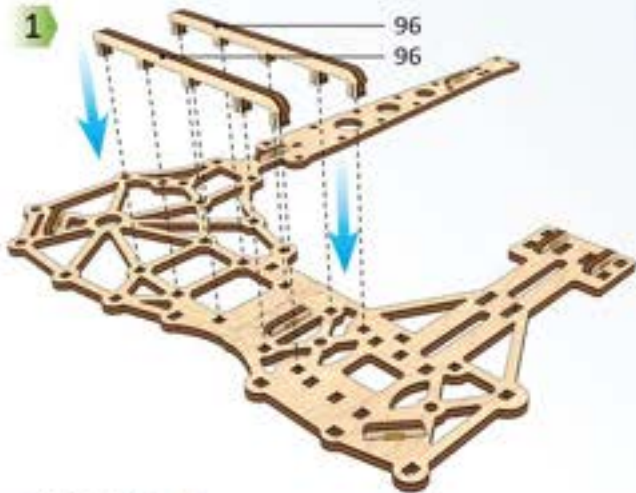



2

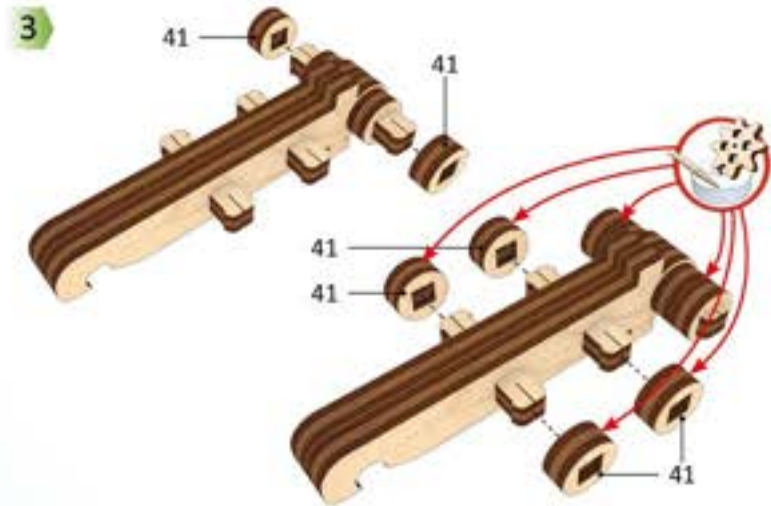
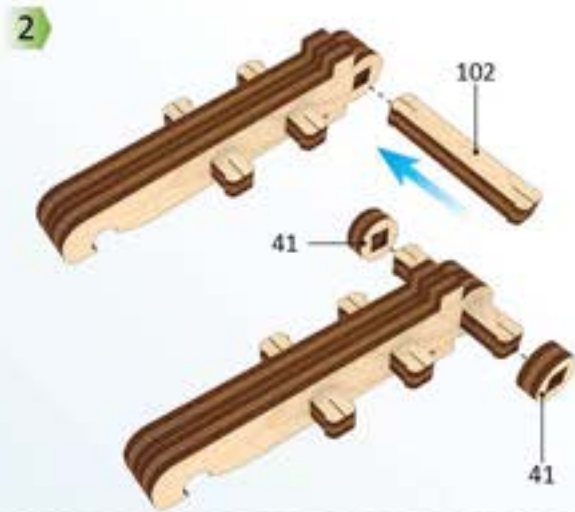
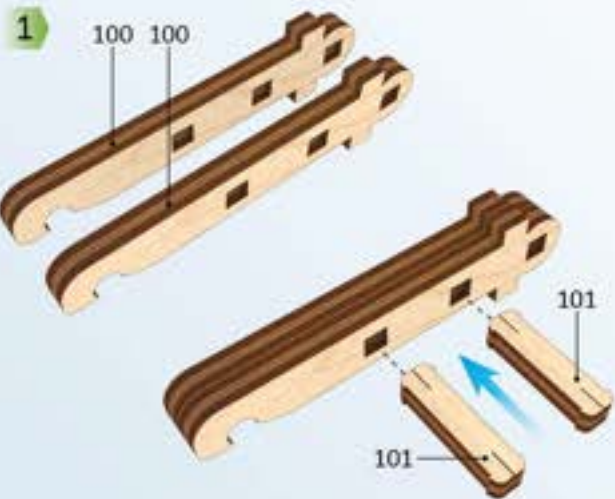

2

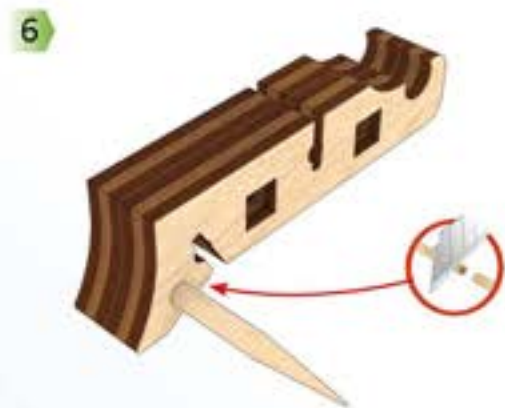
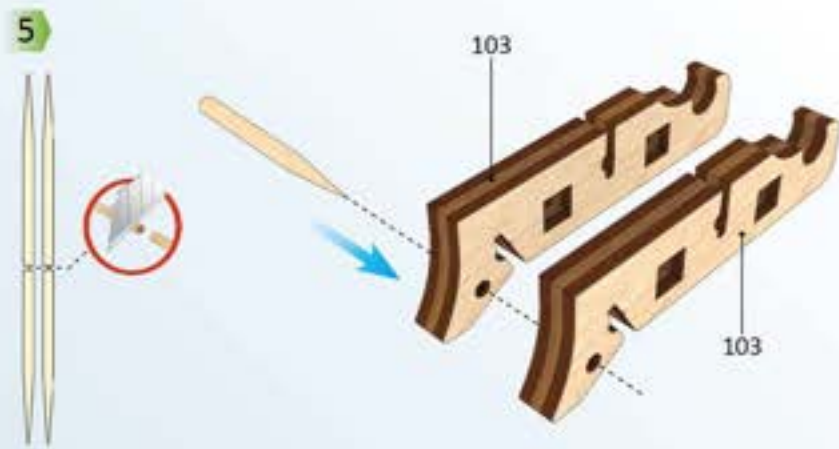



7

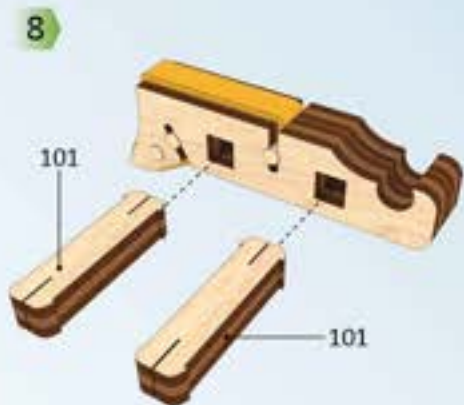
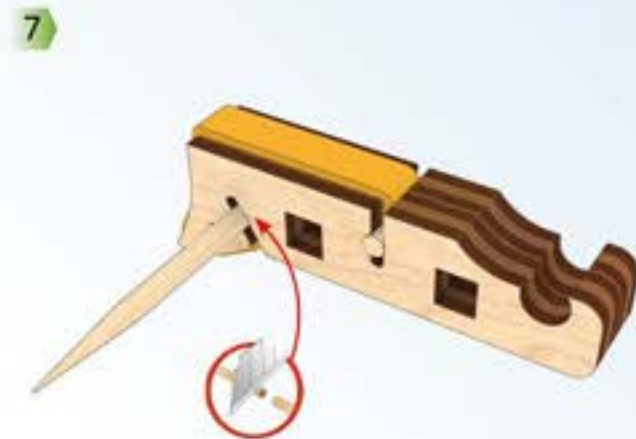
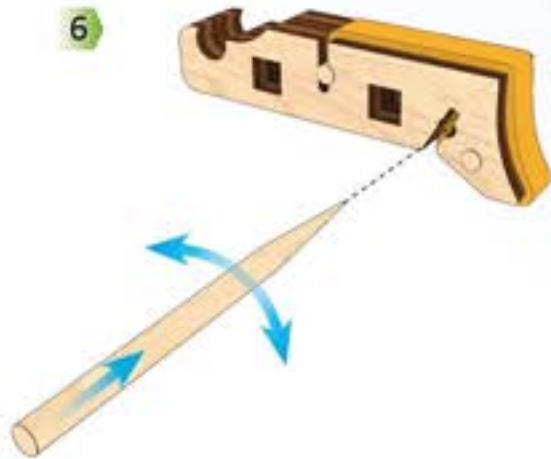
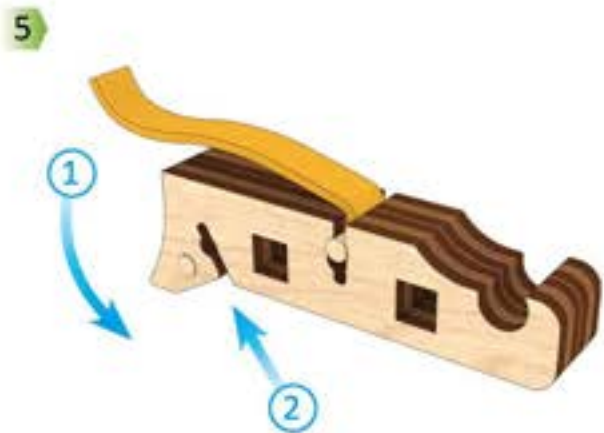
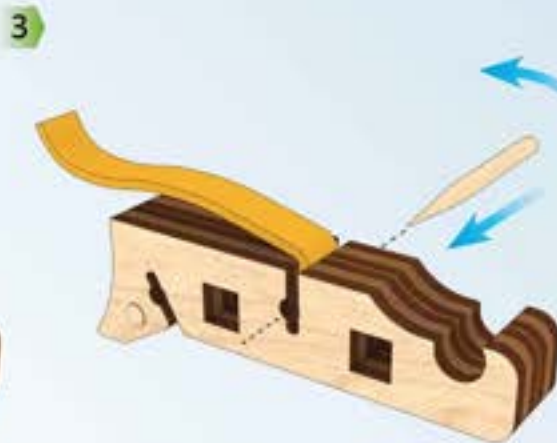
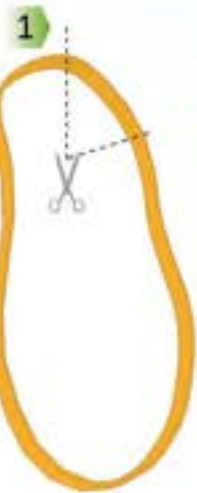



1

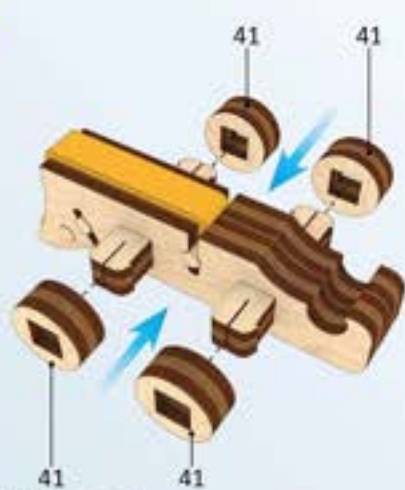

2



3

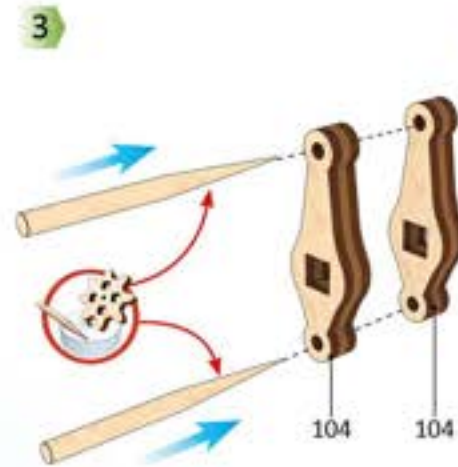

4

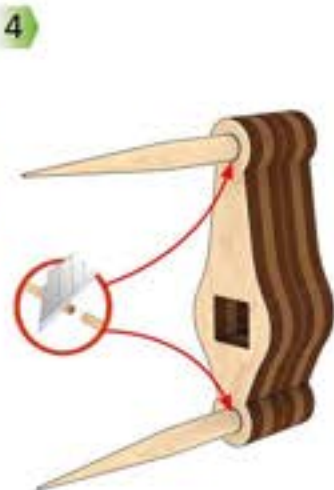

6



7

5



6

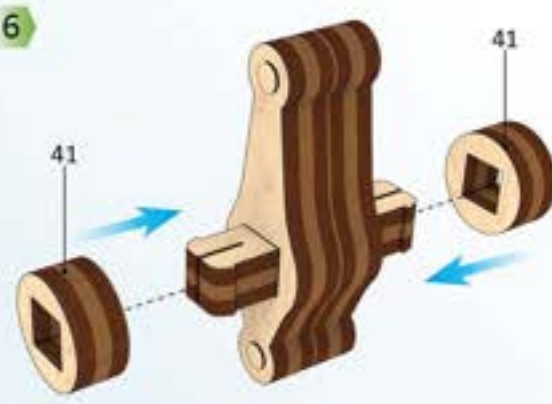

7





5



6

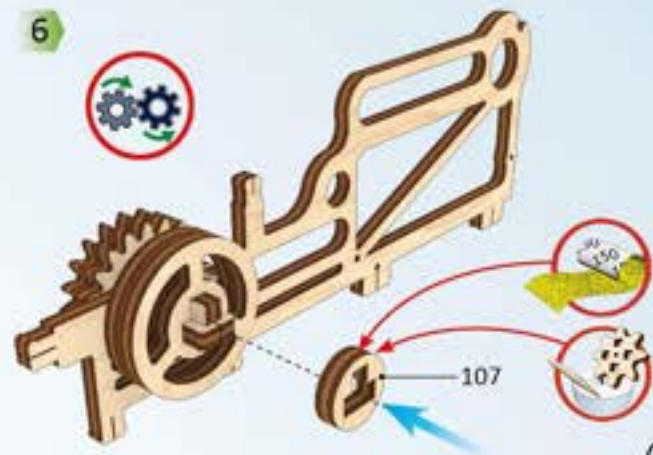
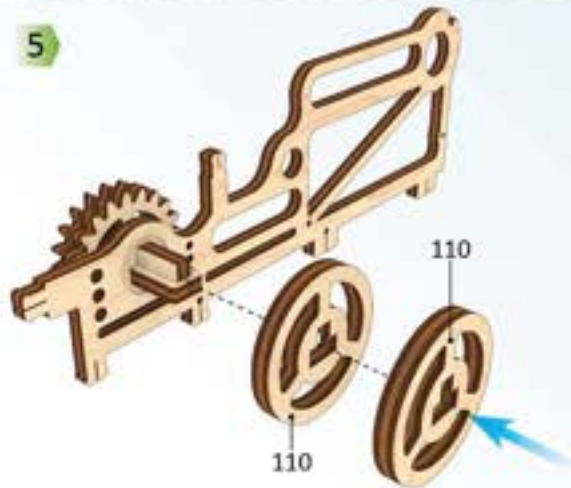
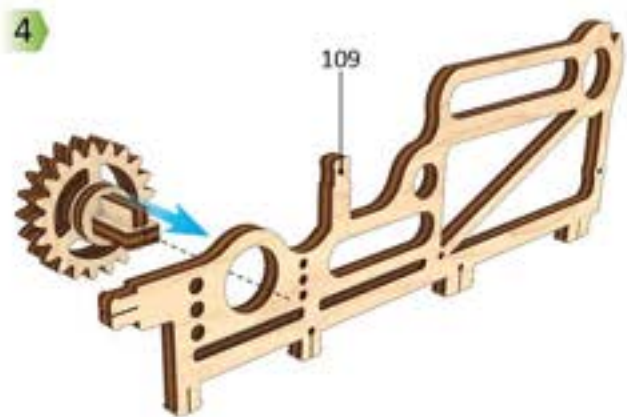
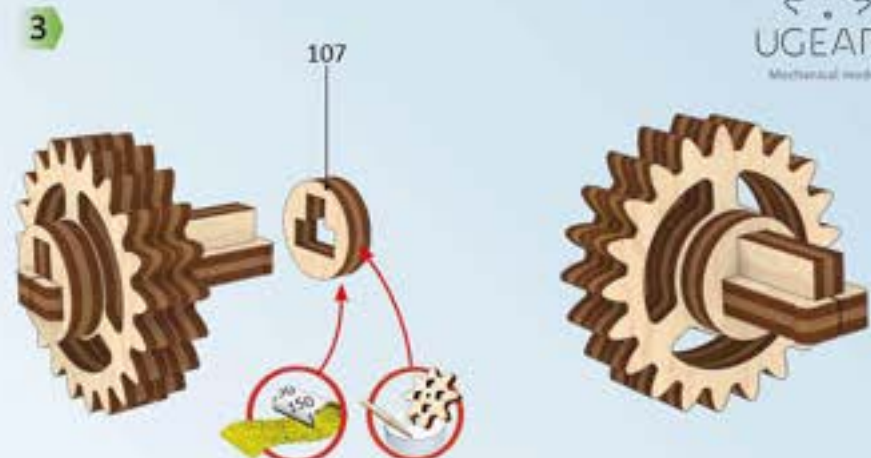
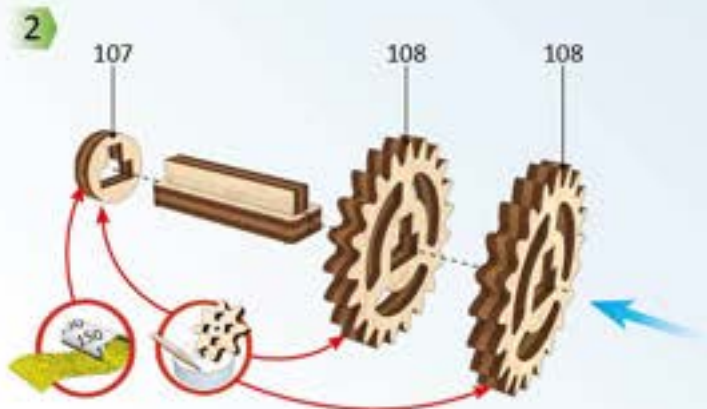
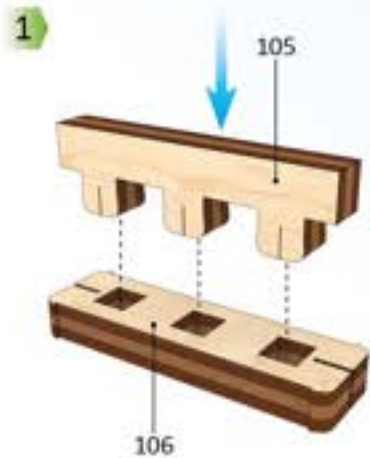



6

1

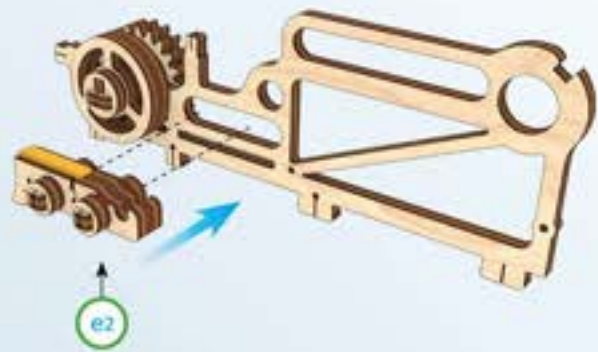

2

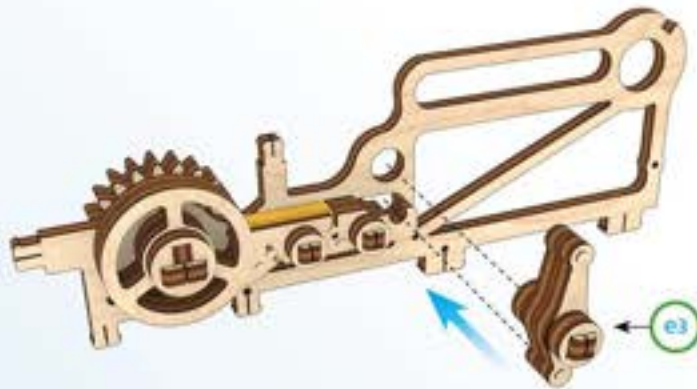

3

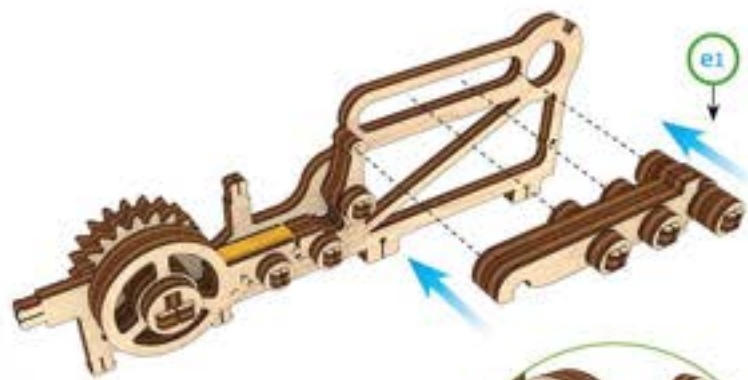

7



8

4

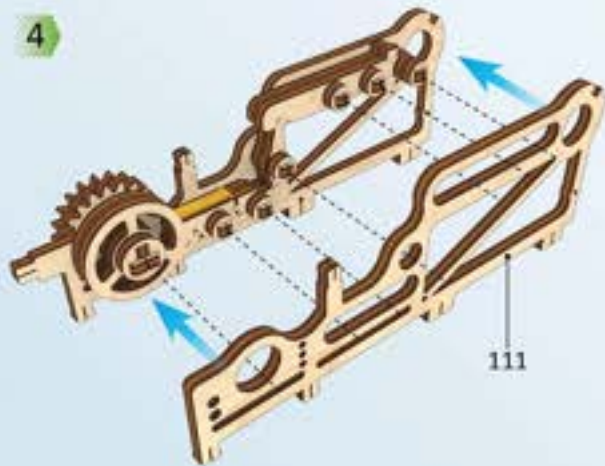

5

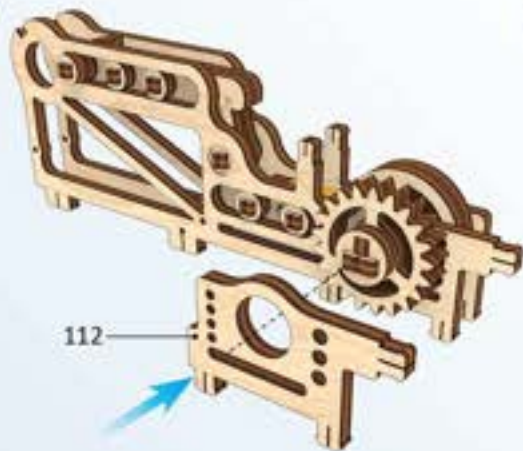

6

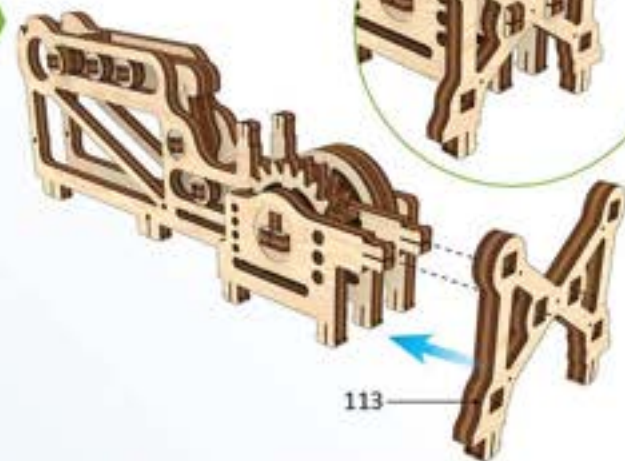



5

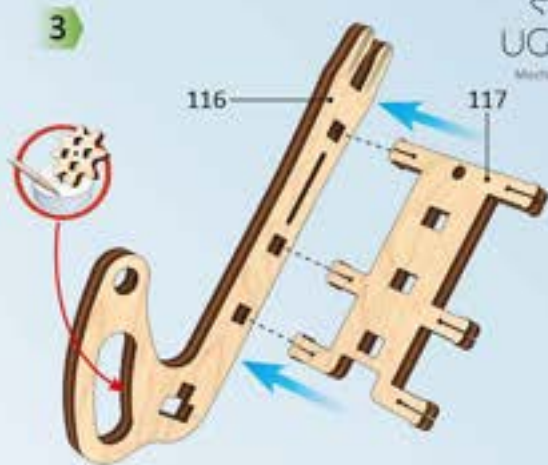
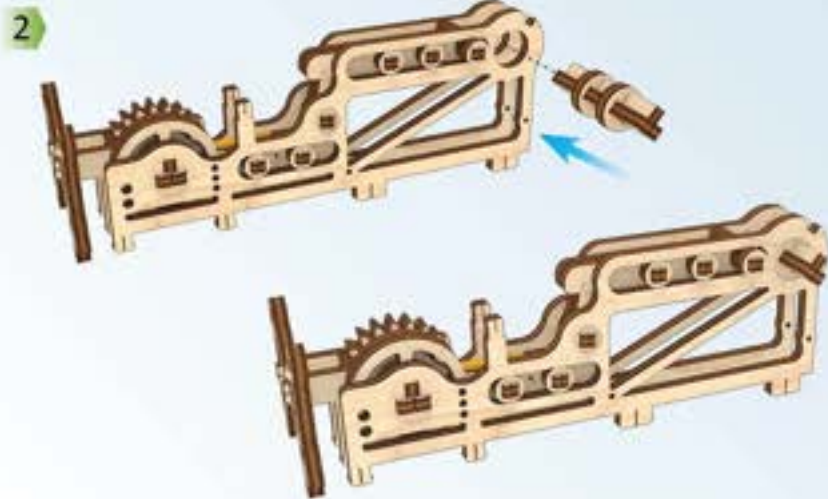
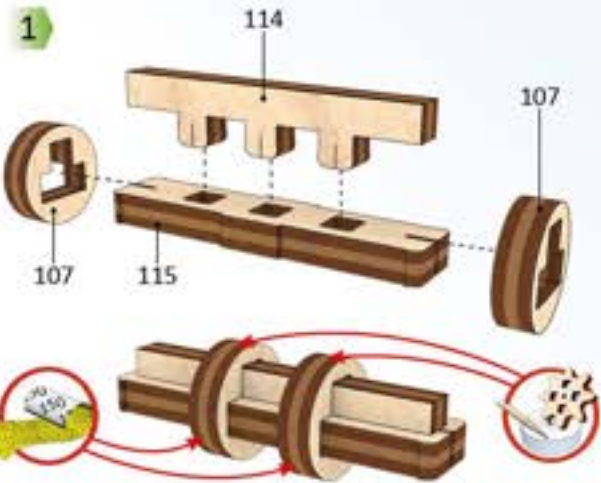

6



7

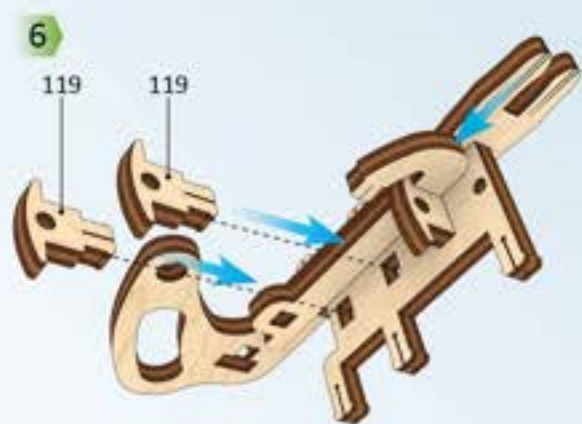
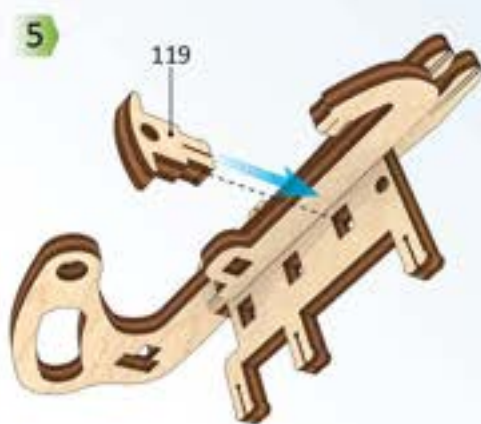
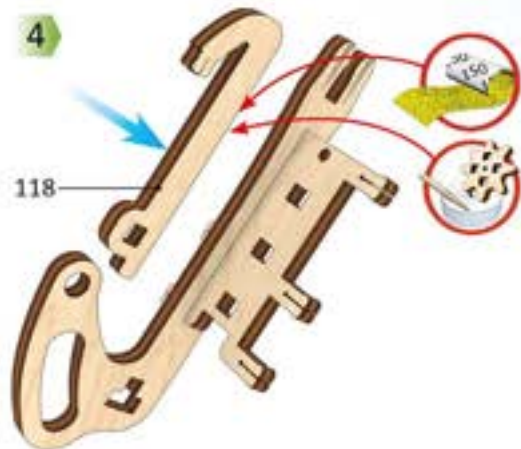



6

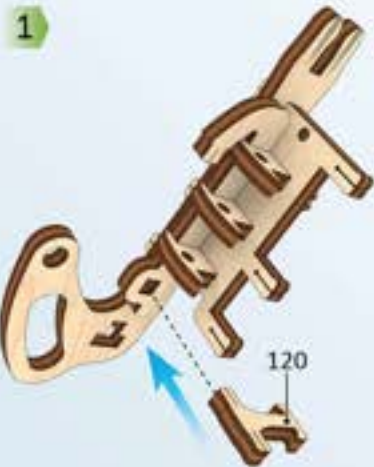

1



2

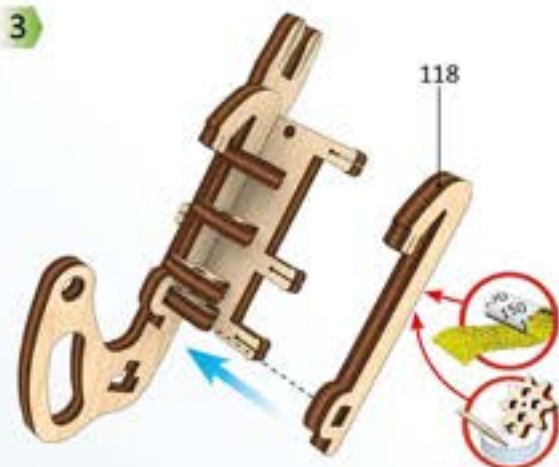

3



4



7



5

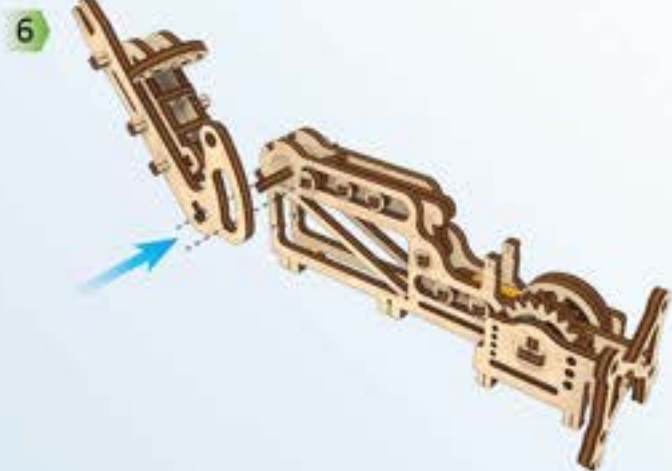

6

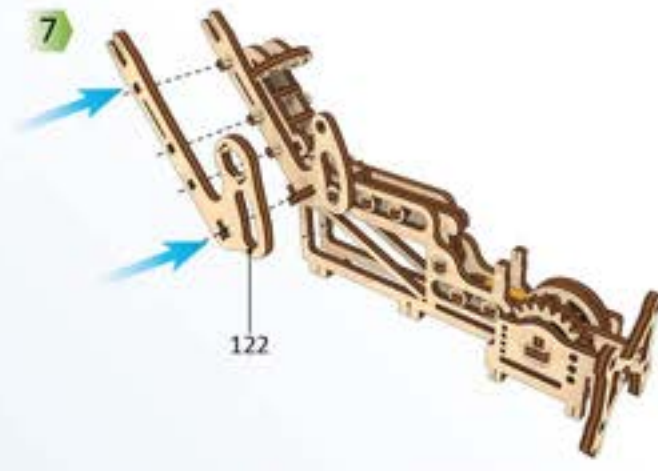

7



6

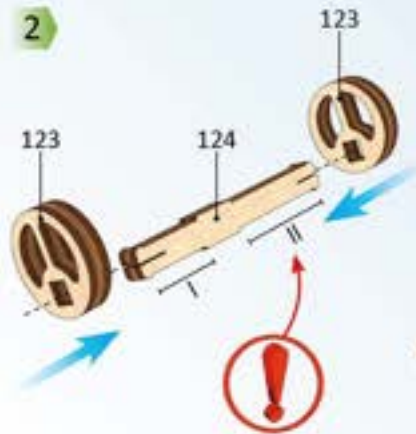

5



7

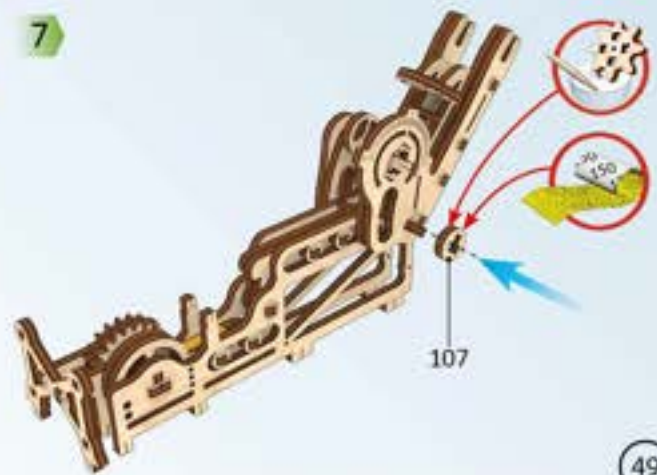
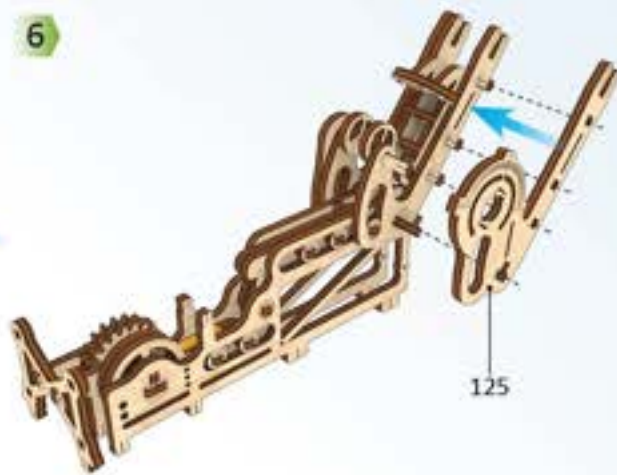
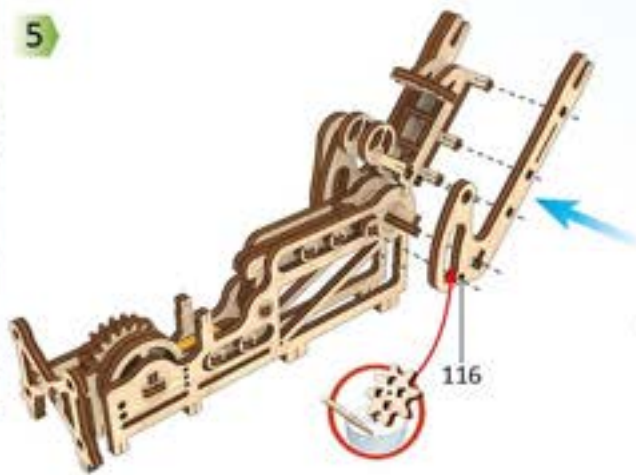



2



5

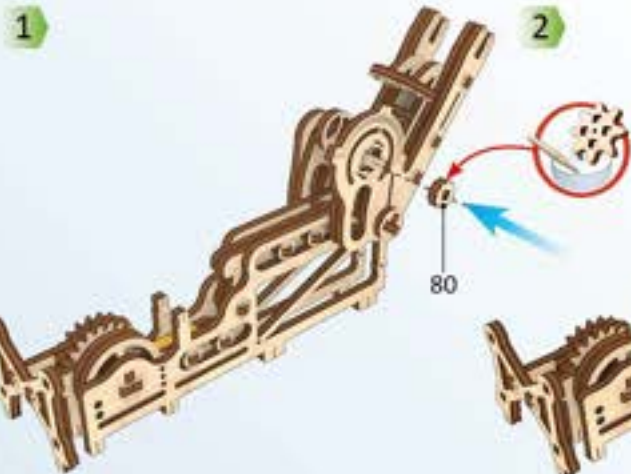

1



2

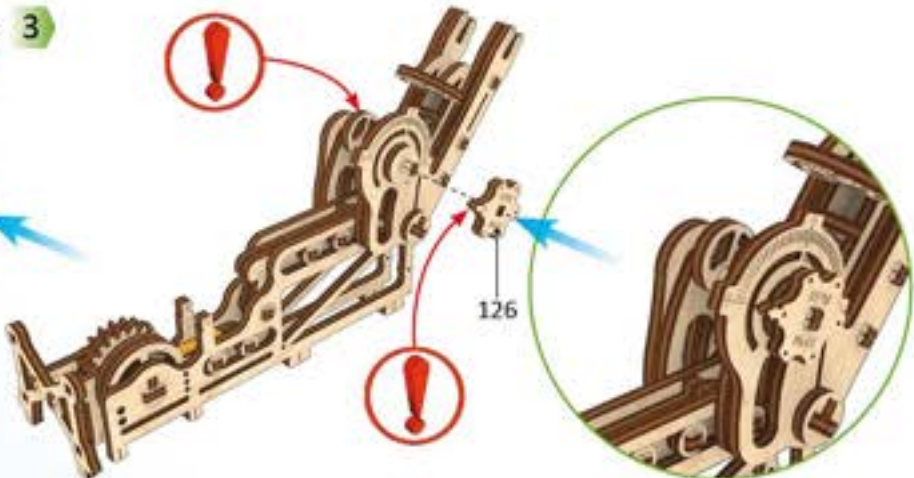

3



6



8



4

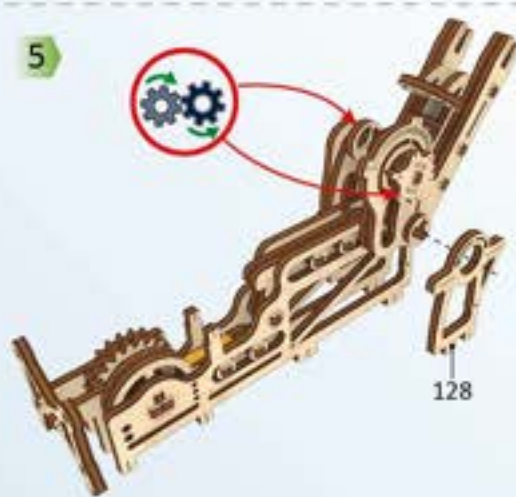

5



6

1



2

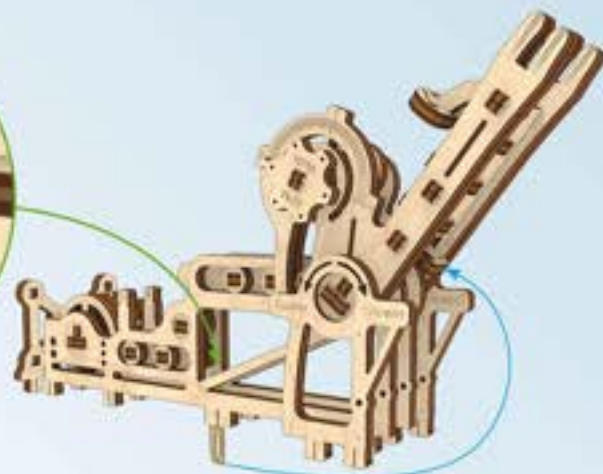

3

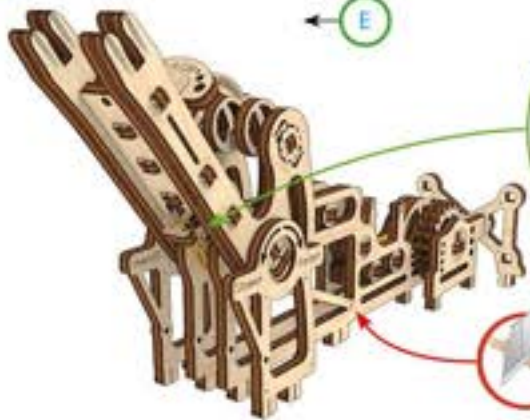

4

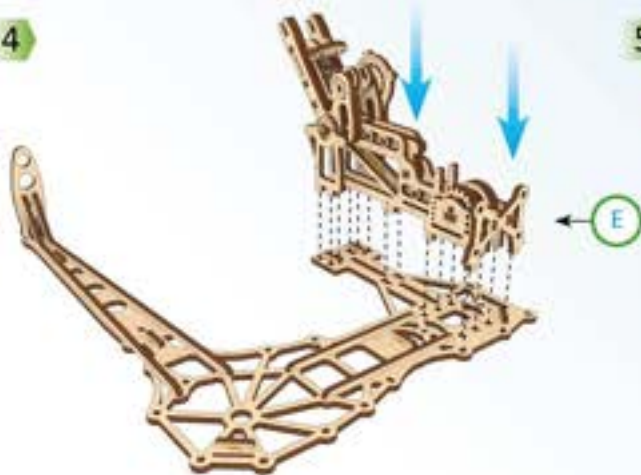

5



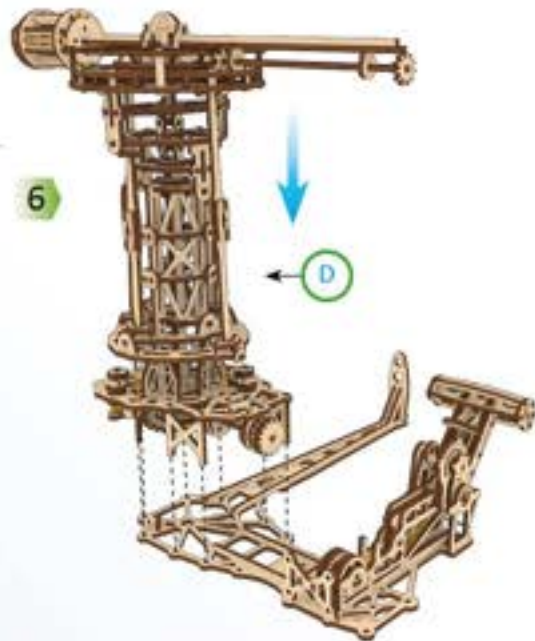
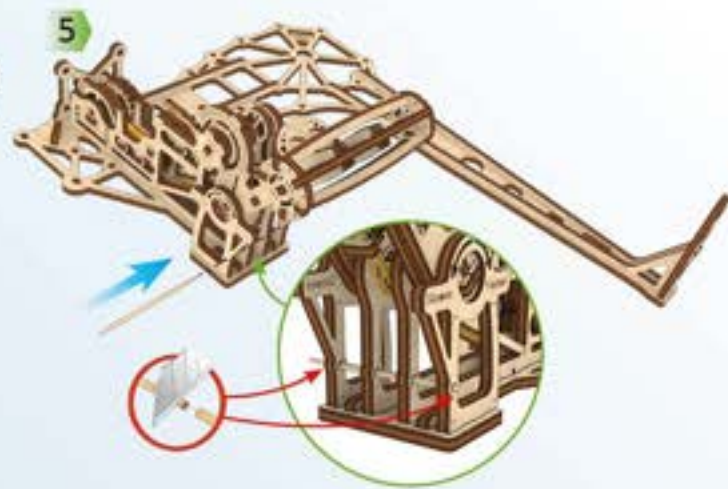
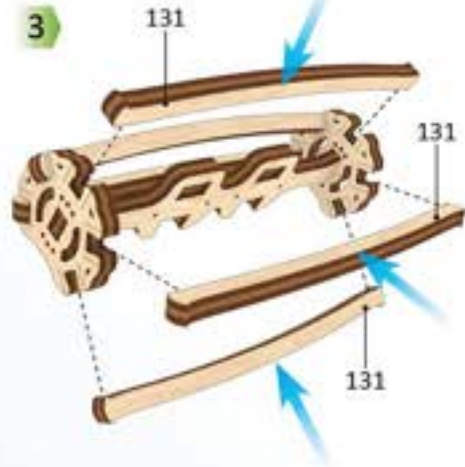
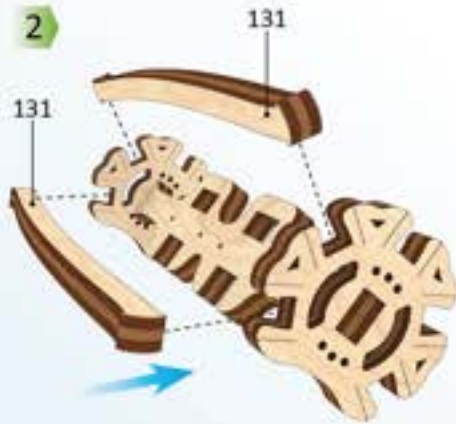
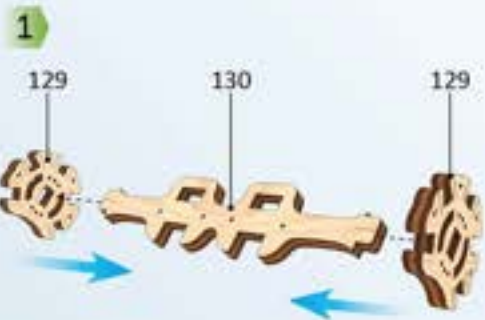



7

1

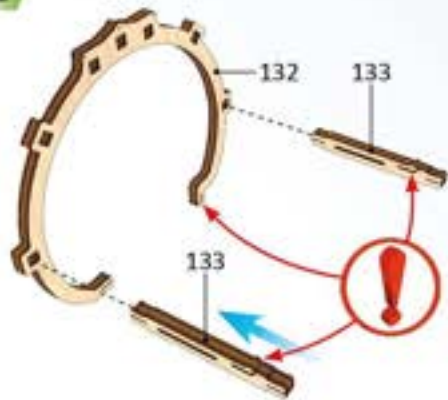

2

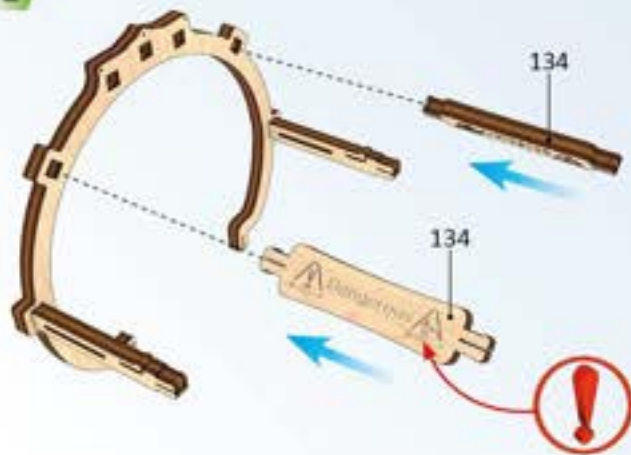

3

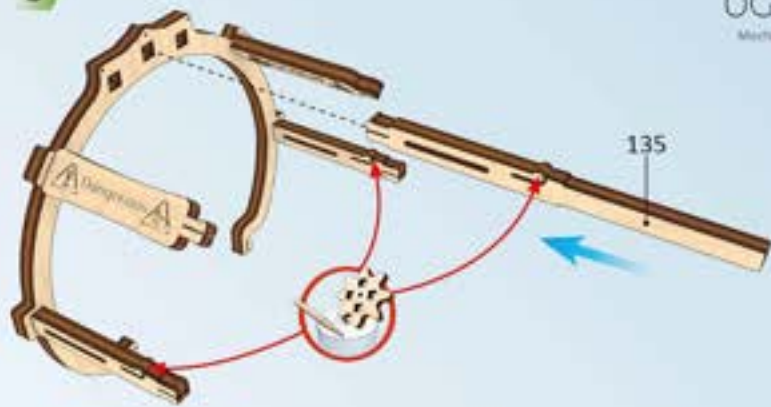

8

4

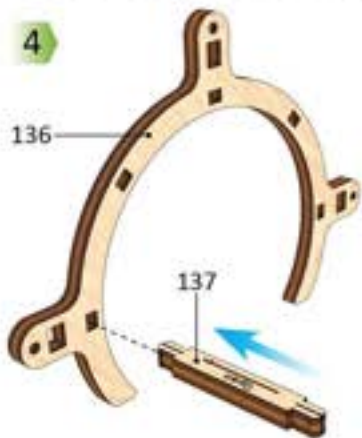

5

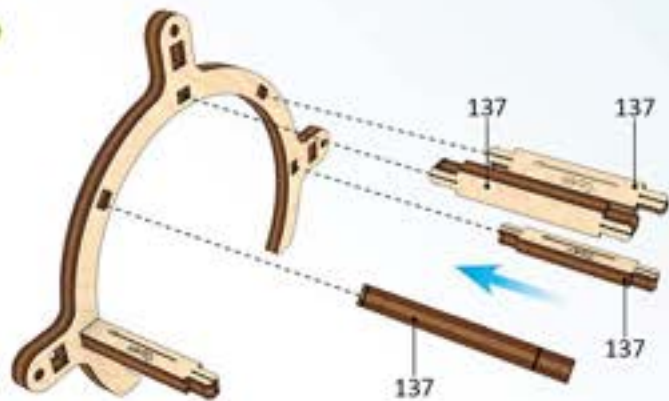

6

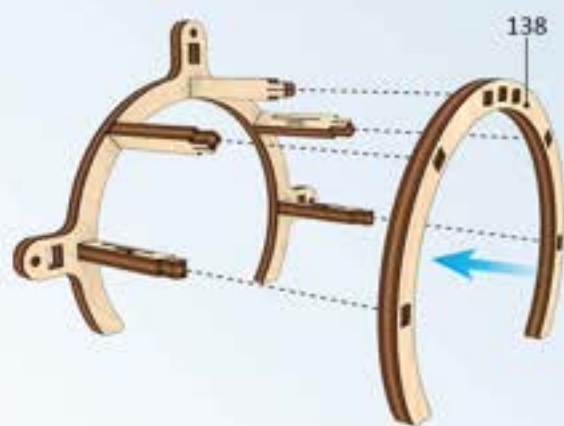



6

1

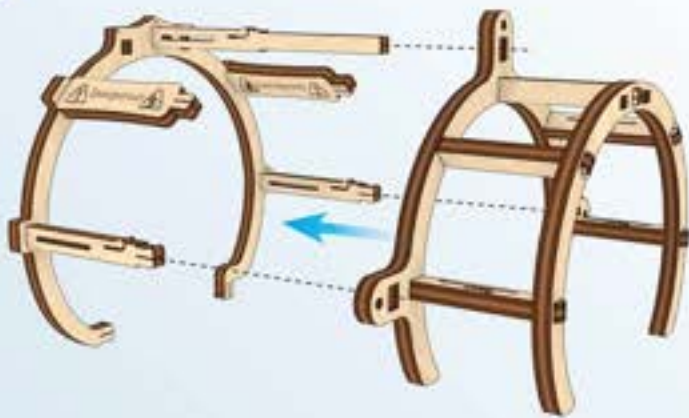

2

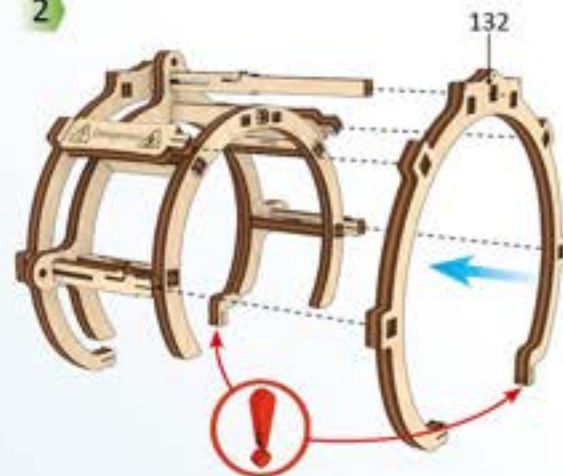

3



4

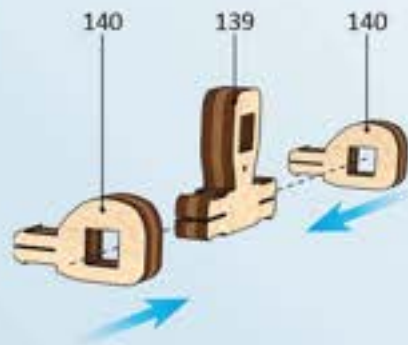

5

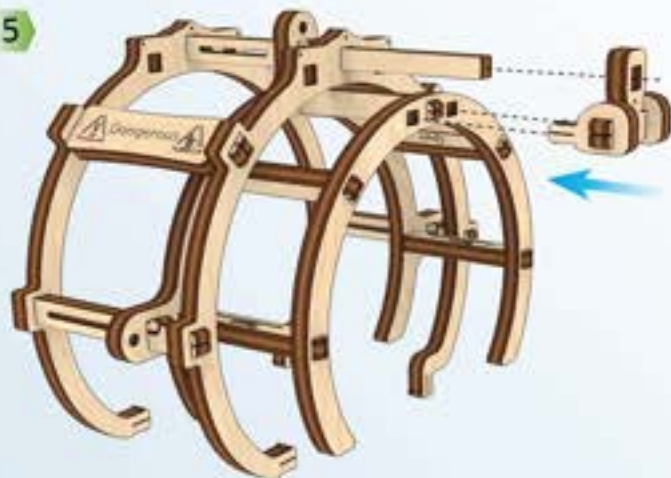

6



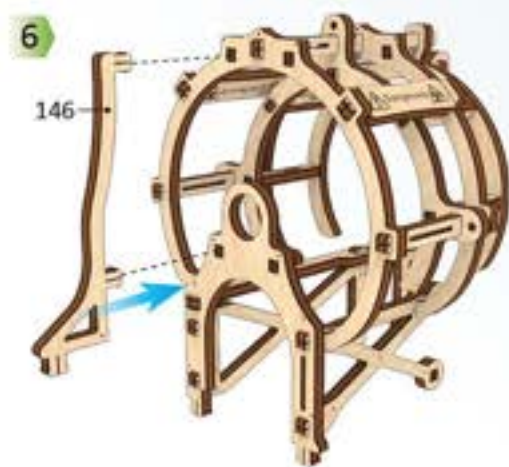
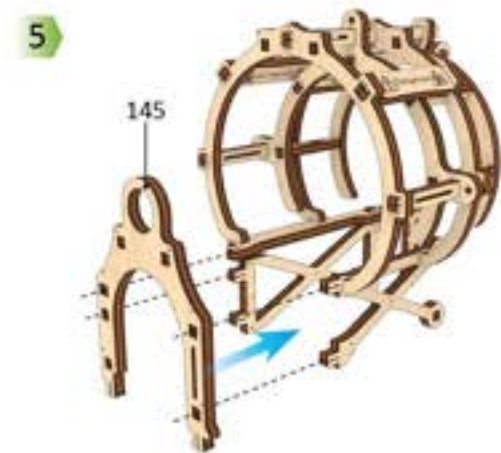
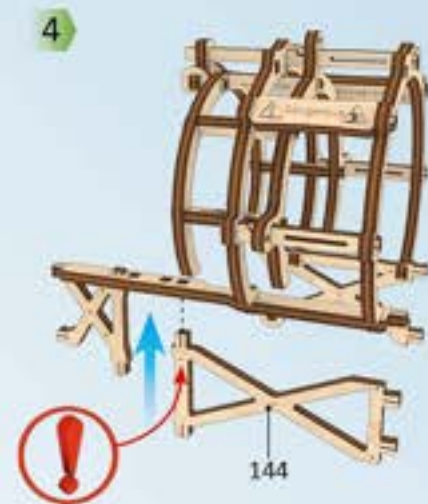
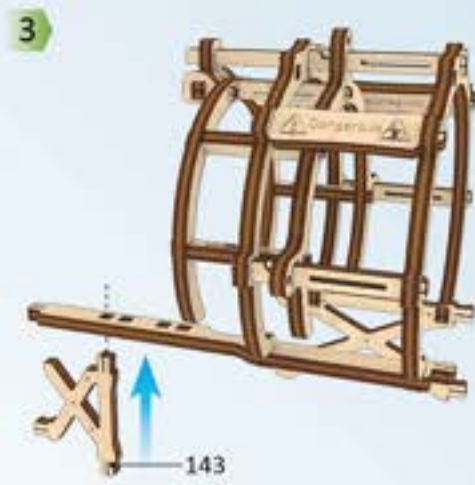
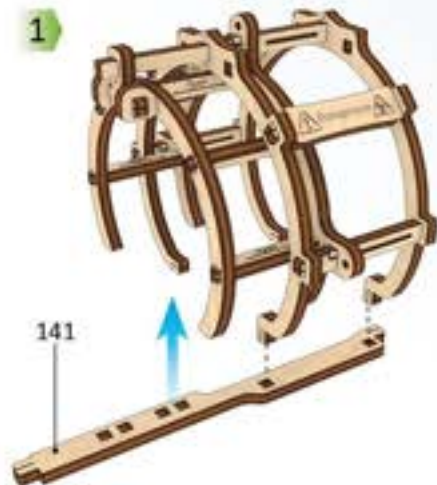



4



1



147

2

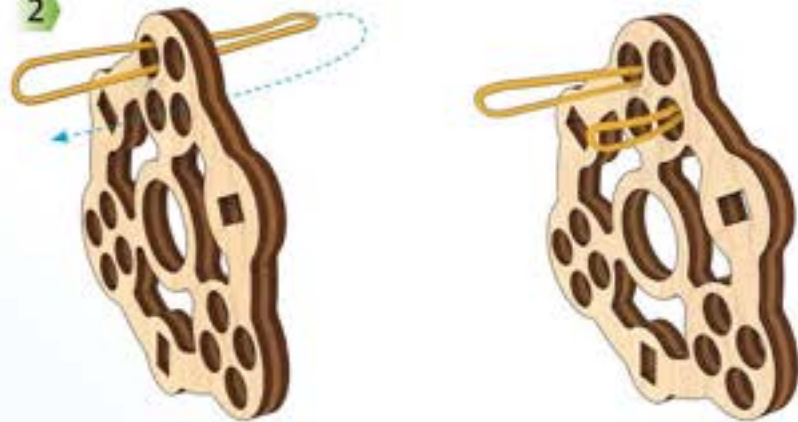

3



x5

4



148

5

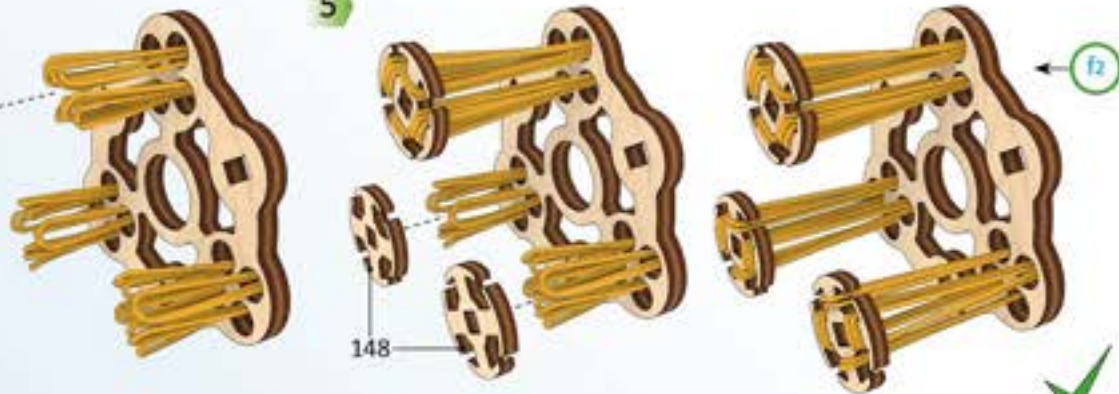

148

fz



5



3

1

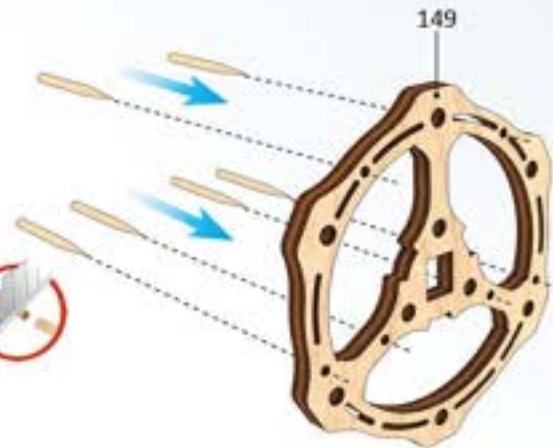

2

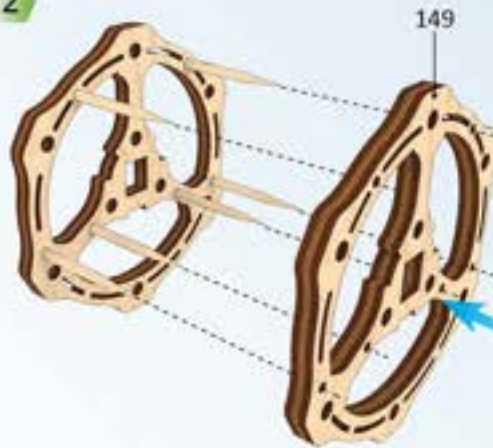

3

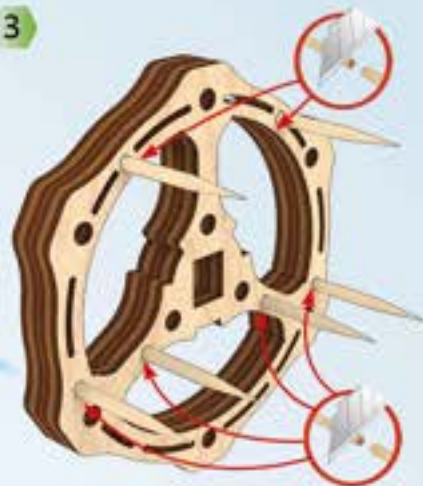

fs



6

4

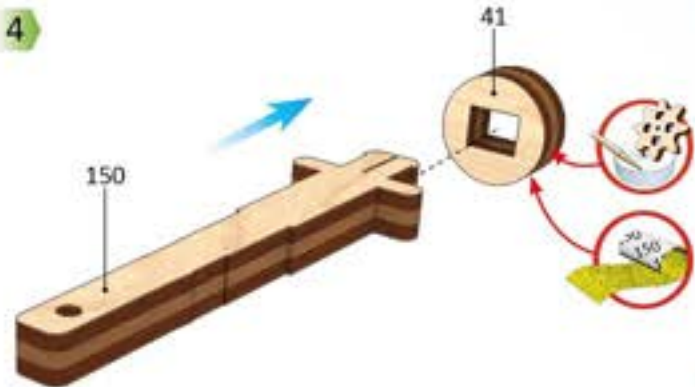

5

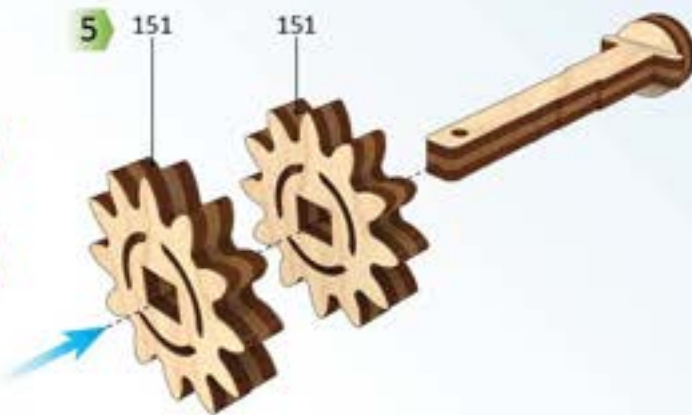

6



x3



57



3



4

1

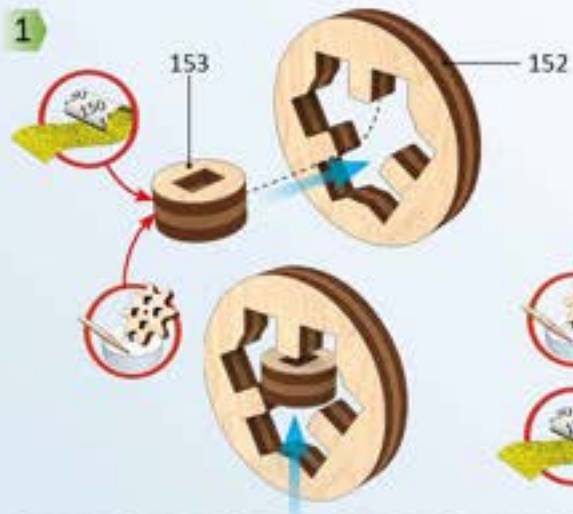

2

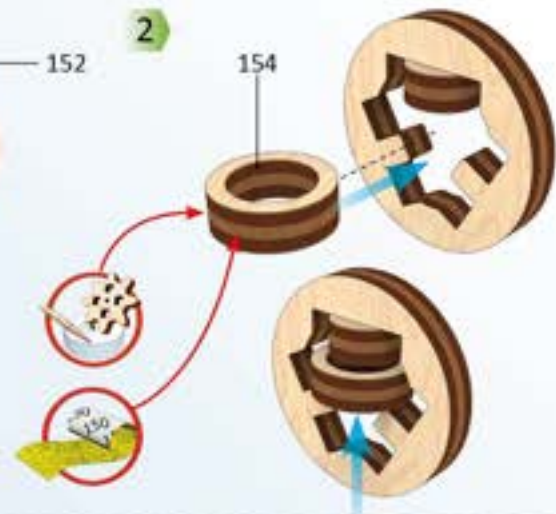

3

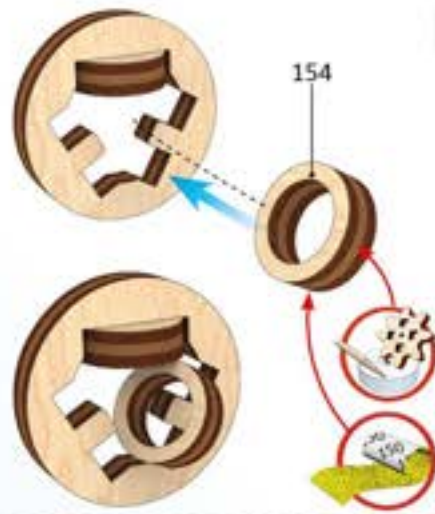

4

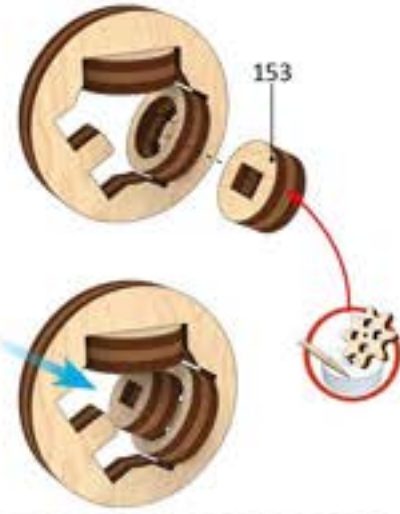

5

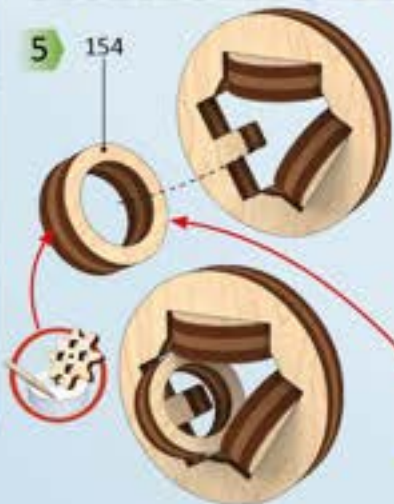

6

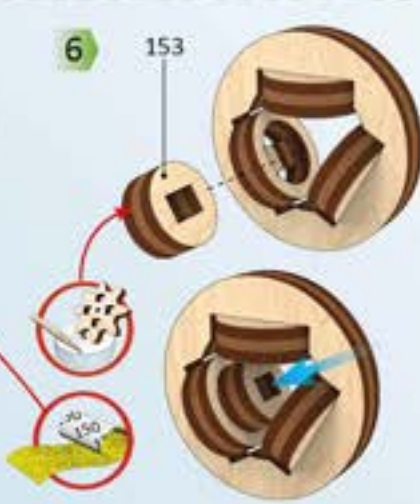

7



x3

8

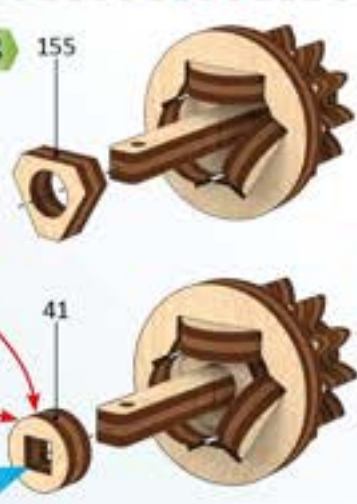

x3



f4



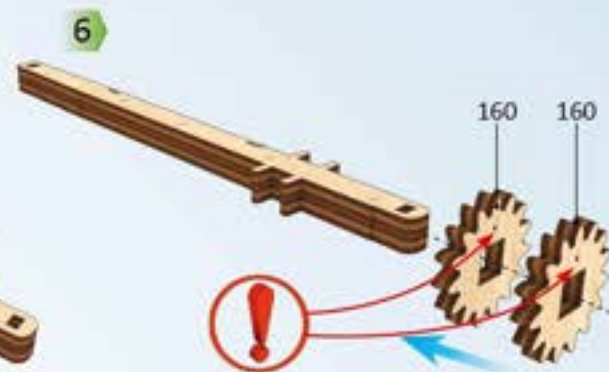
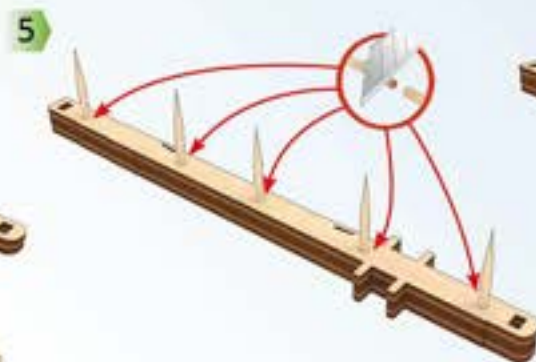
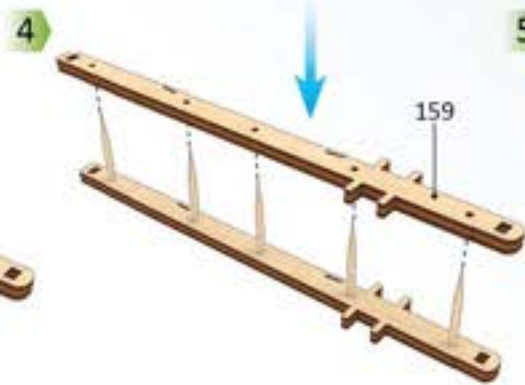
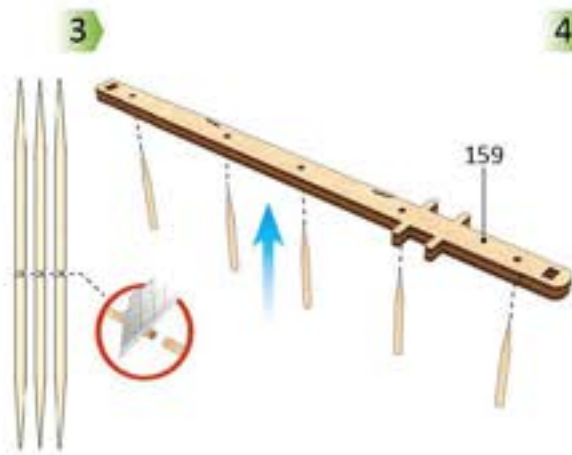
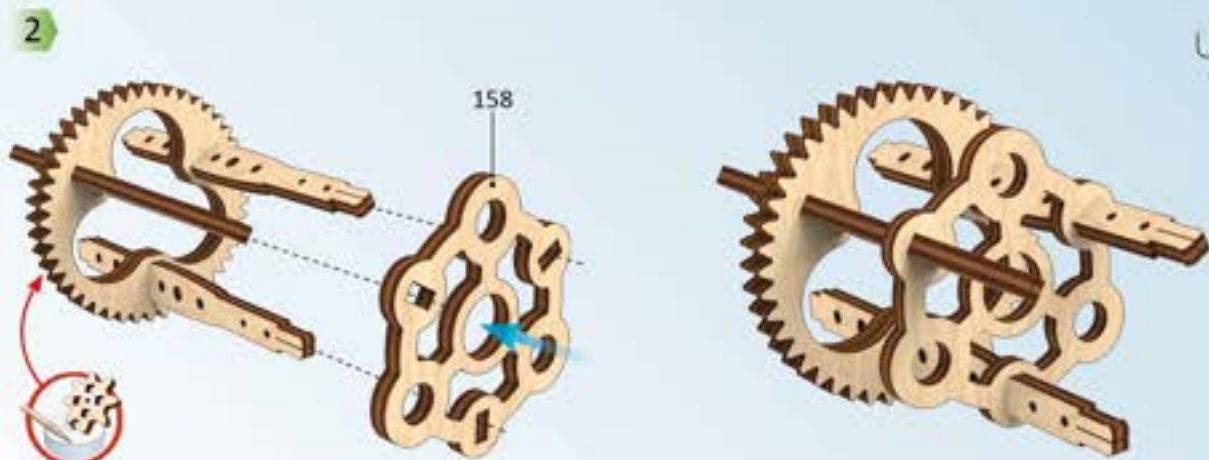
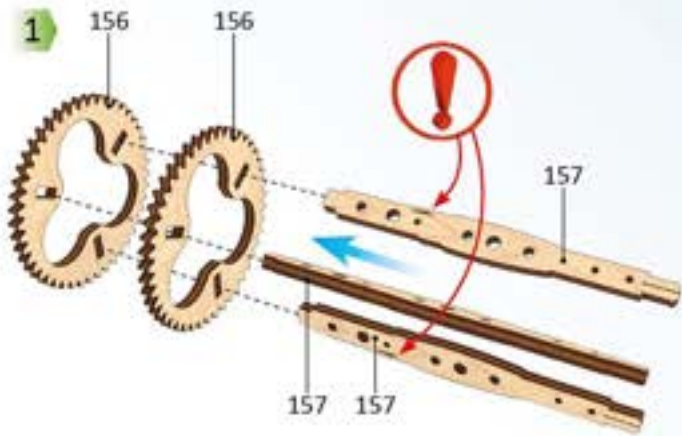



1

1

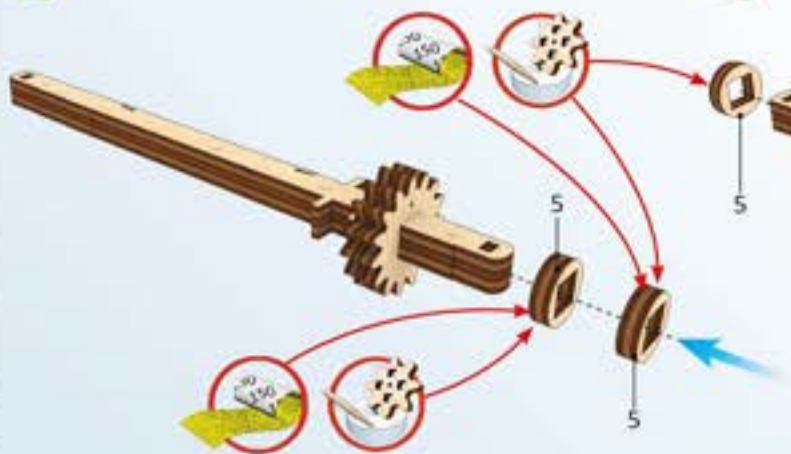

2

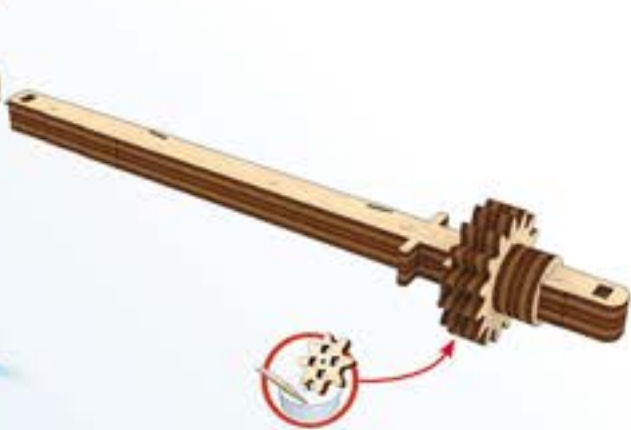

3



3

4

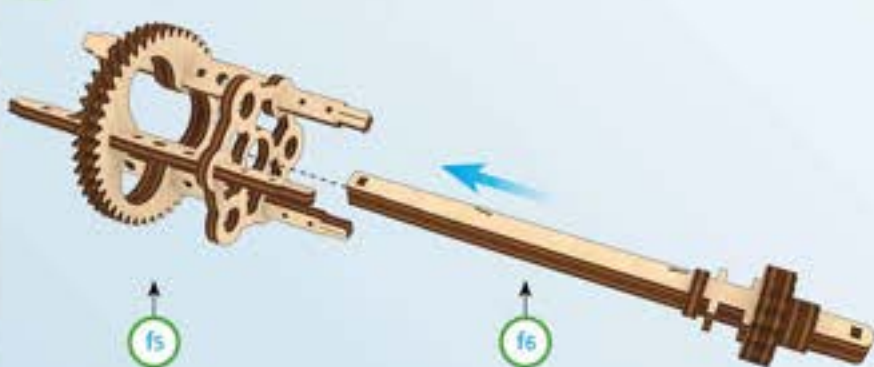

5

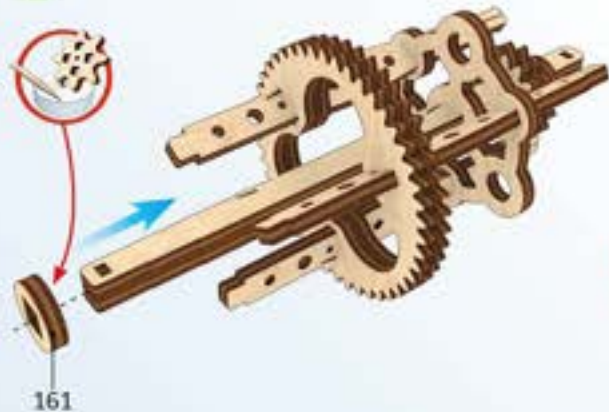

6

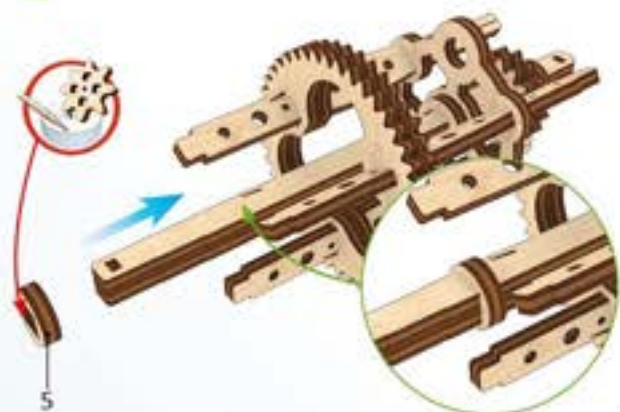



4



5

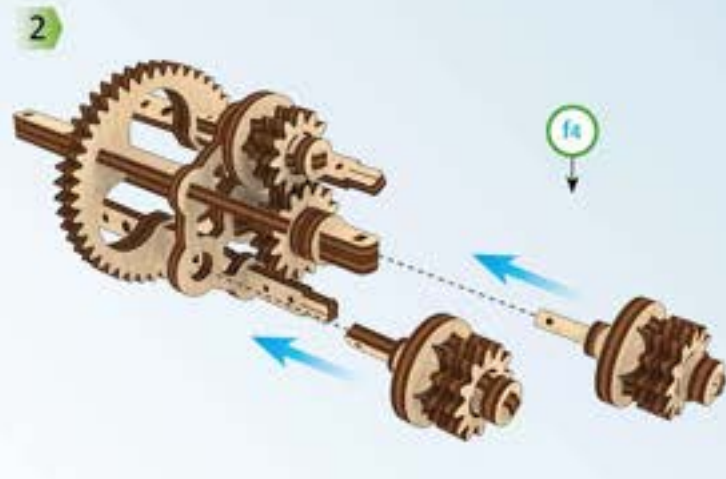
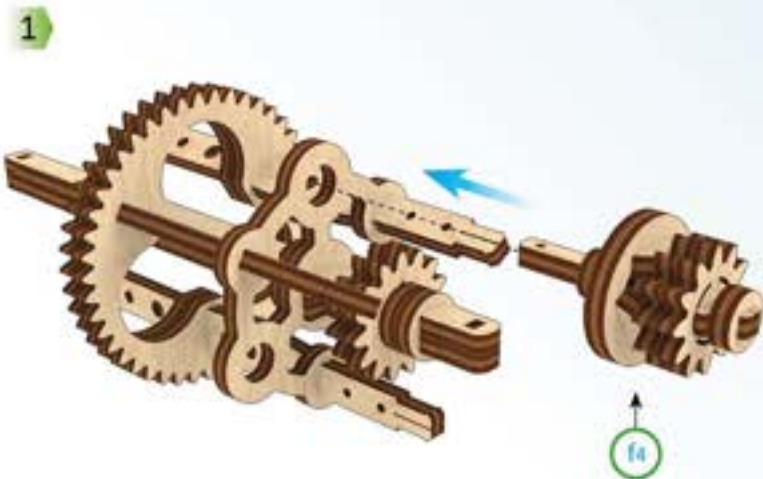

1

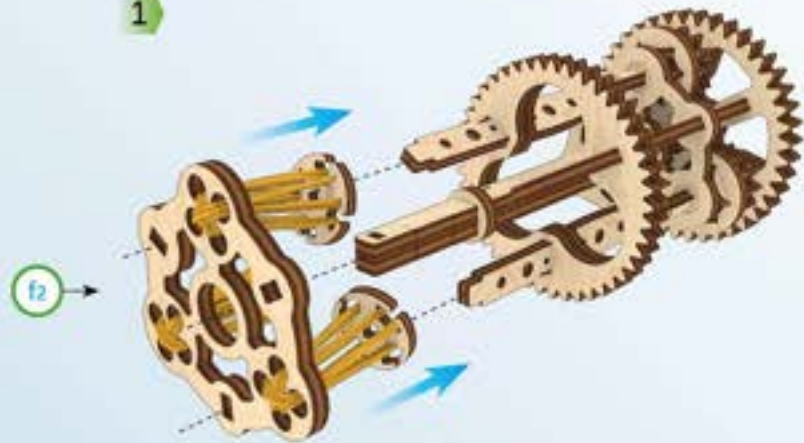

2

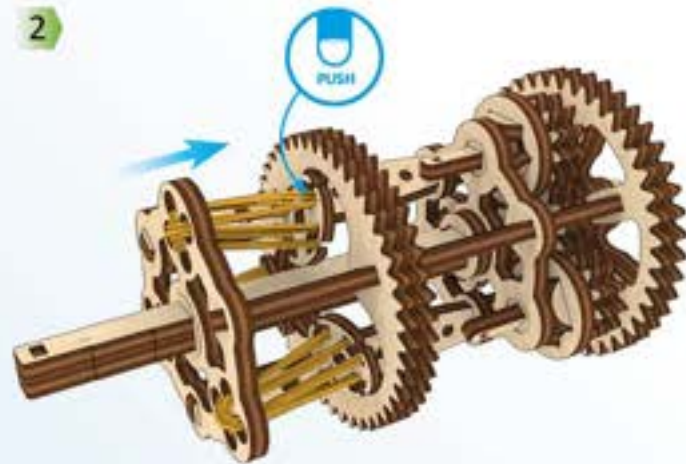

3

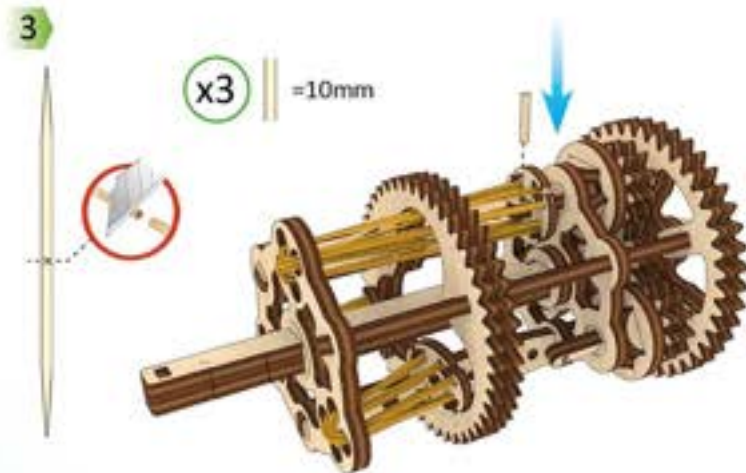

4



5

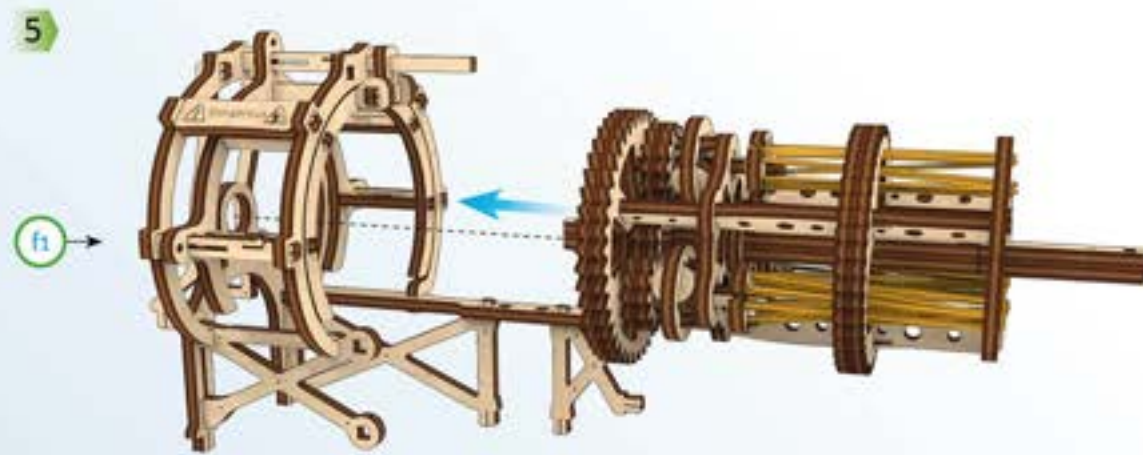



5

1

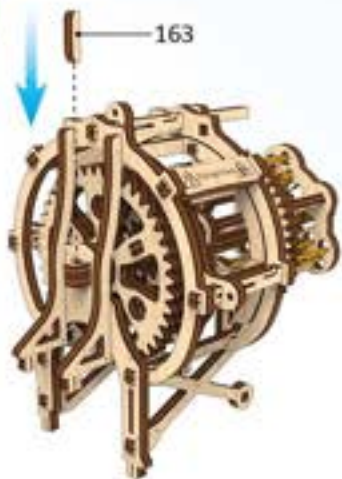

2



6

3

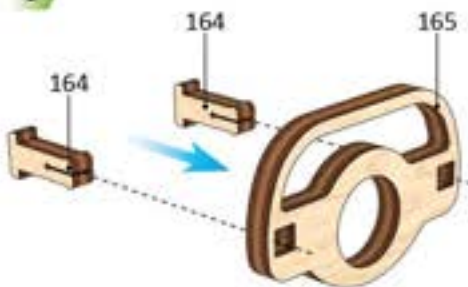

4

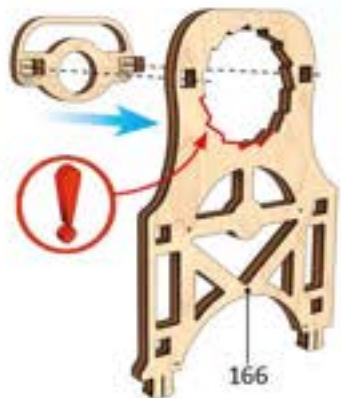

5



6

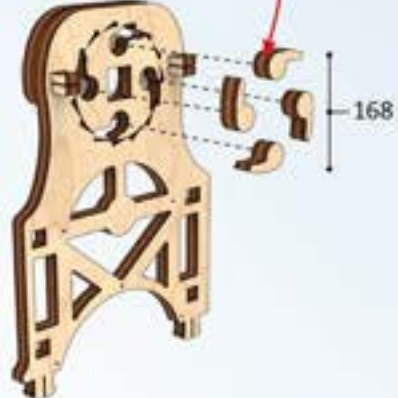

7

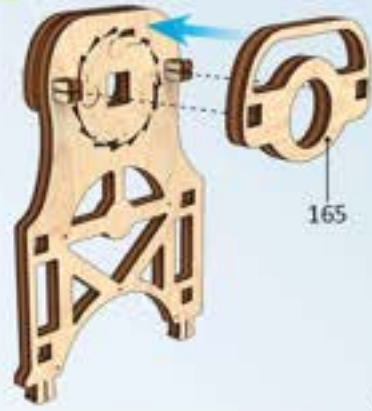



1

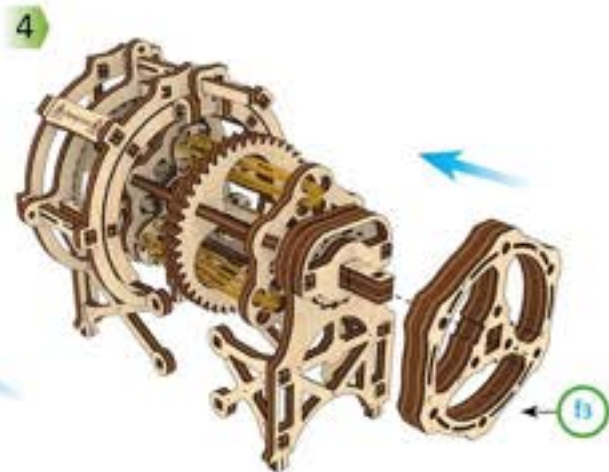
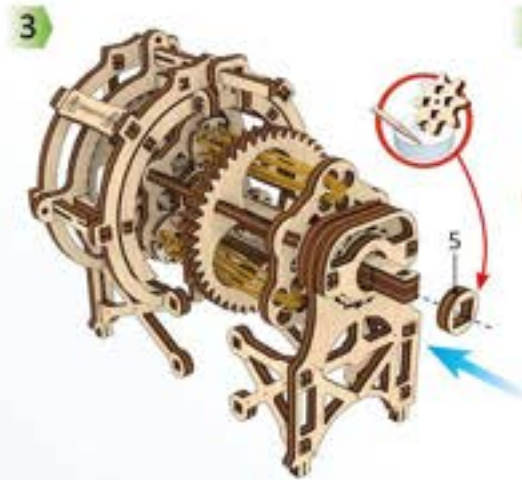
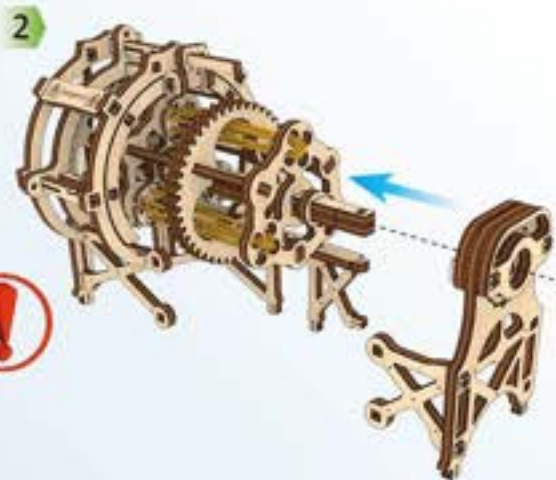
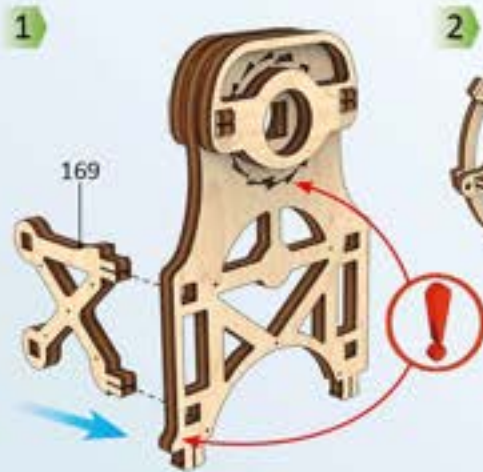

2



3

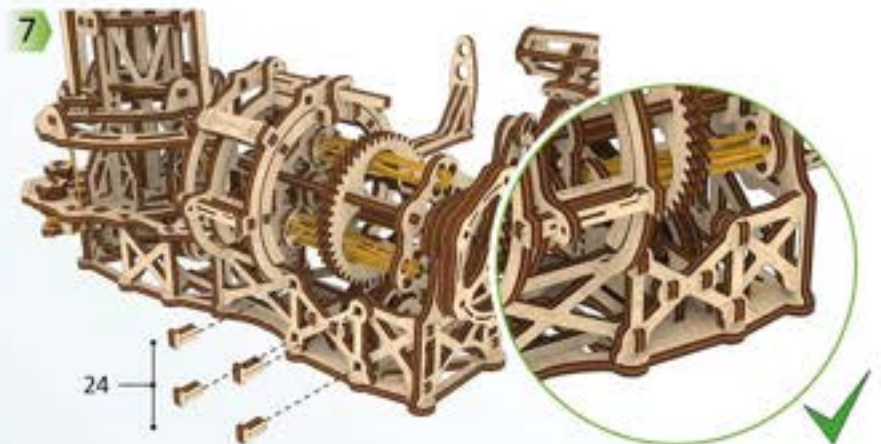
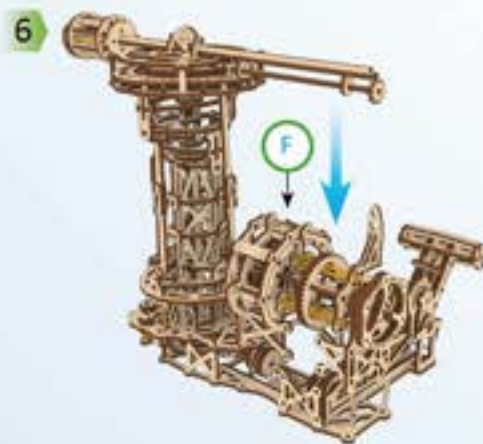
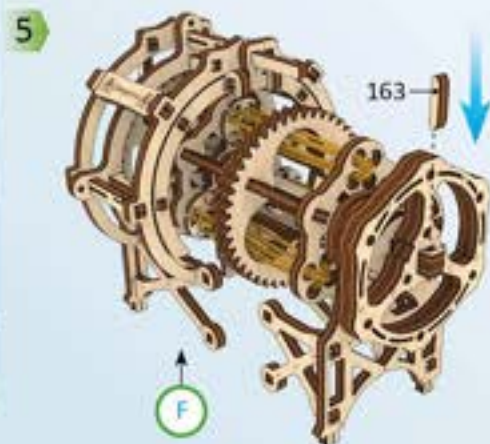



6



7

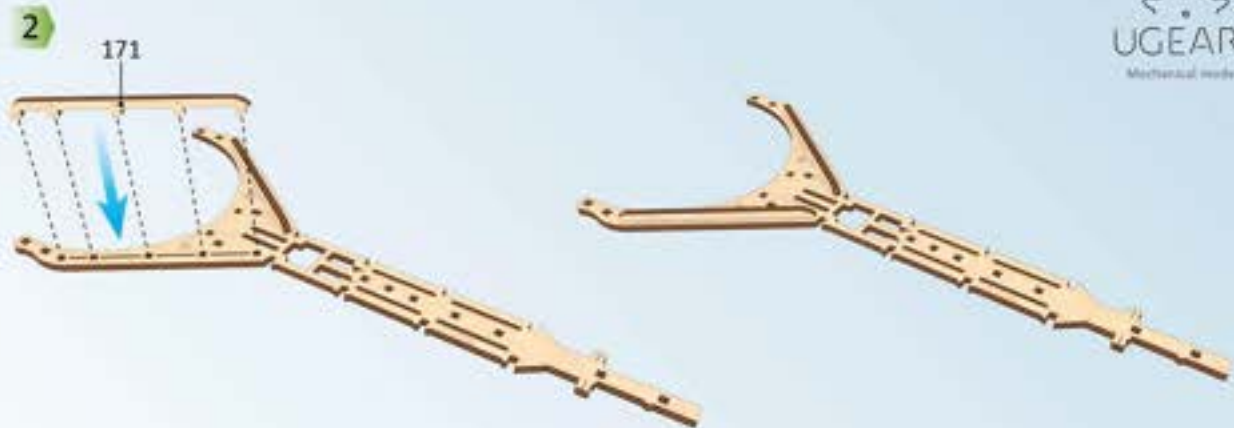
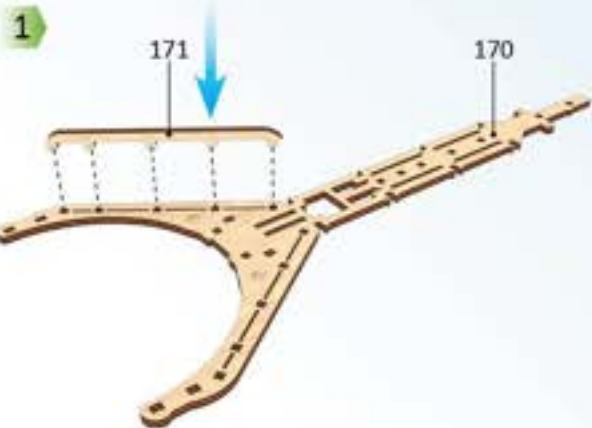

8

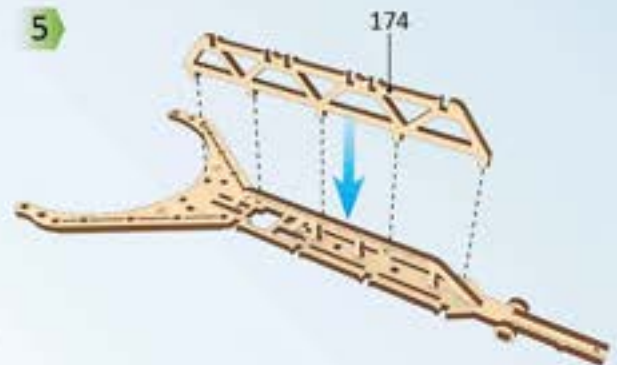
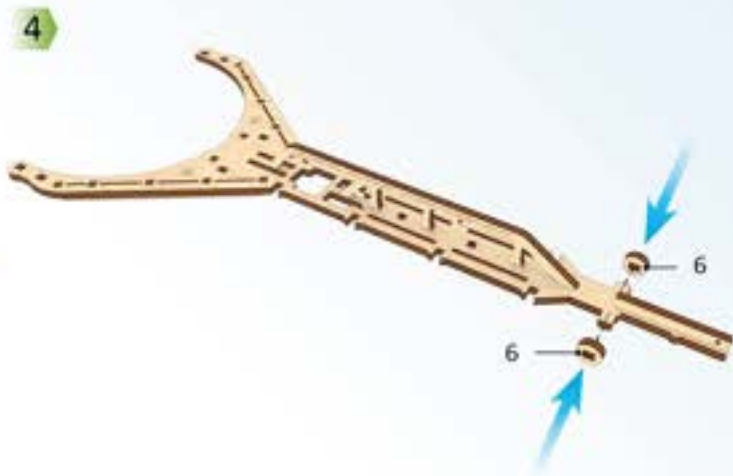
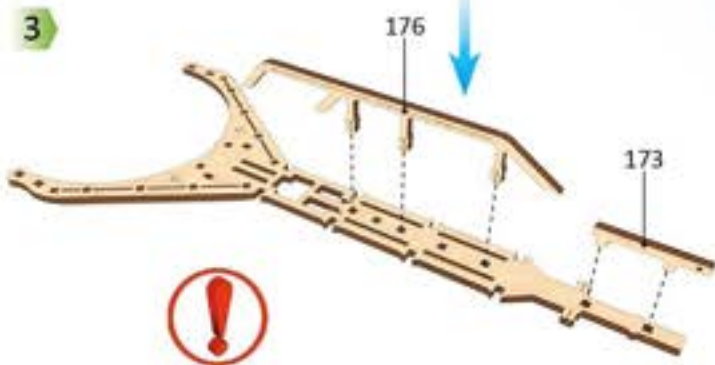



7



8

1

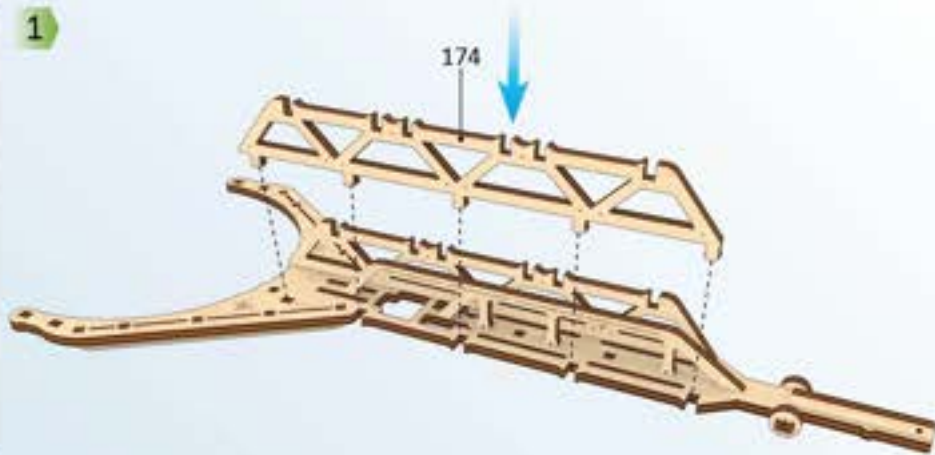

2

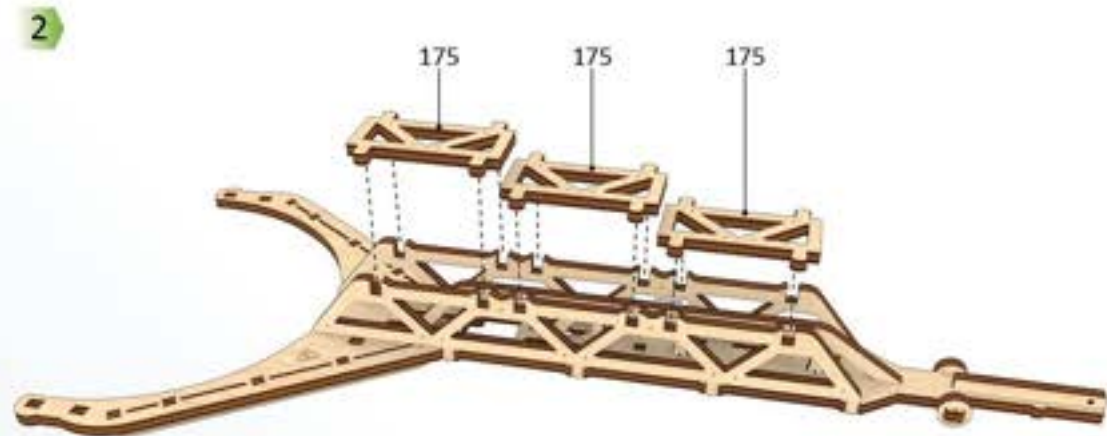

3

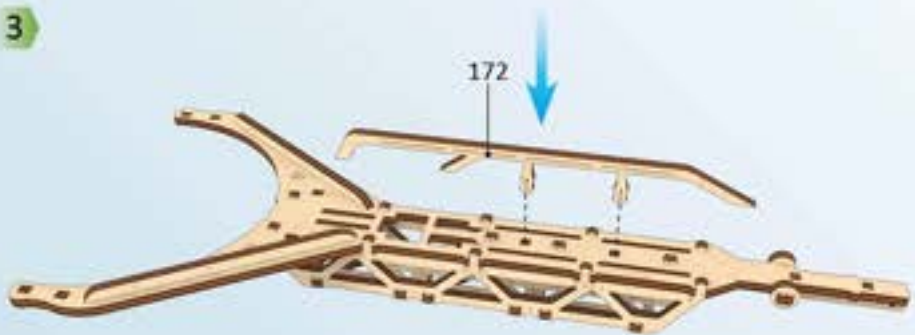

4

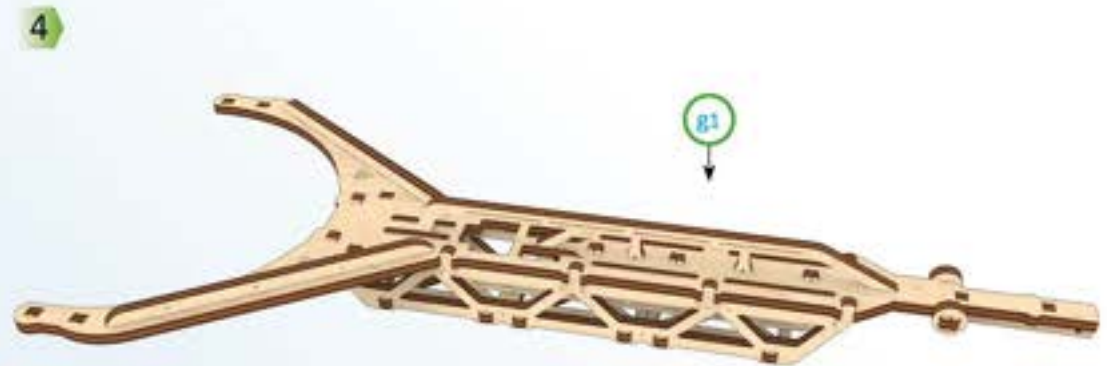



7



8

1

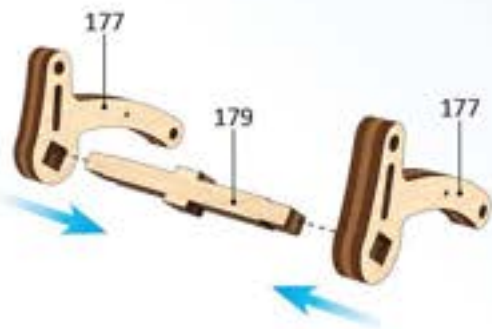

2

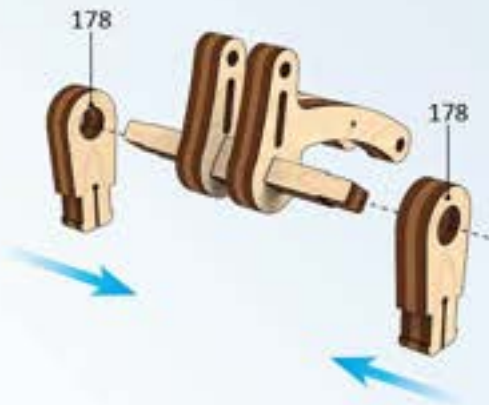

3

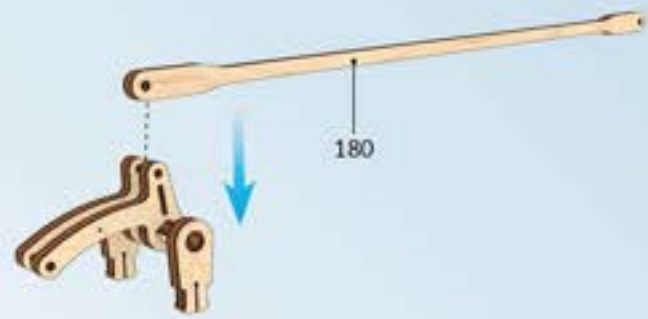

4

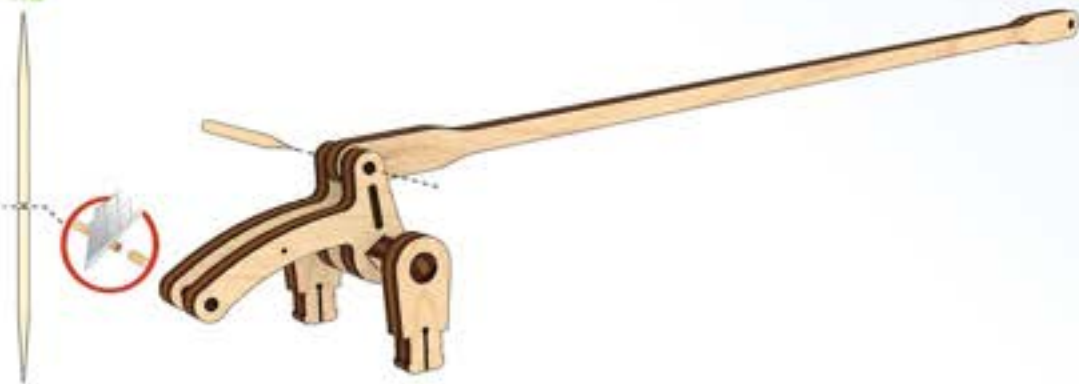

5

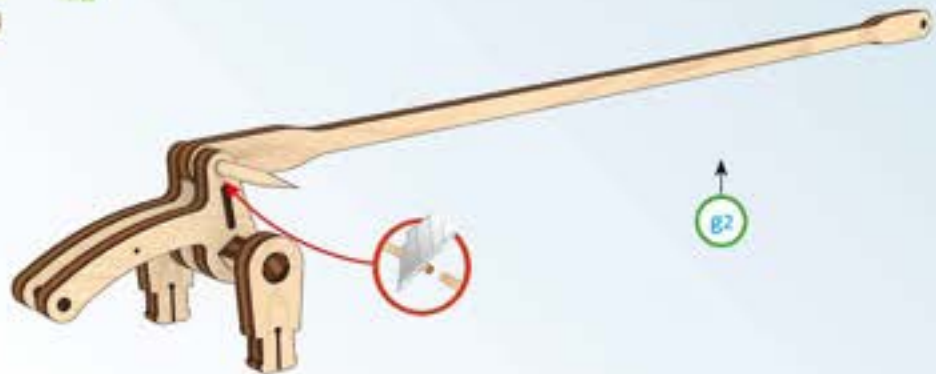

87



7

1



2

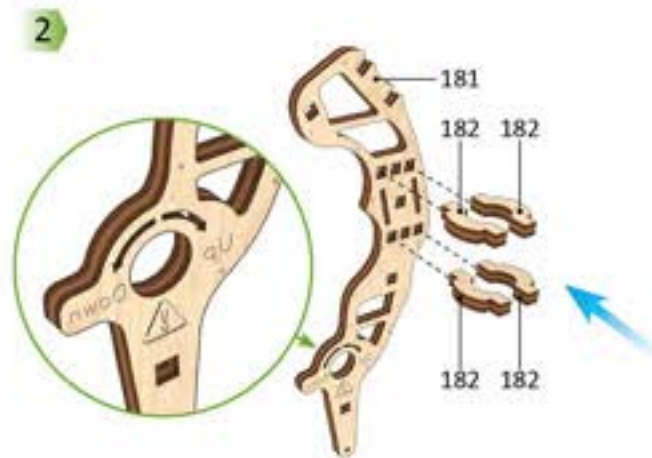

8

3



4



5



6





6

1

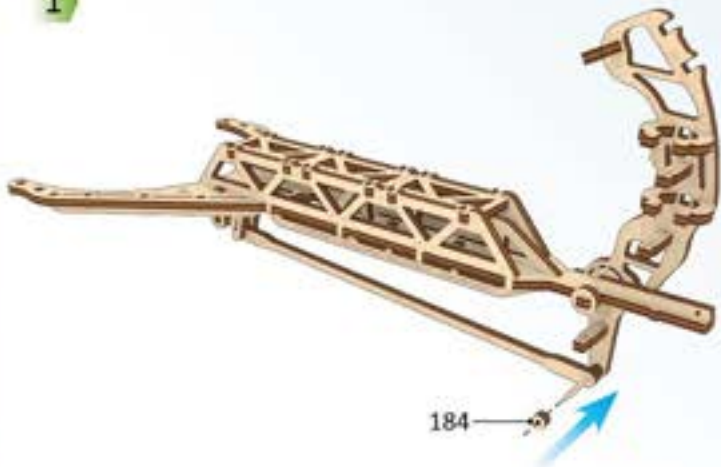

2

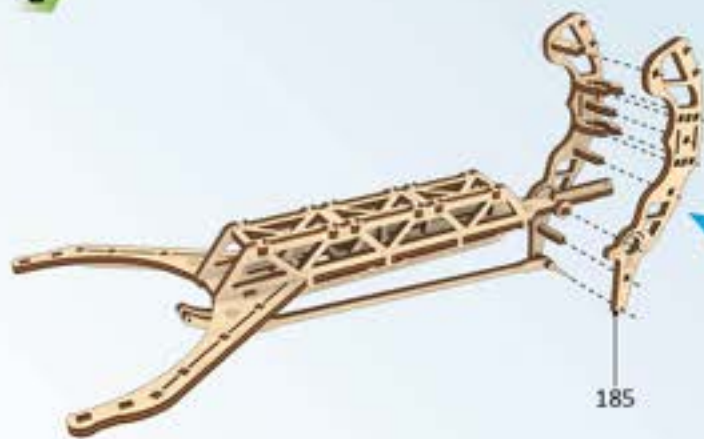

3



8

4

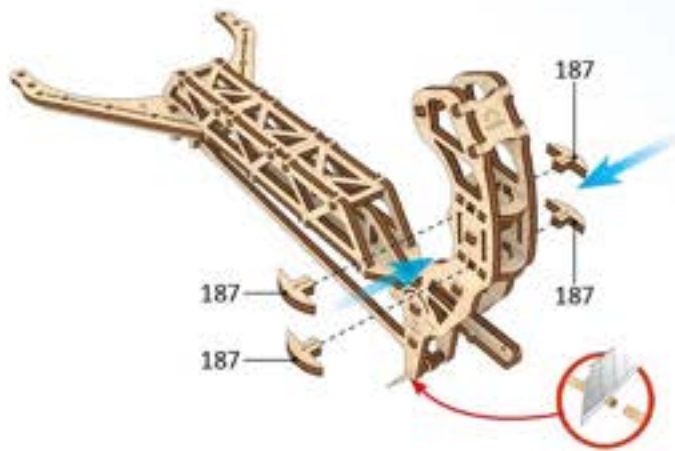

6

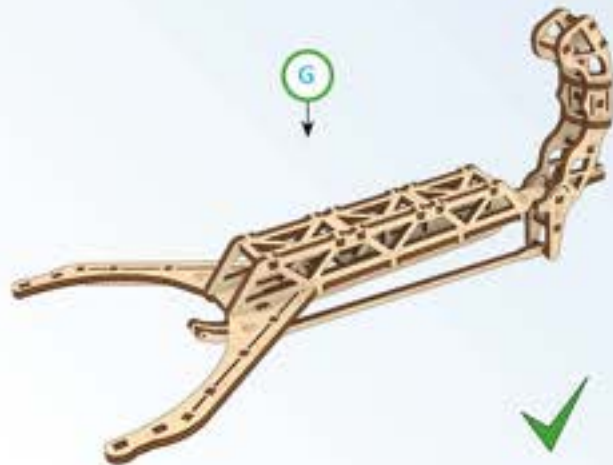



1

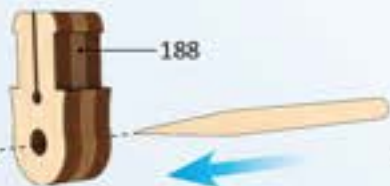

2

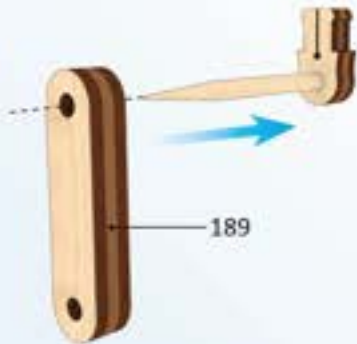

3

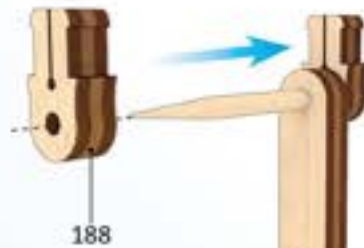

4



5

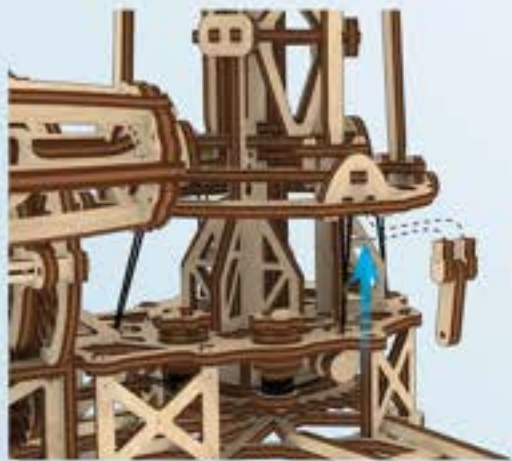

6





1

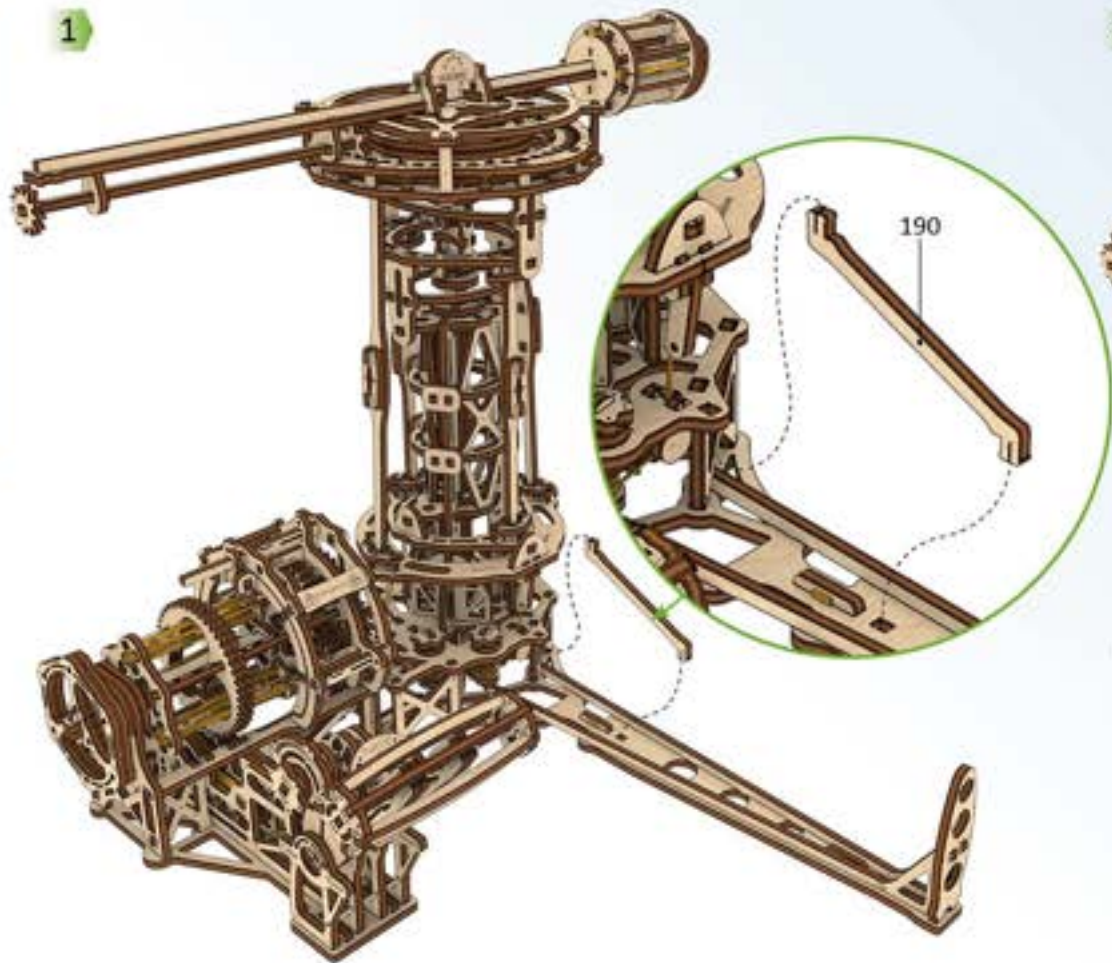

2

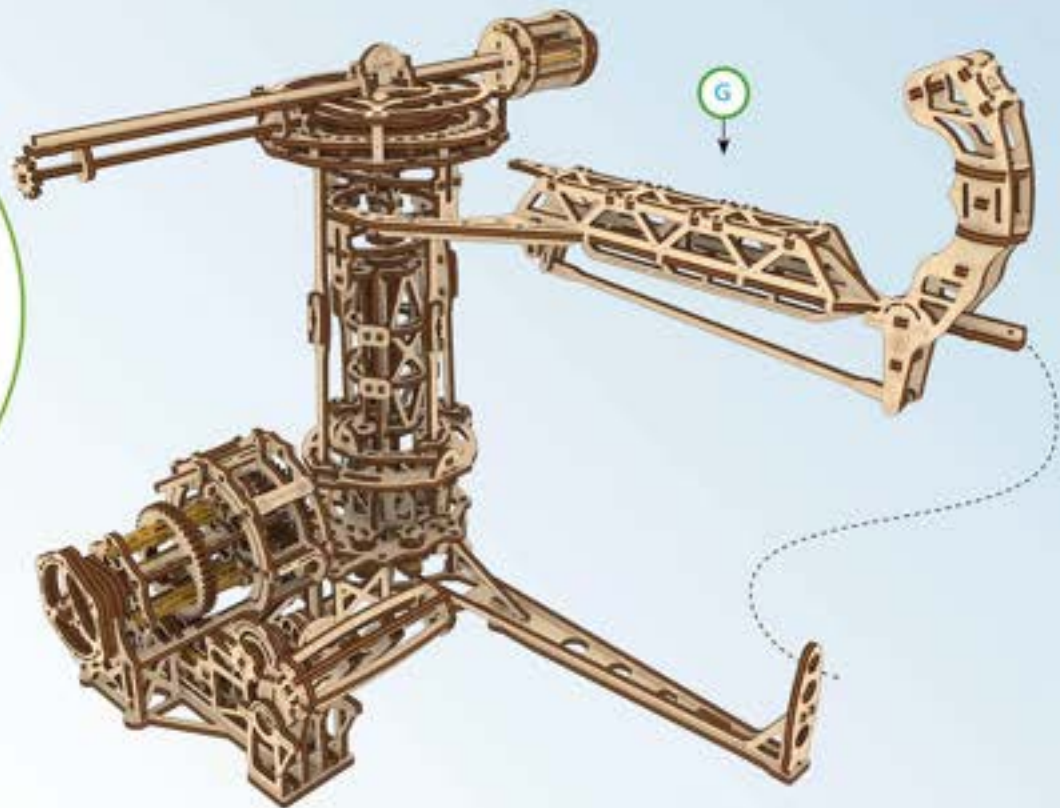



1

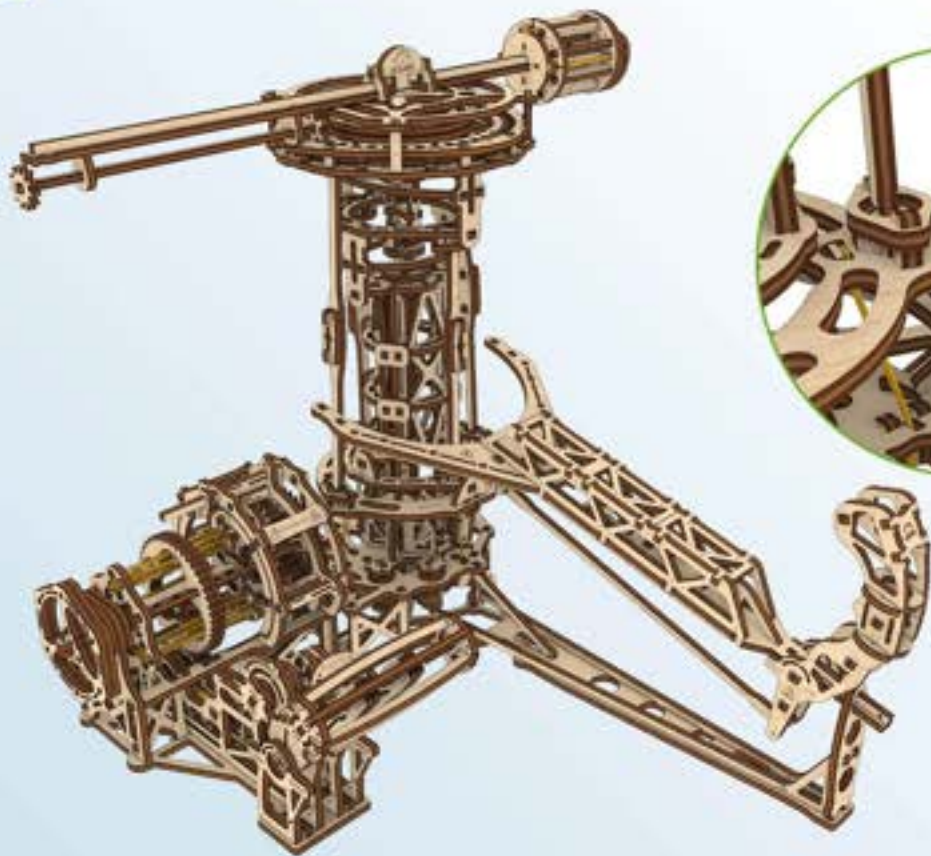

2

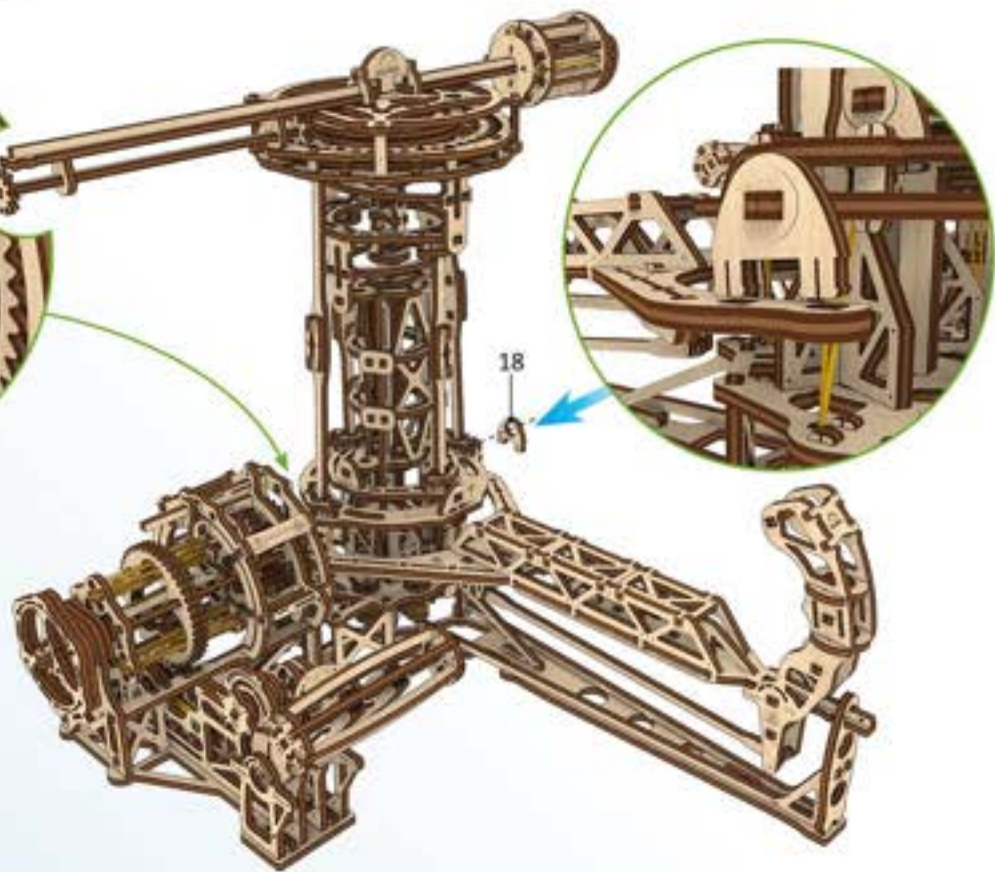

1



2



3

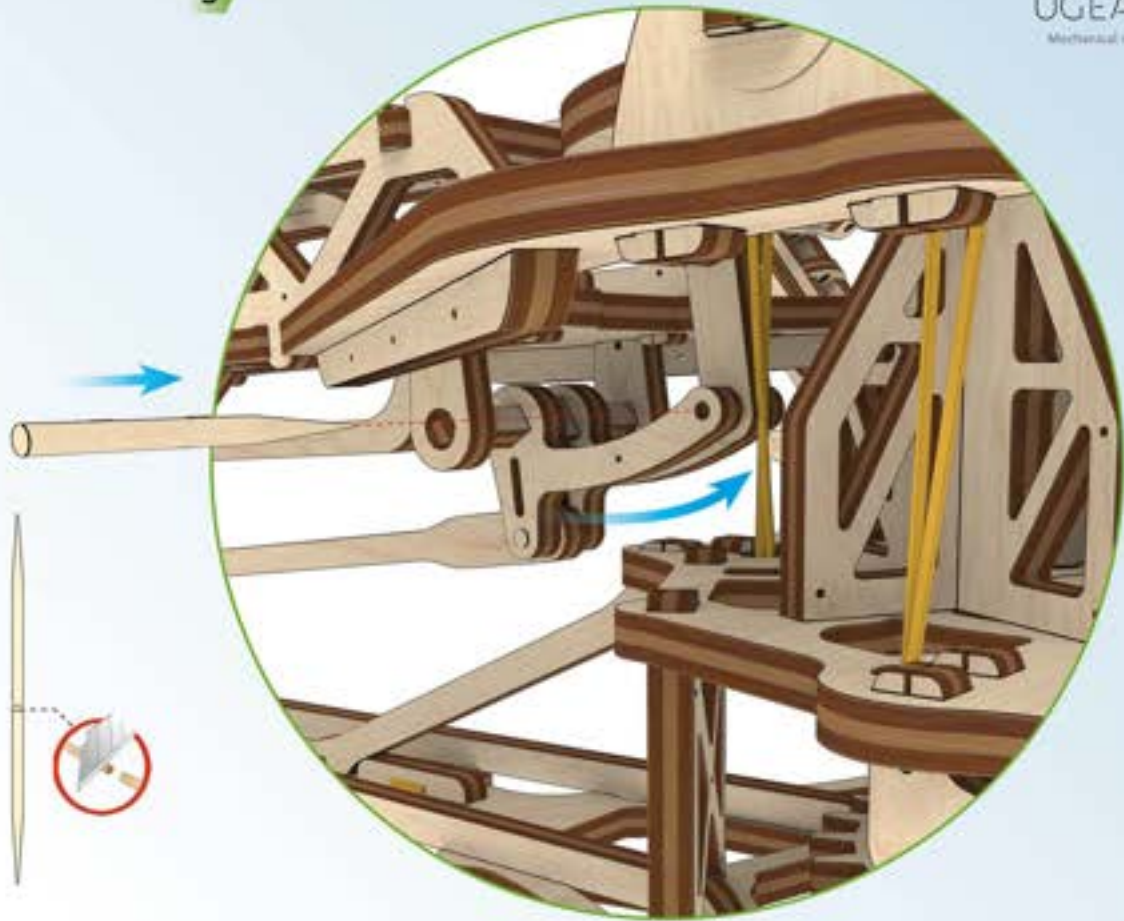

1

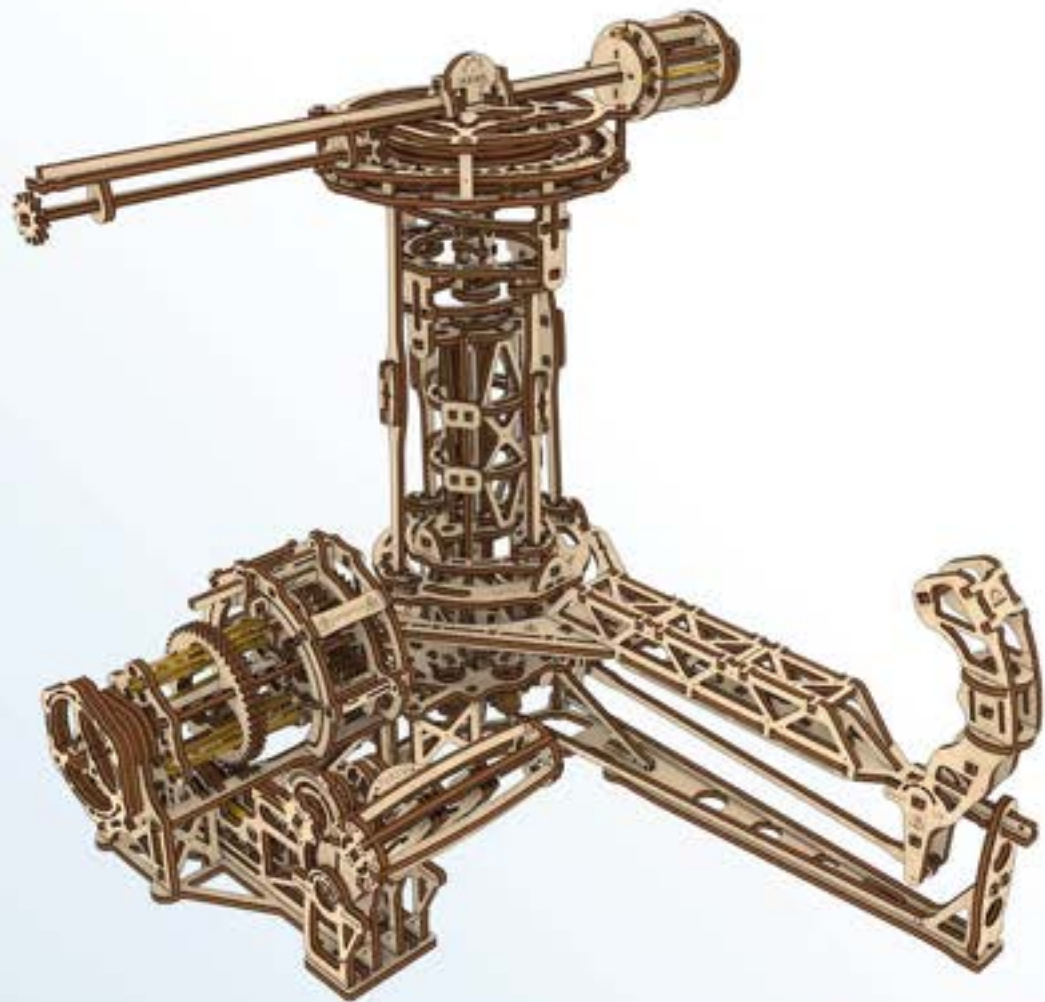

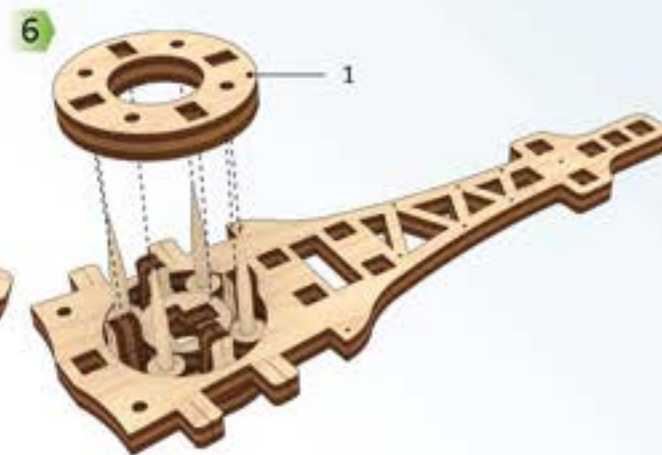
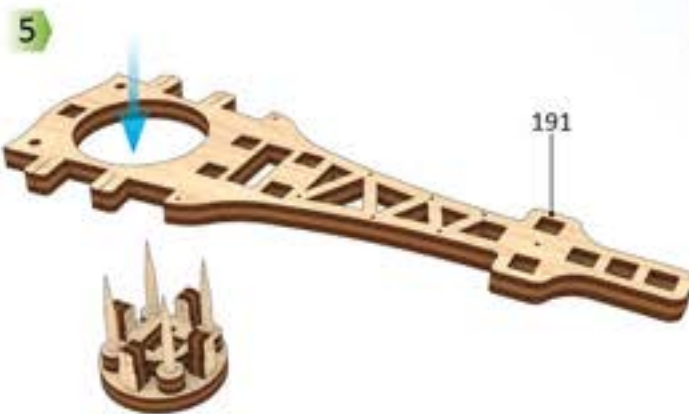
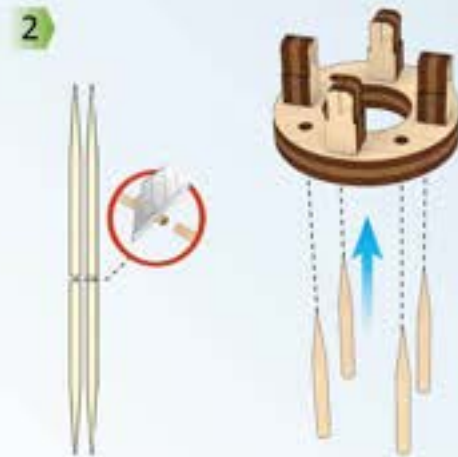
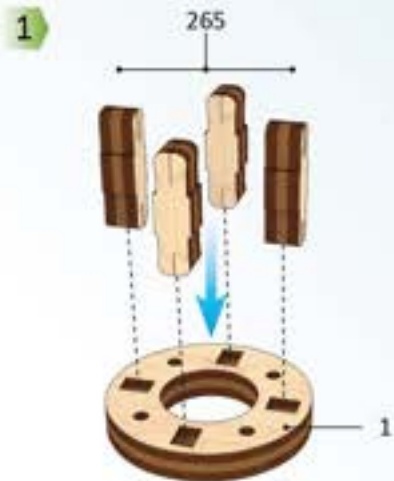



1

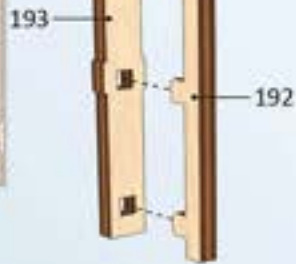

2

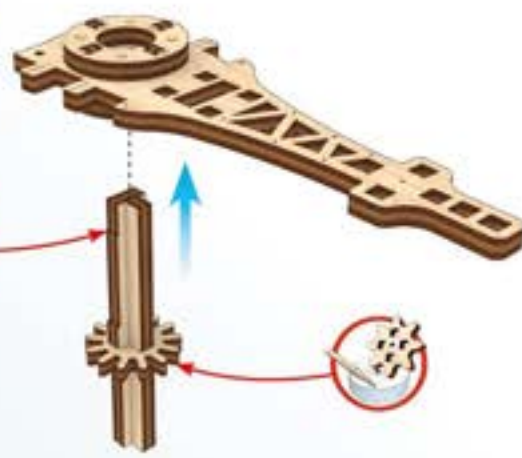

3

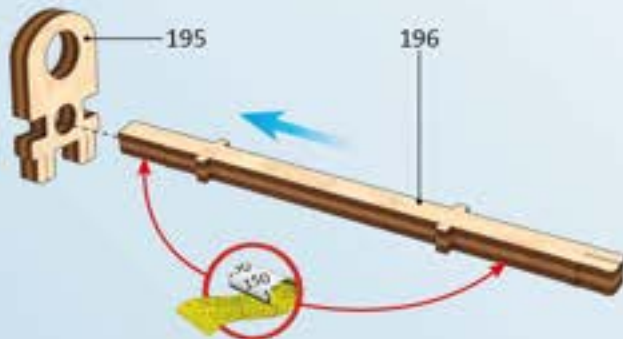

4

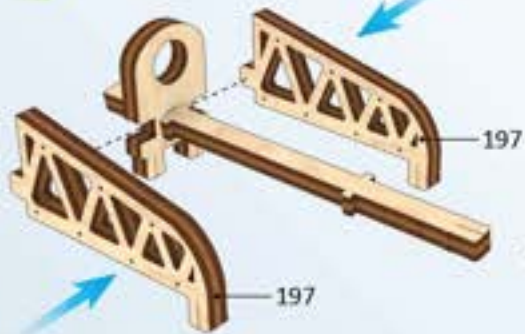

5

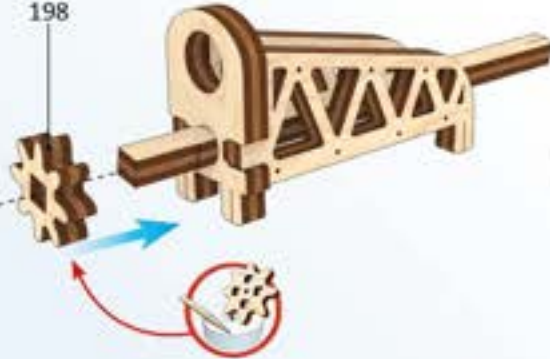



1

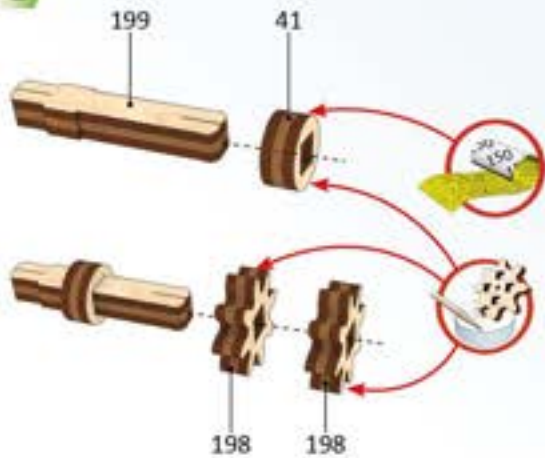

2

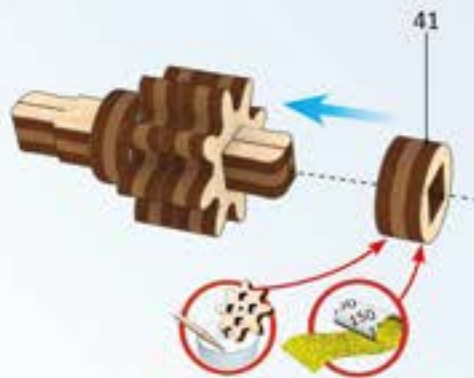

3

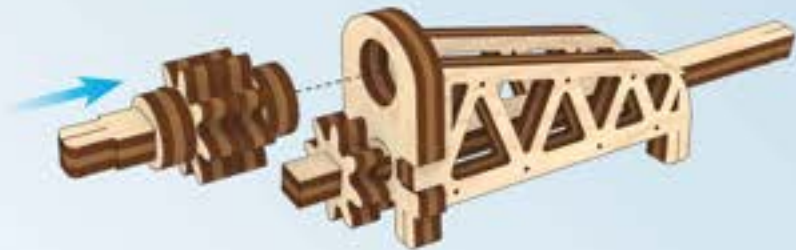

4



5

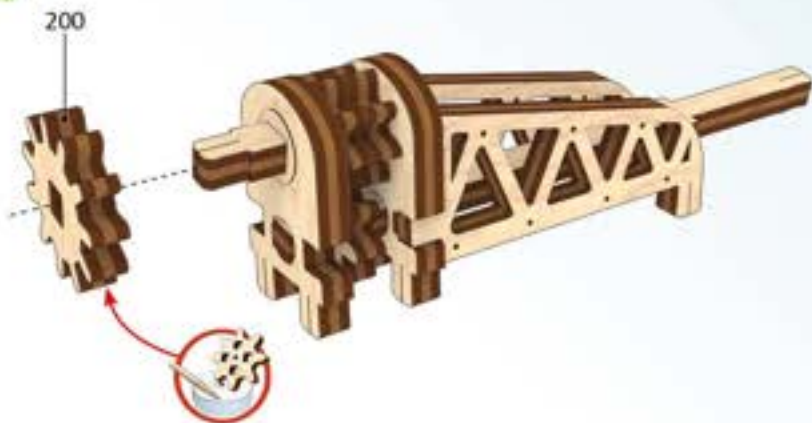

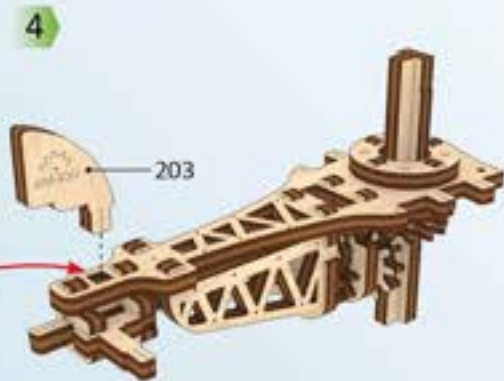
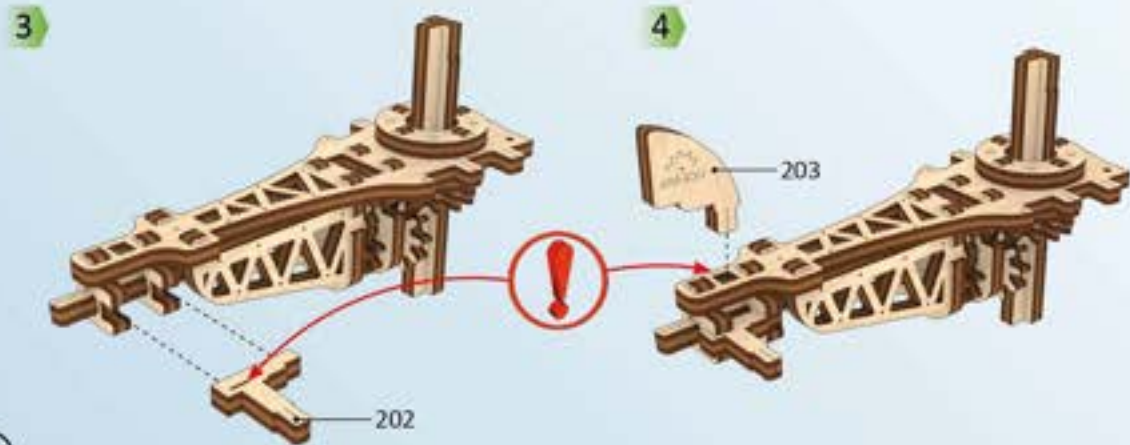
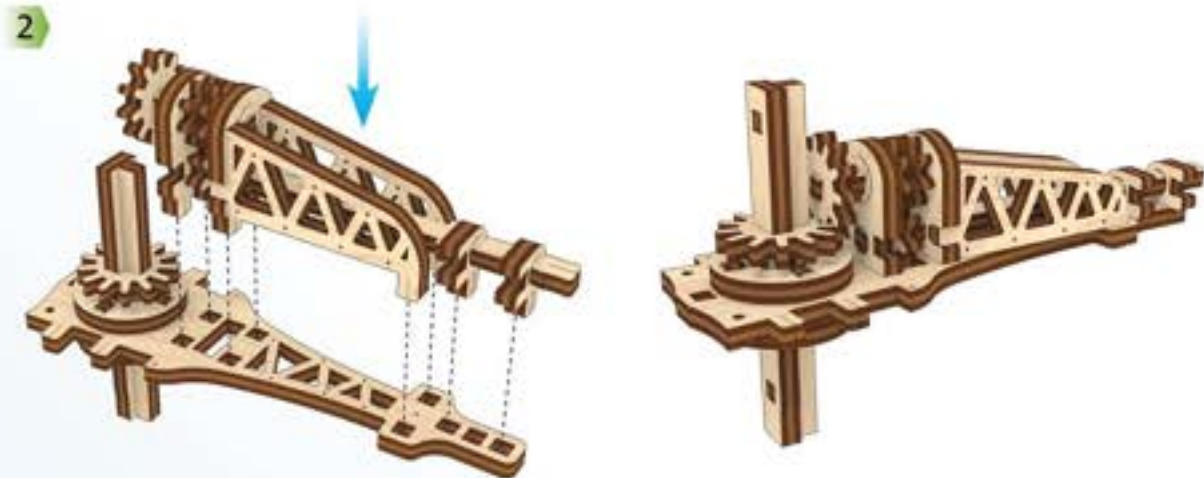
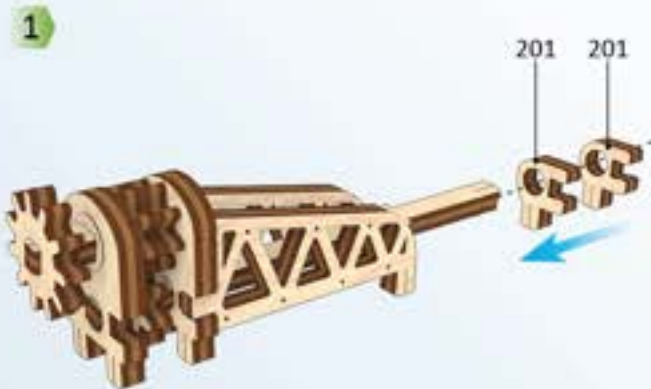

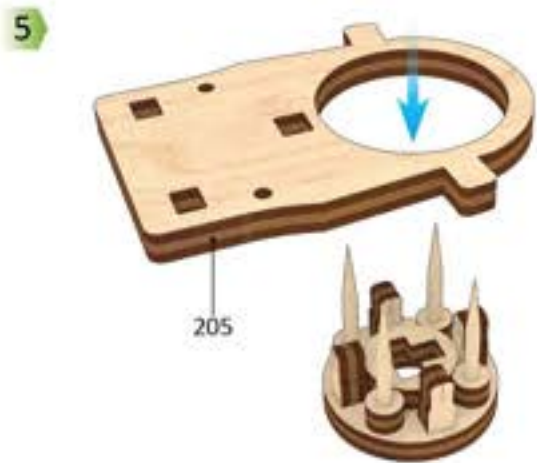
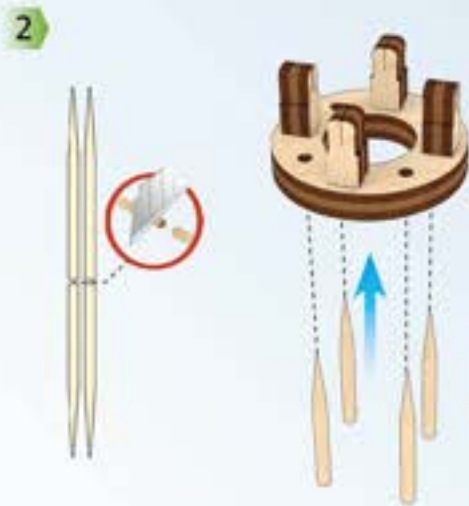

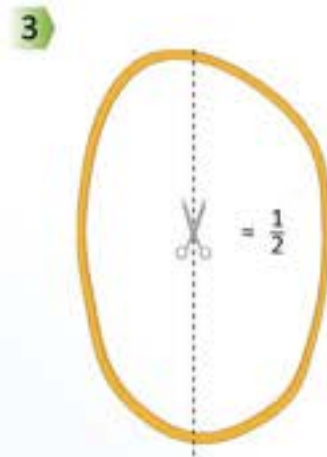
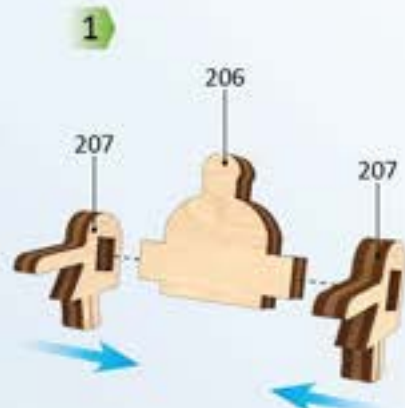



1

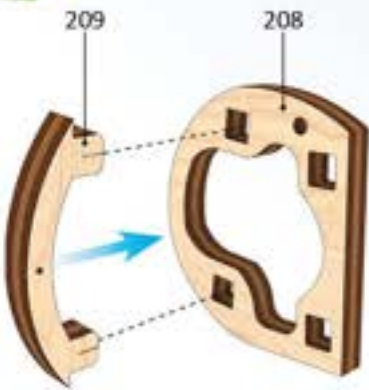

2

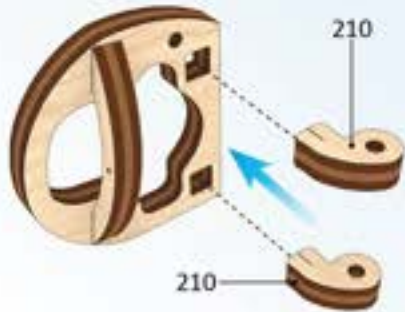

3



4

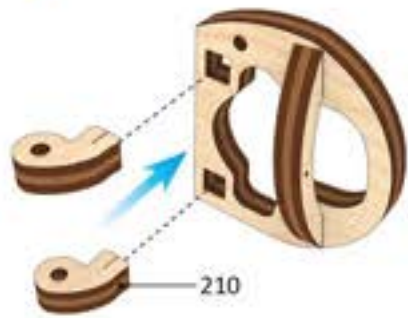

5

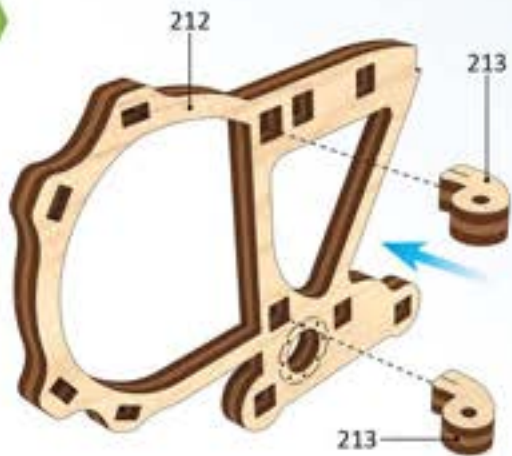

6

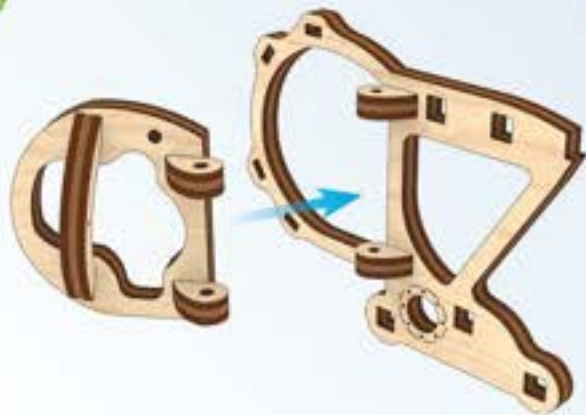

7



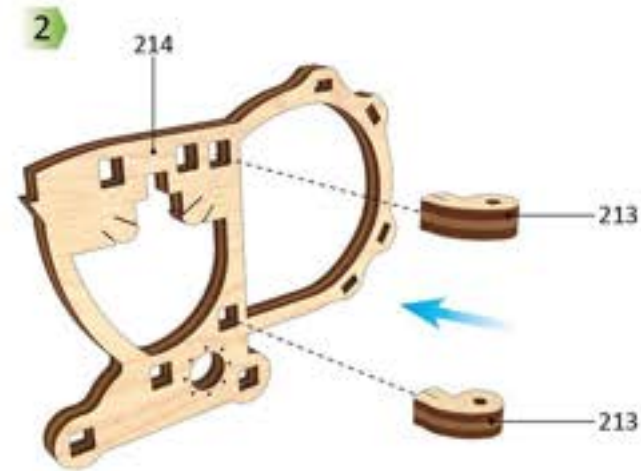
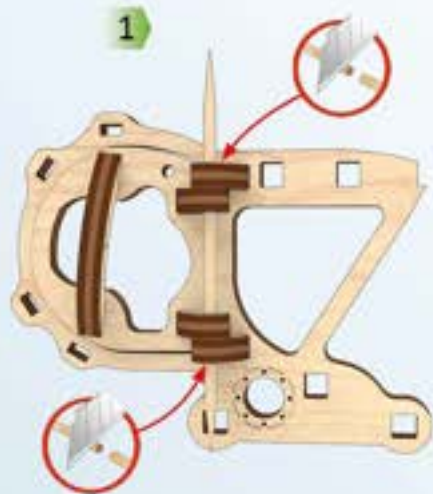



1

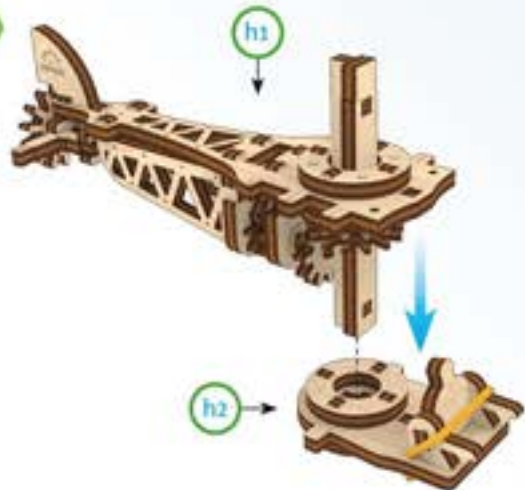

2

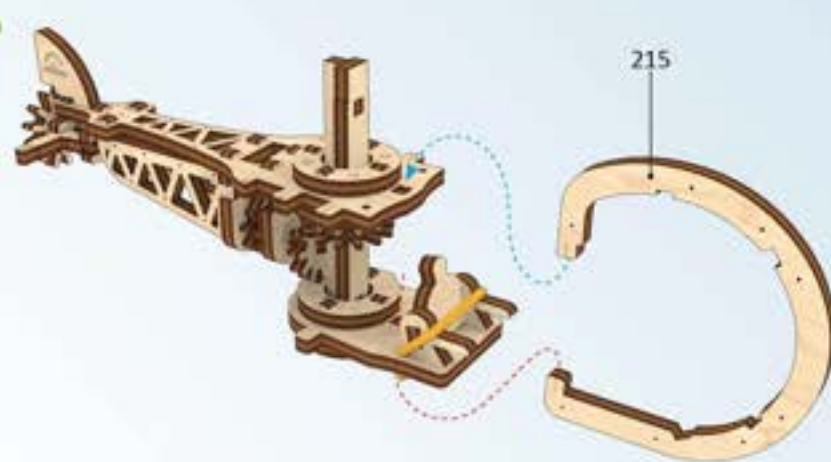

3

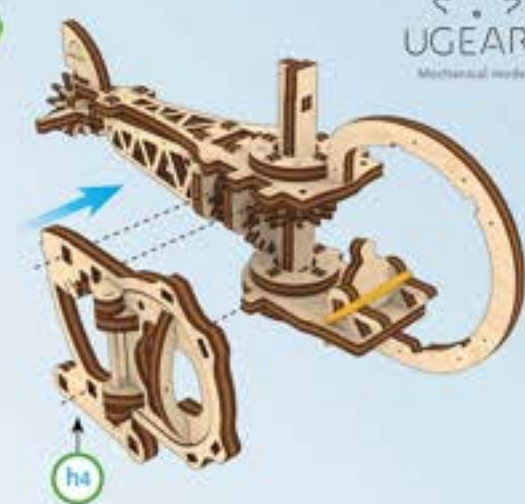

4

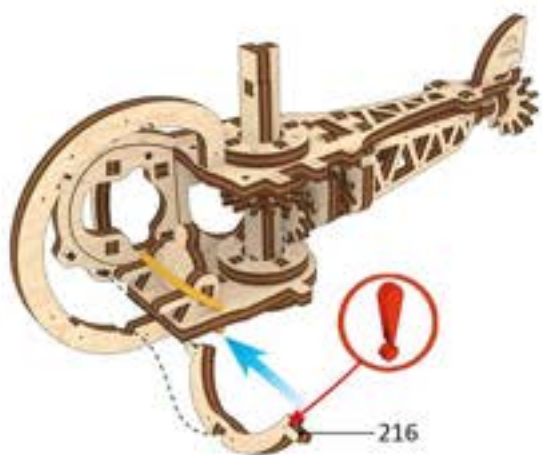

5

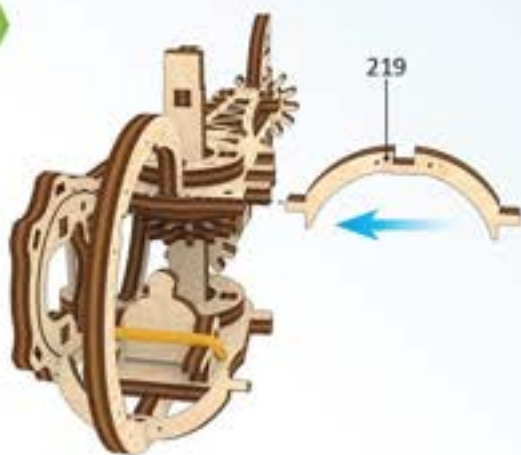

6

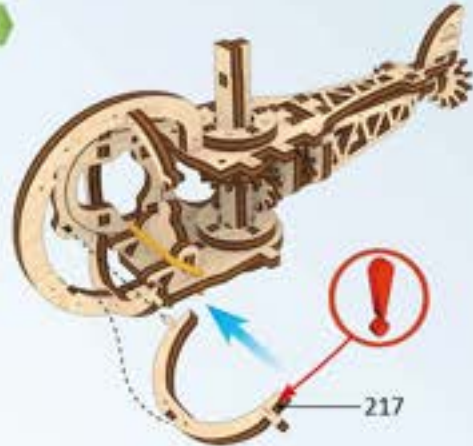

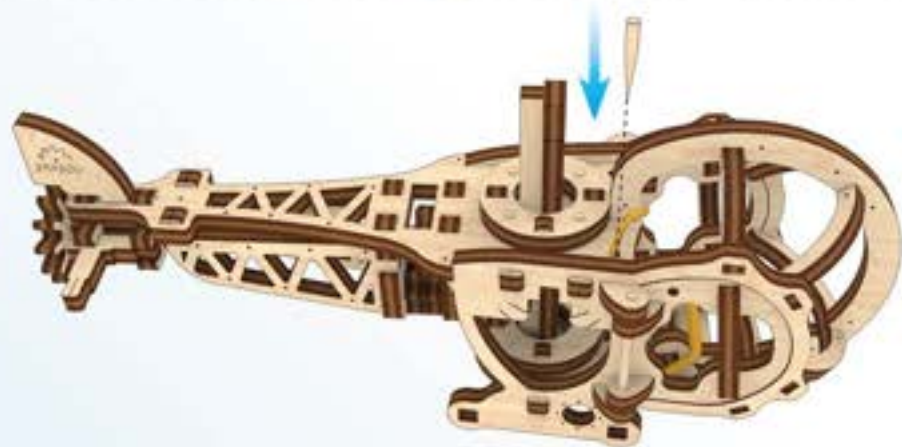
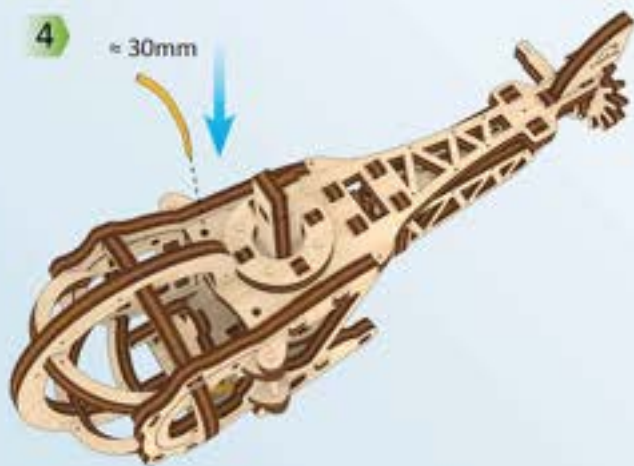
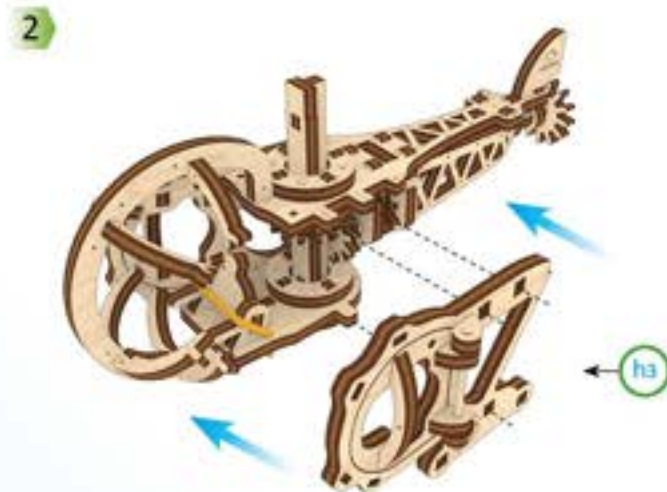

1



2



3



4



5



6



7

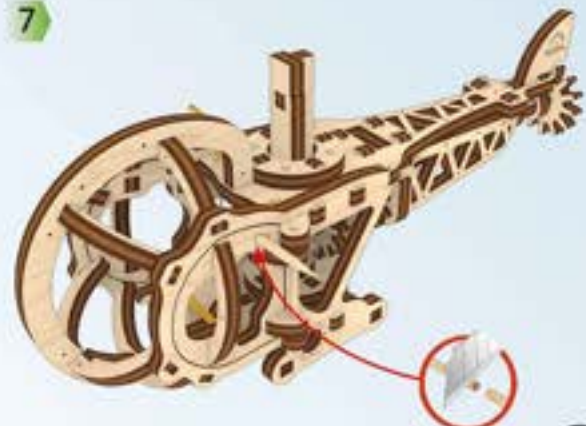



20



20

1

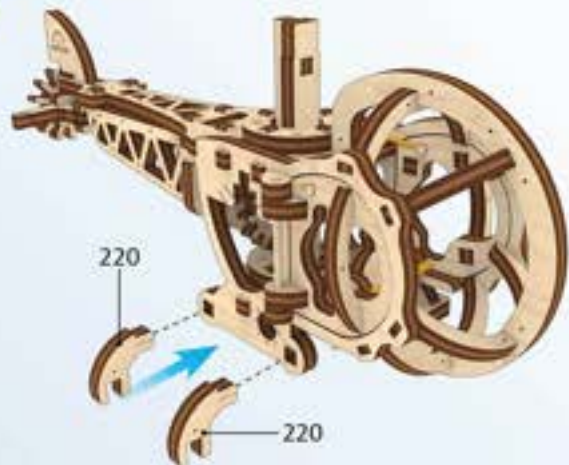

220

220

2

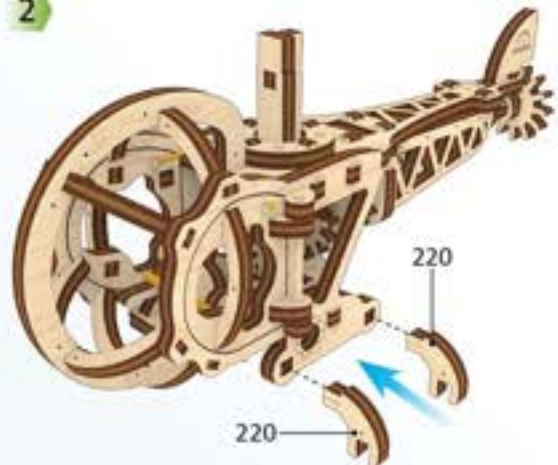

220

220

3

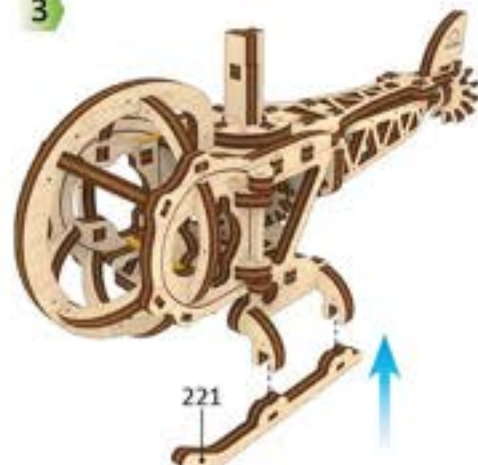

221



20

4

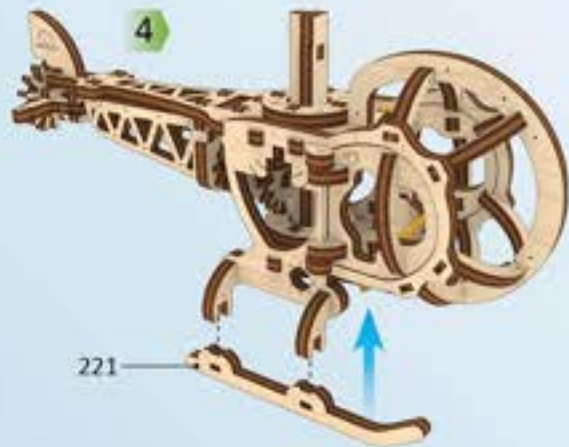

221

5

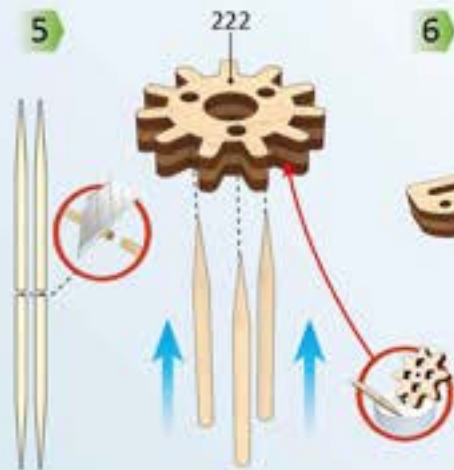

222

6



223

7



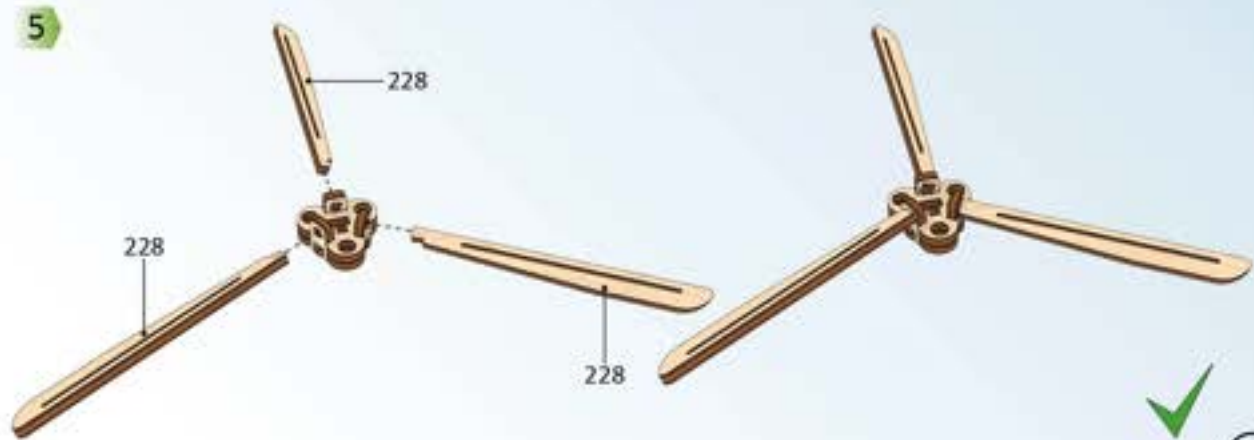
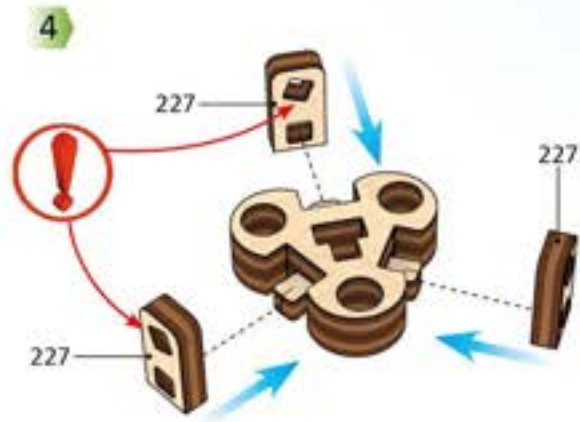
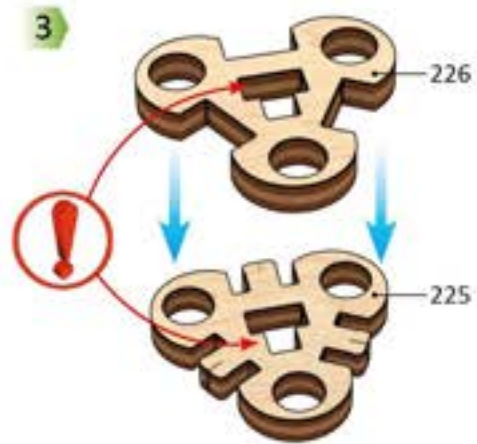
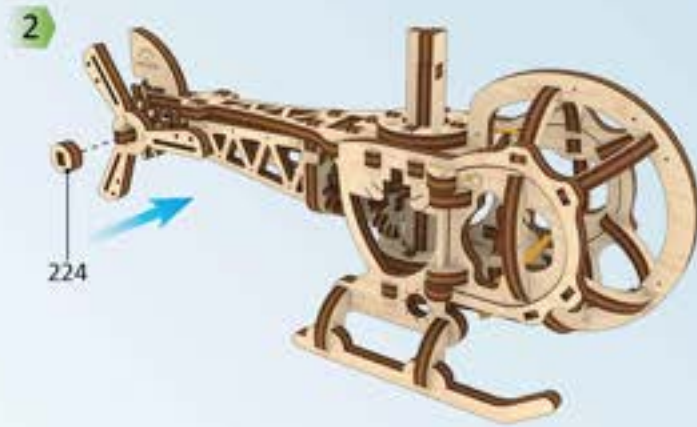
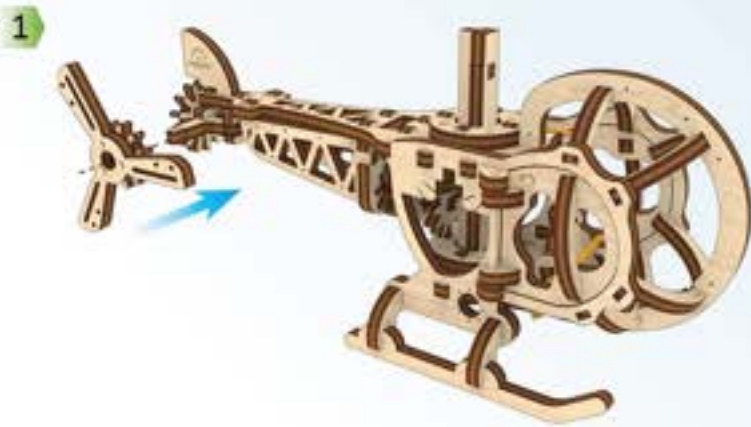

1



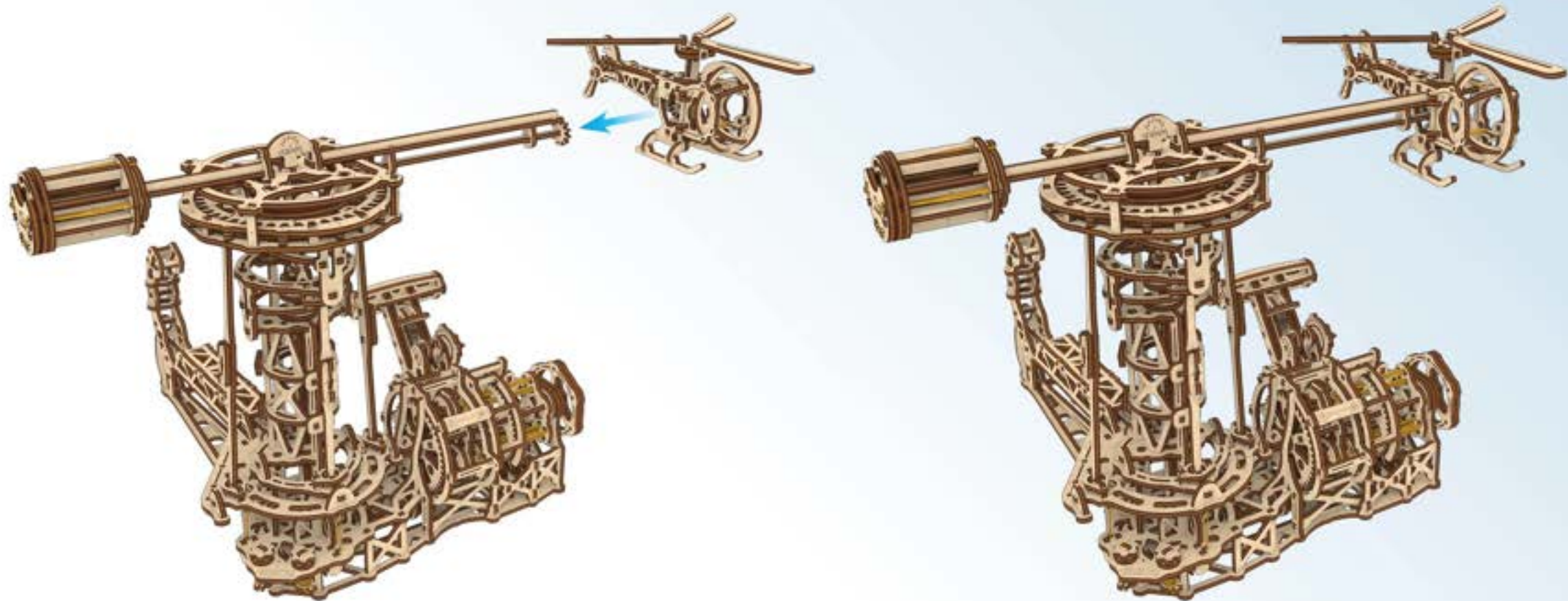

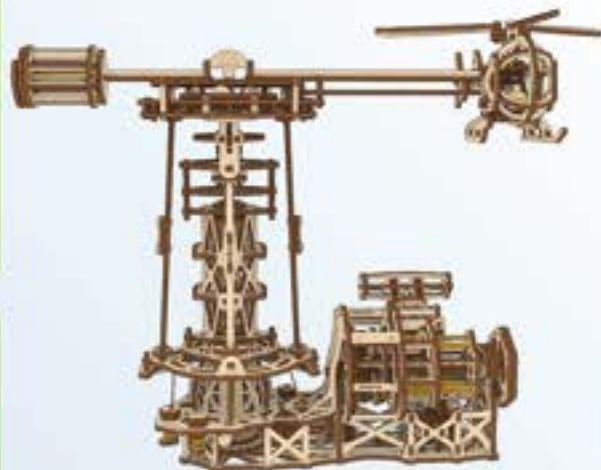

**ENG** Adjustment of the counterweight mechanism.

After assembling the whole model, fix the helicopter on the bar and add coins of the maximum available diameter to the «mechanism-holder» until the bar assumes a horizontal position. After this, fix the retainer.

**UKR** Налаштування механізму протизваги.

Після складання всієї моделі закріпити вертоліт на штанзі і додавати в «механізм-обойму» монети максимального наявного діаметра до тих пір, поки штанга не прийме горизонтальне положення. Після цього встановити фіксатор.

**DEU** Justieren des Ausgleichsgewichts.

Nachdem das ganze Modell zusammengebaut wurde, wird der Helicopter an der Querstrebe befestigt. Danach werden die Münzen als Gegengewicht in den dafür vorgesehenen Schlitz gesteckt, bis die Strebe eine horizontale Position erreicht hat und mit der Halterung befestigt.

**FRA** Ajustement du mécanisme de contrepoids.

Après avoir assemblé le modèle, fixez l'hélicoptère sur la barre et ajoutez des pièces de monnaie d'un diamètre correspondant jusqu'à ce que la barre prenne une position horizontale. Après cela, fixez le dispositif de retenue.

**POL** Ustawienie mechanizmu przeciwwagi.

Po zmontowaniu całego modelu przymocuj śmigłowiec do drążka i dodaj do «mechanizmu przeciwwagi» monety o maksymalnej dostępnej średnicy, aż drążek uzyska pozycję poziomą. Następnie należy ustawić blokator.

**SPA** Ajuste del mecanismo de contrapeso.

Tras montar el modelo completo, fija el helicóptero en la barra y añade monedas del máximo diámetro posible en el «mecanismo de sujeción», hasta que la barra tome posición horizontal. Después, fija el enganche.

**ITA** Regolazione del meccanismo di contrappeso.

Dopo aver montato l'intero modello, sistema l'elicottero sulla barra e aggiungi i gettoni col diametro più grande al «meccanismo di sostegno» finché la barra assume una posizione orizzontale. Dopodiché sistema il gancio.

**TUR** Ağırlık dengeleme mekanizmasının ayarlanması:

Modelin montajını tamamladıktan sonra helikopteri seren üzerine sabitleyin. «Mekanizma taşıyıcısı» na çubuğu yere paralel tutacak ağırlıkta demir para ekleyin. Sonra kilidi takın.

**RUS** Настройка механизма противовеса.

После сборки всей модели закрепить вертолет на штанге и добавлять в «механизм-обойму» монеты максимального имеющегося диаметра до тех пор, пока штанга не примет горизонтальное положение. После этого установить фиксатор.

**KOR** 평형추 조정.

제품 조립을 완료한 후 축에 헬리콥터를 고정하고 반대편 축에 있는 평형추에 동전을 넣어서 축의 양쪽 무게가 균형을 잡히도록 합니다. 작업이 완료되면 덮개를 고정합니다.

**CHI** 调整配重机构

组装整个模型后，将直升机固定在吊杆上，并将直径尽量大的硬币添加到「机构架」中，直到杆呈水平位置。之后，设置保持器。



**ENG** Configure the swashplate.

There are 4 tensioner rollers for adjustment. Roller No. 1 turn clockwise 6-7 turns, so that the skew machine bends towards the adjustable roller. Compensate roller No. 2 to the horizontal position. Rollers No. 3 and 4 repeat the manipulation, thereby achieving an absolutely flat surface of the bar.

**UKR** Налаштування автомата перекосу.

Для налаштування є 4 ролика - натягувача. Ролик № 1 крутити за годинниковою стрілкою 6-7 оборотів, щоб автомат перекосу нагнувся в сторону регульованого ролика. Роликом № 2 компенсувати до горизонтального положення. Роликами № 3 і 4 повторити маніпуляцію, тим самим домогтися абсолютно рівної поверхні штанги.

**DEU** Ausrichtung des Flugmodells.

Es gibt insgesamt 4 Spannräder zum Verstellen. Rad Nr. 1 im Uhrzeigersinn 6-7 mal drehen, sodass sich die Vorrichtung zur Seite neigt. Rad Nr. 2 gleicht die Schiefe wieder aus bis zur horizontalen Position. Verfahre genauso mit Rad Nr. 3 und anschließend mit Rad Nr. 4, um eine parallele Ausrichtung zu erreichen.

**FRA** Configurez le plateau cyclique.

Il y a 4 rouleaux tendeurs pour le réglage. Tournez le rouleau n°1 dans le sens des aiguilles d'une montre de 6-7 tours, de sorte que la machine s'incline vers ce rouleau. Ensuite compensez à l'aide du rouleau n° 2 pour une position horizontale. Répétez l'opération avec les rouleaux n° 3 et 4 pour obtenir ainsi une surface absolument plate de la barre.

**POL** Konfiguracja tarczy sterującej.

Do ustawienia tarczy służą 4 rolki-napinacze. Należy wykonać 6-7 obrotów rolki nr 1 zgodnie z ruchem wskazówek zegara, aby mechanizm pochylił się w kierunku obracanej rolki. Za pomocą rolki nr 2 przywróć pozycję poziomą. Rolkami nr 3 i 4 powtórz te same czynności, uzyskując w ten sposób absolutnie równą powierzchnię drążka.

**SPA** Configura el plato de giro.

Hay 4 rodillos tensores de ajuste. Rodillo nº1. Gira en el sentido de las agujas del reloj 6-7 giros, para que la máquina inclinada se alinee con el rodillo ajustable. Compensar el rodillo nº 2 en posición horizontal. Repite la manipulación con los rodillos 3 y 4, consiguiendo por lo tanto una superficie totalmente plana de la barra.

**ITA** Configurare il piatto girevole.

Sono disponibili 4 rulli tenditori per la regolazione. Il rullo n. 1 ruota in senso orario 6-7 giri, in modo che la macchina obliqua si pieghi verso il rullo regolabile. Compensare il rullo n. 2 in posizione orizzontale. I rulli n. 3 e 4 ripetono la manipolazione, ottenendo così una superficie assolutamente piatta della barra.

**TUR** Yalpa diskinin konfigürasyonu:

4 adet germe makarası mevcuttur. 1 no'lu makarayı saat yönünde 6-7 tur çevirin; böylece eğme makinası ayarlanabilir çubuğa doğru bükülür. Sonra 2 numaralı makarayı yatay pozisyonu sağlayacak kadar çevirin. 3 ve 4 numaralı makaraları da aynı şekilde çevirerek rot üzerinde tam düz bir yüzey oluşmasını sağlayın.

**RUS** Настройка автомата перекоса.

Для настройки имеется 4 ролика - натяжителя. Ролик № 1 крутить по часовой стрелке 6-7 оборотов, чтоб автомат перекоса нагнулся в сторону регулируемого ролика. Роликом № 2 компенсировать до горизонтального положения. Роликами № 3 и 4 повторить манипуляцию, тем самым добиться абсолютно ровной поверхности штанги.

**KOR** 회전 경사판의 조정

4개의 롤러를 이용하여 회전 경사판을 조정할 수 있습니다. 1번 롤러를 시계 방향으로 6-7회 돌려주면 장치가 롤러쪽으로 기울어집니다. 롤러 2를 이용하여 수평 방향을 보정할 수 있습니다. 3번과 4번 롤러를 반복적으로 조정하여 축이 완전한 수평이 되도록 조절합니다.

**CHI** 设置旋转斜盘。

有4个张紧辊可供调整。1号辊顺时针旋转6-7圈，使歪轮机向调节辊弯曲。旋转2号辊到水平位置。3号和4号辊重复以上操作，从而到达杆的绝对平坦的表面。

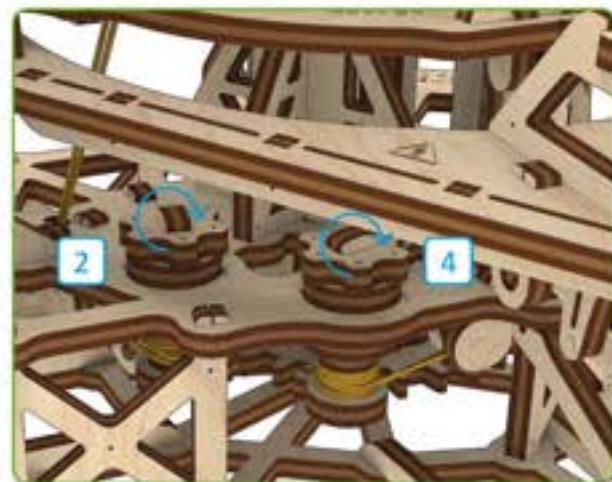

**ENG Attention!**

1. Put the model on a flat surface and make sure that it stands firmly, does not slip.
2. Make sure that the distance from the face to the bar with the model is at least 50 cm, and nothing prevents the free rotation of the model.
3. Pilot the model only in safety glasses!

**UKR Увага!**

1. Встановіть модель на рівну поверхню і переконайтеся, що вона міцно стоїть, не ковзає.
2. Переконайтеся, що відстань від особи до штанги з моделлю становить не менше 50 см, і нічого не заважає вільному обертанню моделі.
3. Пілотувати модель тільки в захисних окулярах!

**DEU Das Modell in Bewegung bringen.**

1. Stelle das Modell auf einen ebenen Untergrund, wo es sicher steht und nicht wegrutschen kann.
2. Achte darauf, dass du einen Abstand von min. 50 cm zum Modell einhältst, um die Bewegung des Modells nicht zu behindern.
3. Bediene das Modell zur Sicherheit mit einer Schutzbrille!

**FRA Attention !**

1. Mettez le modèle sur une surface plane et assurez-vous qu'il soit stable pour qu'il ne puisse pas glisser ou tomber.
2. Assurez-vous que la distance comprise entre votre visage et le modèle est d'au moins 50 cm, et que rien ne puisse gêner sa libre rotation.
3. Pilotez le modèle uniquement avec des lunettes de sécurité!

**POL Uwaga!**

1. Połóż model na równej powierzchni i upewnij się, że jest stabilny i nie ślizga się.
2. Upewnij się, że odległość od osoby do drążka z modelem jest nie mniejsza niż 50 cm i nic nie stoi na przeszkodzie swobodnemu obracaniu się modelu.
3. Steruj modelem tylko w okularach ochronnych!

**SPA ¡Atención !**

1. Coloca el modelo en una superficie plana y estable, para asegurar que se mantiene firme y que no se desliza.
2. Asegurarse de que la distancia de la cara de la barra con el modelo es de al menos 50 cm, y nada impide la rotación libre del modelo.
3. ¡Pilota tu modelo llevando gafas de seguridad!

**ITA Attenzione!**

1. Metti il modello su una superficie piana e assicurati che sia ben saldo, non scivoli.
2. Assicurarsi che la distanza tra la faccia e la barra con il modello sia di almeno 50 cm e che nulla impedisca la rotazione libera del modello.
3. Pilota il modello solo con occhiali di sicurezza!

**TUR Modeli çalıştırın:**

1. Modeli kaymayacak şekilde düz bir yüzeye yerleştirin.
2. Model ile aranızda en az 50cm mesafe bulunsun.
3. Modele sadece güvenlik kafesinin içinde kumanda edin!

**RUS Внимание!**

1. Установите модель на ровную поверхность и убедитесь что она прочно стоит, не скользит.
2. Убедиться, что расстояние от лица до штанги с моделью составляет не менее 50 см, и ничего не мешает свободному вращению модели.
3. Пилотировать модель только в защитных очках!

**KOR 제품의 작동 준비**

1. 제품을 평평한 장소에 위치시키고 미끄러지지 않도록 합니다.
2. 기동과 얼굴은 최소 50cm 이상의 간격을 유지하고 제품의 회전에 방해가 되는 요소는 없는지 확인합니다.
3. 보호 안경을 착용한 후 비행을 시작합니다.

**CHI 启动模型。开始：**

1. 将模型安装在平坦的表面上，并确保其稳固，不会滑动。
2. 确保模型与脸部之间的距离至少为50厘米，并且不妨碍模型的自由旋转。
3. 试驾模型请佩戴护目镜！

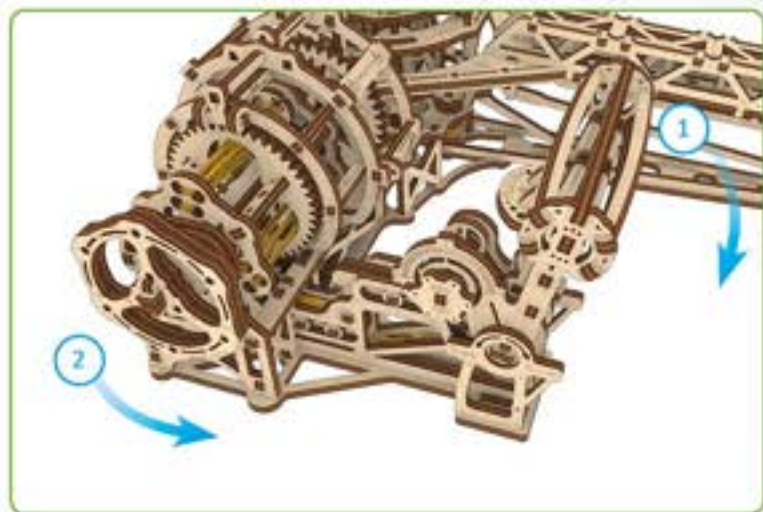

**ENG** Starting the engine.

Bring the «ECK» (Engine Control Knob) to position 1, till you hear the click sound- the «ECK» stopper. Rotate the engine valve No. 2 counter-clockwise 25 half-turns (180 degrees).

**UKR** Заведення двигуна.

Привести «РУД» (Ручка Управління Двигуна) в положення 1, до характерного клацання - стопор «РУД». Обертати , вентиль двигуна № 2 проти годинникової стрілки 25 напівобертів (180 градусів).

**DEU** Starte den Motor.

Stelle den «MKK» (Motor-Kontroll-Knopf) auf Position 1, bis es klickt. Drehe im Anschluss daran das Ventil Nr. 2 insgesamt 25 halbe Drehungen (je 180 Grad) im Uhrzeigersinn.

**FRA** Démarrage du moteur.

Tirez la «PCM» (Poignée de Contrôle du Moteur) en position 1, jusqu'à ce que vous entendiez un clic. Tournez la soupape du moteur n° 2 de 25 tours dans le sens contraire des aiguilles d'une montre (180 degrés).

**POL** Uruchomienie silnika.

Przesuń «PSS» (pokrętło sterowania silnikiem) do pozycji 1, aż do charakterystycznego kliknięcia - stoper "PSS". Wykonaj zaworem silnika nr 2 25 półobrotów przeciwnie do ruchu wskazówek zegara (180 stopni).

**SPA** Arrancando motores.

Lleva el «PM» (La Palanca de Control del motor) a la posición 1, hasta que escuches el click del freno de la misma. Gira la válvula 2 del motor en dirección contraria a las agujas del reloj 25 medios giros (180 grados).

**ITA** Avvio del motore.

Porta la «ECK» (manopola di controllo del motore) in posizione 1, fino a sentire il suono del cli. Ruotare la valvola del motore No. 2 in senso antiorario di 25 mezzi giri (180 gradi).

**TUR** Modelin çalıştırılması:

Motor kontrol düğmesini (ECK) 1 konumuna getirin; tıklama sesi gelmelidir. 2 numaralı motor valfini saat yönünün tersine 25 kez 180 derece çevirin.

**RUS** Заводка двигателя.

Привести «РУД» (Ручка Управления Двигателл) в положение 1 , до характерного щелчка – (стопор «РУД»). Вращать вентиль двигателя № 2 против часовой стрелки 25 полуоборотов (180 градусов).

**KOR** 엔진의 작동 ECK(엔진 조정 노브)를 ECK 스토퍼의 특정한 소리가 날때까지 1위 위치로 이동합니다. 2번의 엔진 밸브를 시계 반대 방향으로 25회(180도 기준) 감아 줍니다.

**CHI** 启动发动机。将«ECK» ( 发动机控制旋钮 ) 置于位置1 , 直到特有的点击 - «ECK»制动器。逆时针旋转2号发动机气门25个半圈 ( 每半圈为180度 )。

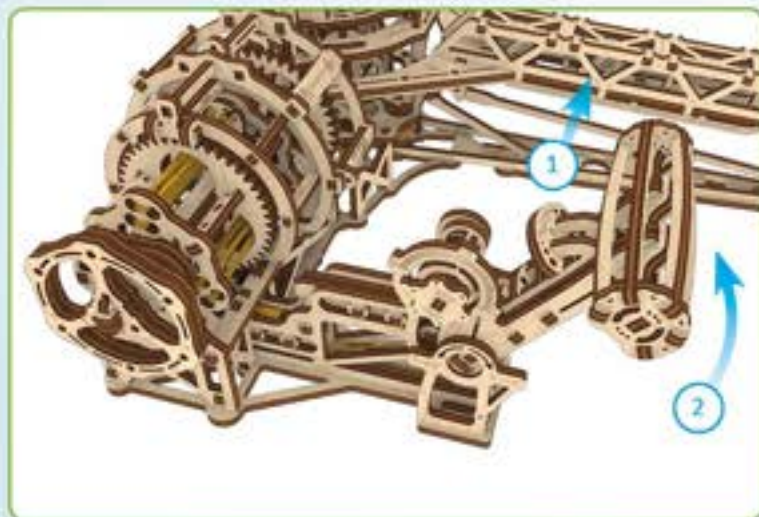
**ENG** Launching the model.

On the «ECK» pull up the trigger with the inscription «Pull Up» and slowly, smoothly move the «ECK» to position 2, thereby regulating the rotation speed of the engine.

**UKR** Запуск моделі.

На «РУД» потягнути вгору спусковий механізм з підписом «Pull Up» і повільним, плавним рухом приводити «РУД» в положення 2, регулюючи тим самим обороти двигуна

**DEU** Starte das Modell.

Ziehe den Auslöser mit der Aufschrift «Pull Up» am «MCK» nach oben. Langsam und gleichmäßig bis auf Position 2 und reguliere so die Motordrehzahl.

**FRA** Lancement du modèle.

Sur la «PCM», tirez sur la gâchette avec l'inscription « Pull Up » et déplacez doucement la «PCM» en position 2, en réglant ainsi la vitesse de rotation du moteur.

**POL** Uruchomienie modelu.

Na «PSS» pociągnij do góry spust z napisem «Pull Up» i powolnym, płynnym ruchem ustaw «PSS» w pozycji nr 2, regulując w taki sposób prędkość obrotów silnika.

**SPA** Despegando el modelo.

Con la «PM», levanta el gatillo con la inscripción «Pull Up» y lenta y suavemente mueve la «PM» a la posición 2, regulando la velocidad de giro del motor.

**ITA** Avvio del modello.

Sulla «ECK» sollevare il grilletto con la scritta «Pull Up» e spostare lentamente, con cura, «ECK» sulla posizione 2, regolando in tal modo la velocità di rotazione del motore.

**TUR** Modelin başlatılması:

ECK üzerindeki «Pull up» yazan mandalı yukarı çekin ve ECK'yi yavaşça 2 konumuna getirerek, motorun dönüş hızını düzenleyin.

**RUS** Запуск модели.

На «РУД» потянуть вверх спусковой механизм с надписью «Pull Up» и медленным, плавным движением приводить «РУД» в положение 2, регулируя тем самым обороты вращения двигателя.

**KOR** 제품의 작동 «ECK»에서 «Pull Up»이라는 문자가 있는 트리거를 위로 천천히 부드럽게 당겨 위치 2로 이동하며 엔진 회전 속도를 조절합니다.

**CHI** 启动模型。在«ECK»上拉触发器并带有题词«上拉»并缓慢地平稳地移动«ECK»到位置2，从而调节发动机的转速。



**ENG «RPM Module»** The maximum speed limit of the engine is limited in the form of an sheave. With the knob on the «0» mark, the engine speed is reduced to the minimum speed, and when the handle is at the «150» mark, the engine speed is reduced to the maximum engine speed. By adjusting the «RPM Module» handle, you can achieve the ideal engine speed for each of the proposed aircraft models.

**UKR «RPM Module»** Обмеження максимальної швидкості обертів двигуна виконано у формі ексцентрика. При положенні ручки на позначці «0» оберти двигуна зводяться до мінімальної швидкості оборотів, а при положенні ручки на позначці «150» оберти двигуна зводяться до максимальної швидкості обертів двигуна. Регулюючи рукоятку «RPM Module» можна досягти ідеальної швидкості обертів двигуна для кожної із запропонованих моделей літальних апаратів.

**DEU Das «RPM» Modul.** Die maximale Geschwindigkeit wird mittels eines Reglers begrenzt. Stellt man den Kopf auf «0», so dreht der Motor auf minimaler Leistung. Stellt man den Knopf hingegen auf «150», so dreht die Maschine mit voller Leistung. Verstelle den Regler, um die gewünschte Geschwindigkeit einzustellen.

**FRA Module RPM** La vitesse maximale du moteur est limitée sous la forme d'une poulie. Si l'aiguille est sur le «0», cela indique que la vitesse du moteur est au minimum, et si elle indique «150», cela indique que la vitesse du moteur est au maximum. C'est en ajustant le module RPM que vous pourrez atteindre la vitesse idéale suivant l'appareil installé sur votre modèle.

**POL «RPM Module»** Ograniczenie maksymalnej prędkości obrotów silnika zostało wykonane w postaci mimośrodów. Przy ustawieniu pokrętki w pozycji «0» prędkość obrotów silnika jest minimalna, a przy ustawieniu pokrętki w pozycji «150» prędkość obrotów silnika jest maksymalna. Obracając pokrętkę «RPM Module», możesz osiągnąć idealną prędkość obrotów silnika dla każdego z proponowanych modeli.

**SPA «Módulo RPM».** El límite máximo de velocidad del motor se limita en la forma de una roldana. Con la palanca en la posición «0», la velocidad del motor se reduce al mínimo, mientras que en la posición «150», se ajusta la velocidad del motor al máximo. Ajustando el módulo RPM, puedes conseguir la velocidad ideal del motor según cada modelo de aviación.

**ITA «Modulo RPM».** Il limite di velocità massima del motore è limitato sotto forma di una puleggia. Con la manopola sul segno «0», il regime del motore viene ridotto alla velocità minima e quando la maniglia si trova sul contrassegno «150», il regime del motore viene ridotto al regime massimo del motore. Regolando la manopola «RPM Module», è possibile ottenere il regime motore ideale per ciascuno dei modelli di aeromodelli proposti.

**TUR RPM modülü:** Motorun hızı düğme «0» konumundayken minimum, 150 konumundayken maksimumdur. «RPM Modülü» kolunu ayarlayarak, önerilen uçak modellerinin her biri için ideal motor hızını elde edebilirsiniz.

**RUS «RPM Module»** Ограничение максимальной скорости оборотов двигателя выполнено в форме эксцентрика. При положении ручки на метке «0» обороты двигателя сводятся к минимальной скорости оборотов, а при положении ручки на метке «150» обороты двигателя сводятся к максимальной скорости оборотов двигателя. Регулируя рукоять «RPM Module» можно достичь идеальной скорости оборотов двигателя для каждой из предлагаемых моделей летательных аппаратов.

**KOR RPM 모듈** 엔진의 최대 속도 제한은 편심의 형태로 제한됩니다. 지침이 «0» 표시에 있으면 엔진 속도가 최소 속도로 감소하고 지침이 «150» 표시에 있으면 엔진 속도가 최대 엔진 속도가 됩니다. «RPM 모듈» 핸들을 조정하면 각 항공기 모델의 이상적인 엔진 속도를 설정할 수 있습니다.

**CHI «RPM模块»** 发动机的最高转速限制是以偏心轮的形式进行限制的。通过«0»标记上的旋钮，发动机转速降至最低转速，当手柄处于«150»标记时，发动机转速至最高转速。通过调整«RPM模块»手柄，可以为每架飞机模型实现理想的发动机转速。

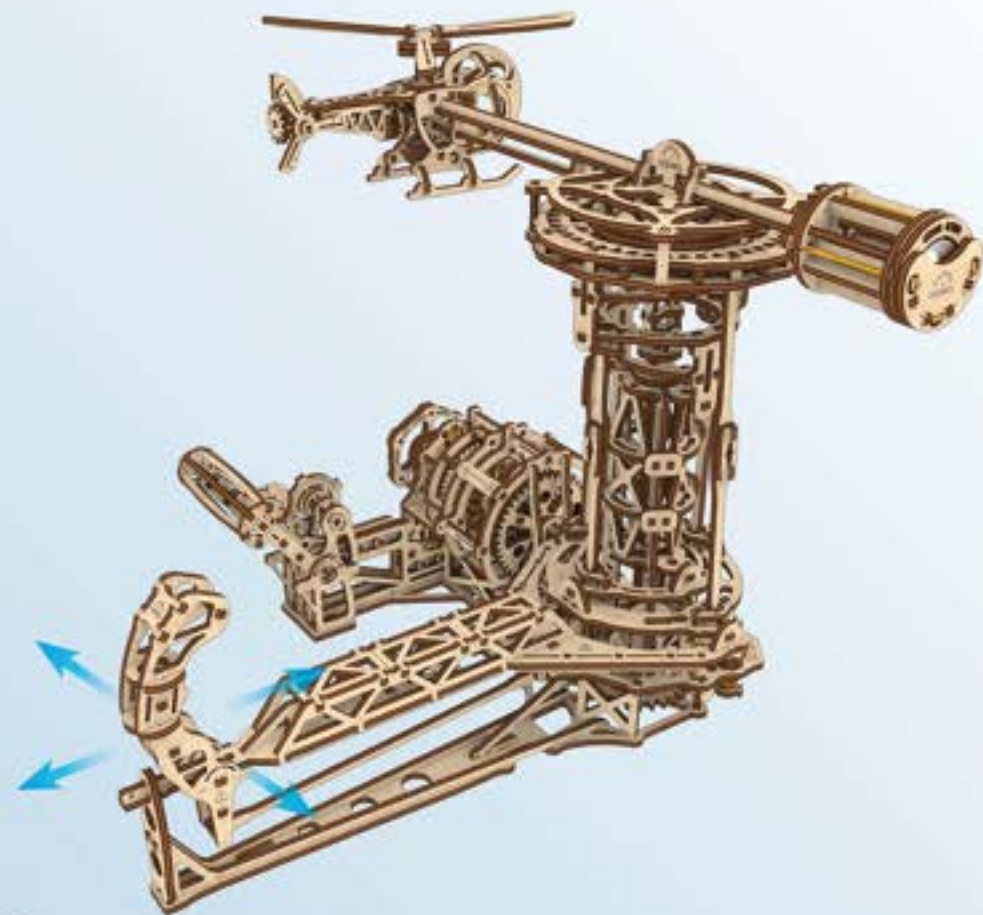
**ENG** Steering wheel control.

After starting the engine, hold the control gear in neutral by the steering wheel. The steering wheel makes it possible to control the aircraft and set it at the desired flight path.

**UKR** Управління штурвалом.

Після запуску двигуна, штурвалом управління утримувати літальний апарат в нейтральному положенні. Штурвал дає можливість управляти літальним апаратом і задавати йому потрібну траєкторію польоту.

**DEU** Bedienung des Steuerknüppels.

Nachdem der Motor gestartet wurde, halte das Flugmodell in neutraler Position. Mit dem Steuerknüppel wird das Flugmodell in die gewünschte Richtung manövriert.

**FRA** Manche directionnel.

Après le démarrage du moteur, maintenez le manche au point mort avant de le bouger. Le manche permet de contrôler trajectoire de vol souhaitée.

**POL** Sterowanie kierownicą.

Po uruchomieniu silnika za pomocą kierownicy utrzymuj urządzenie w pozycji neutralnej. Kierownica umożliwia sterowanie aparatem latającym i ustawienie pożądanego trajektorii lotu.

**SPA** Volante de conducción. Tras arrancar el modelo, mantén el motor en posición neutral con el volante de conducción. El volante de conducción hace posible controlar el modelo y fijarlo en la ruta de vuelo deseada.

**ITA** Controllo del volante. Dopo aver avviato il motore, tenere il cambio in folle dal volante. Il volante consente di controllare l'aeromobile e impostarlo sulla traiettoria di volo desiderata.

**TUR** Direksiyon kontrolü:

Motoru çalıştırdıktan sonra, kontrol dişlisini direksiyondan nötral konuma getirin. Direksiyon, uçağı kontrolünü etmeyi ve istenen rotada tutmayı sağlar.

**RUS** Управление штурвалом.

После запуска двигателя, штурвалом управления удерживать летательный аппарат в нейтральном положении. Штурвал дает возможность управлять летательным аппаратом и задавать ему нужную траекторию полета.

**KOR** 조향 레버 제어

엔진이 작동한 이후에는 조향 레버의 제어 기어를 중립에 두십시오. 조향 레버은 항공기를 제어하고 원하는 비행 경로로 설정할 수 있도록 해 줍니다.

**CHI** 方向盘控制。

启动发动机后，用方向盘将控制器保持在空档位置。方向盘可以控制飞机并将其设置在所期望的航向。

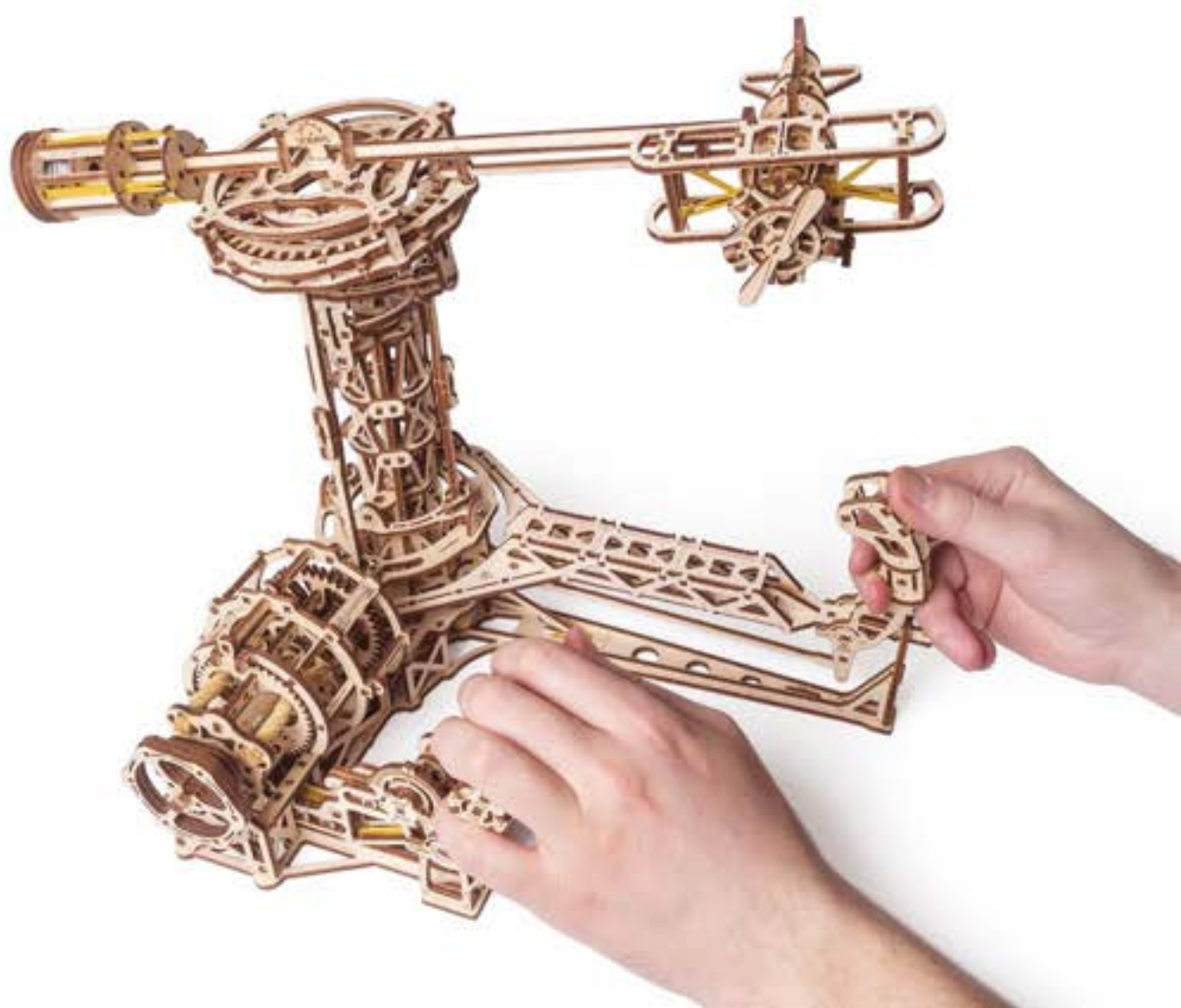
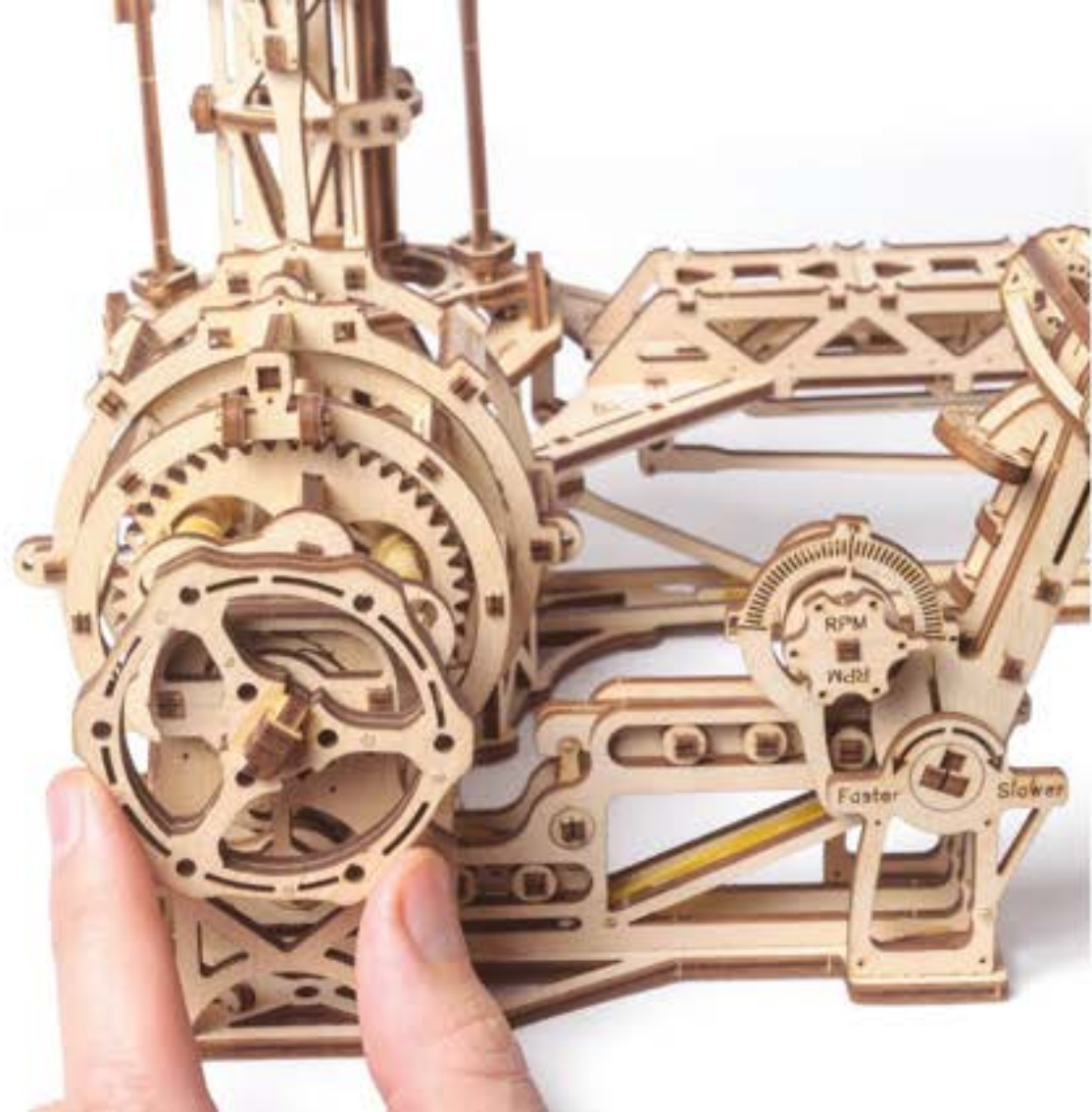



1

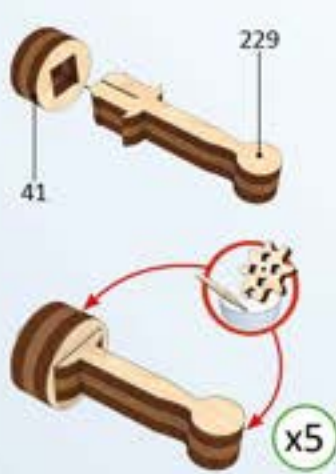

2



3



4



5



6

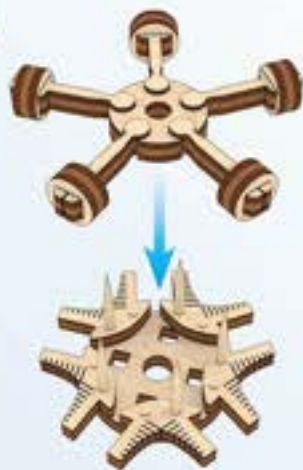

7



8



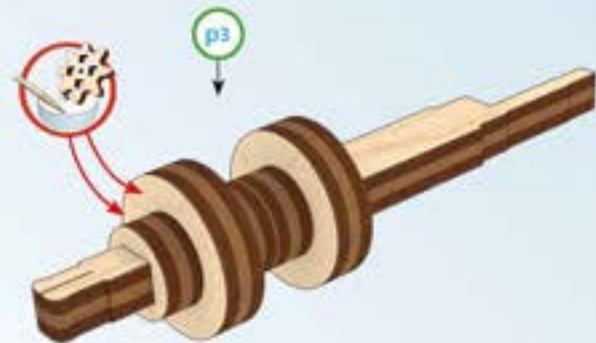
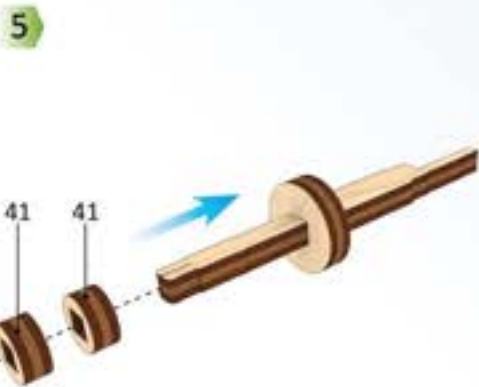
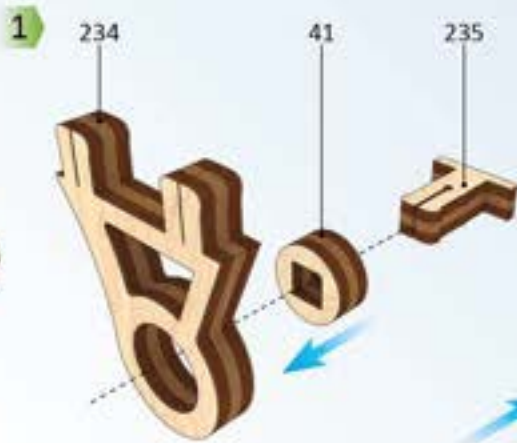

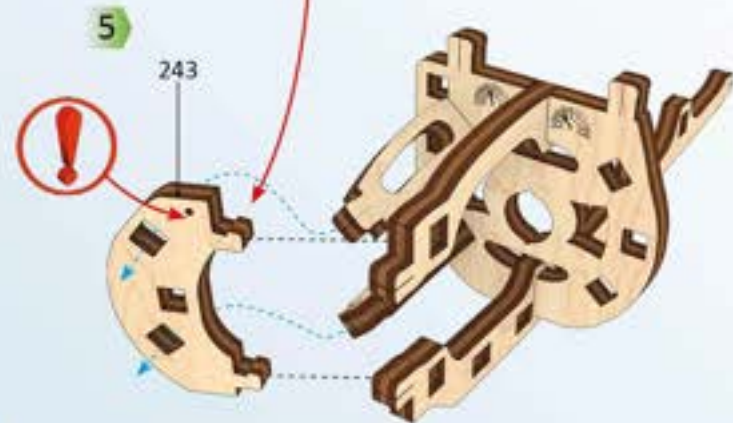
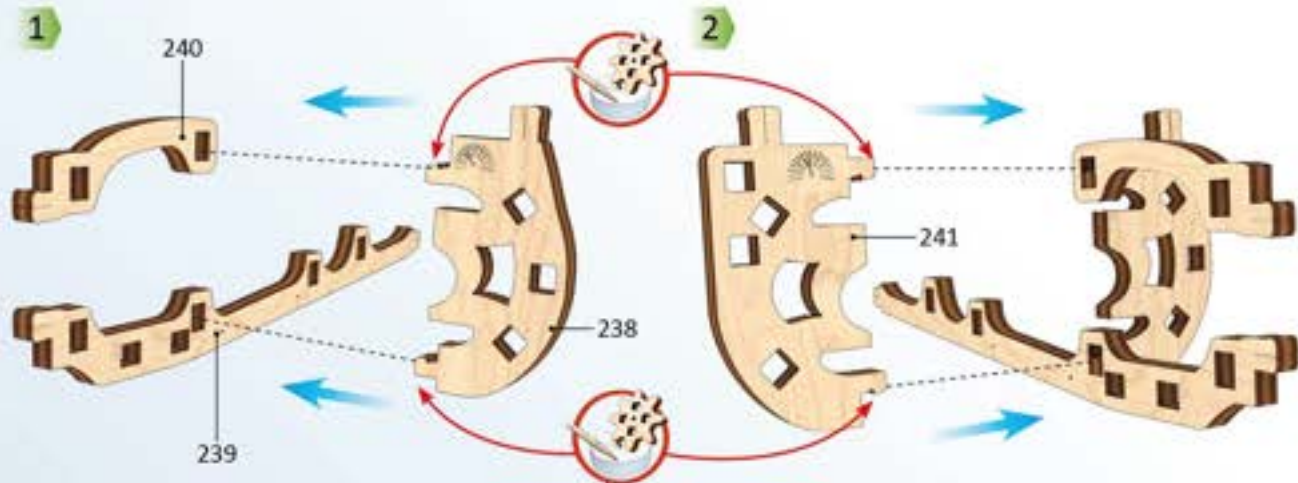



1

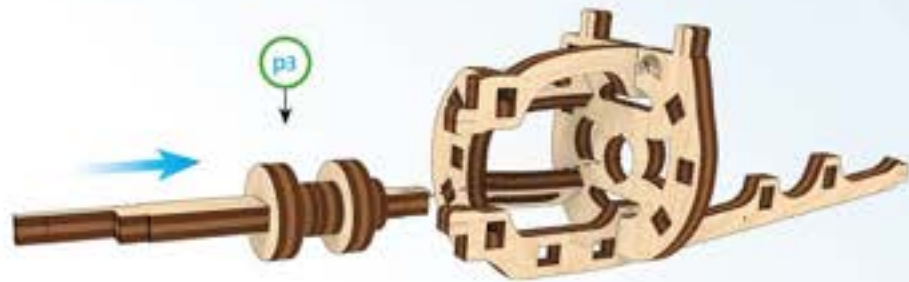

2

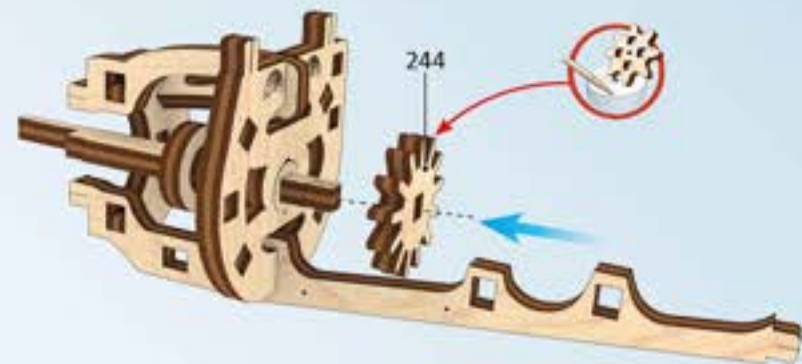

3

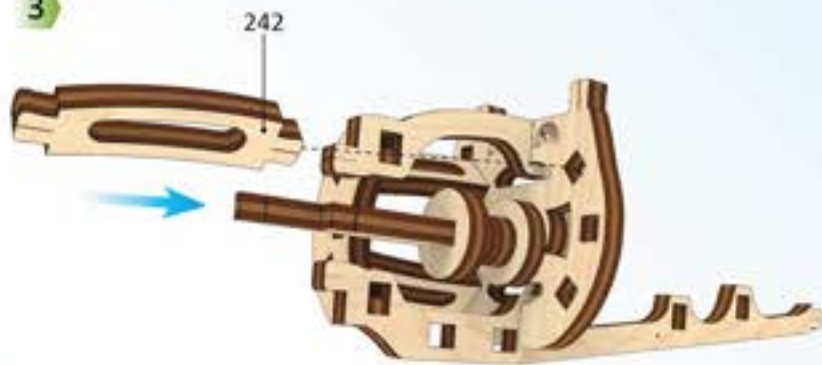

4

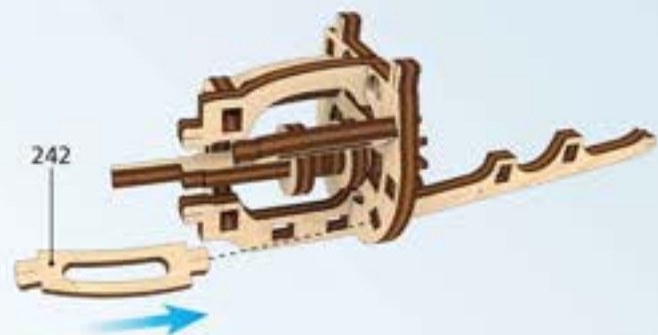



1

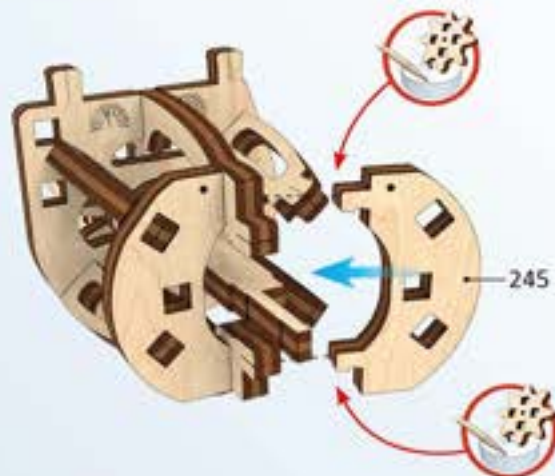

2

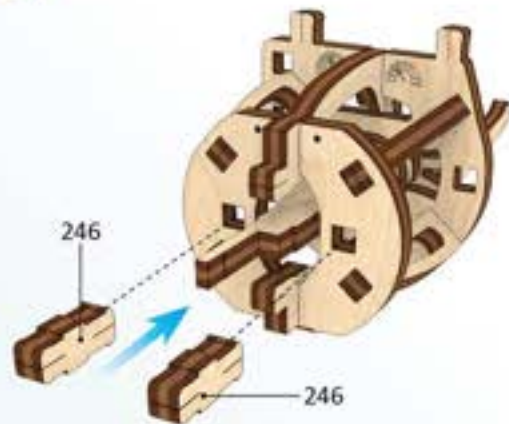

3



4

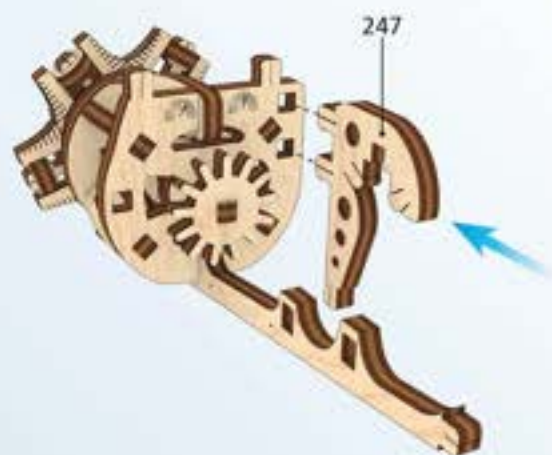

5

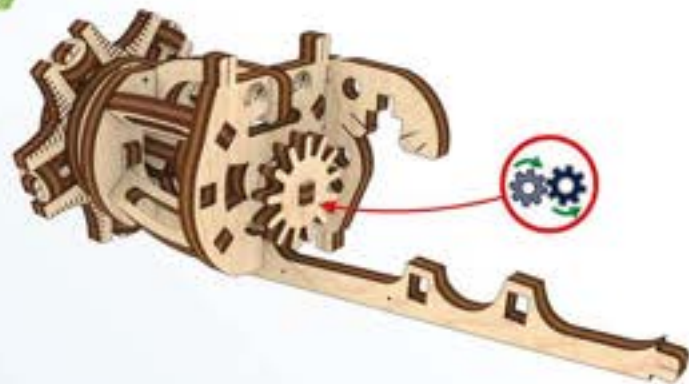



1



2

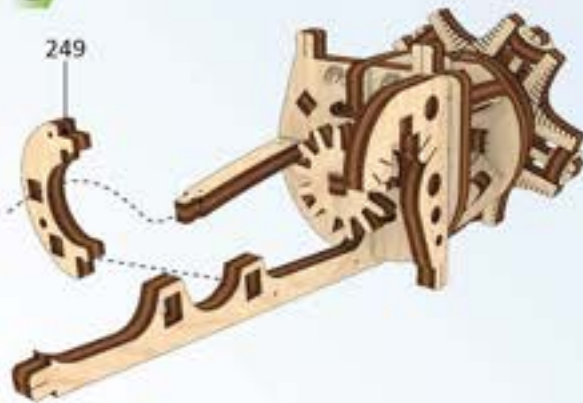

3

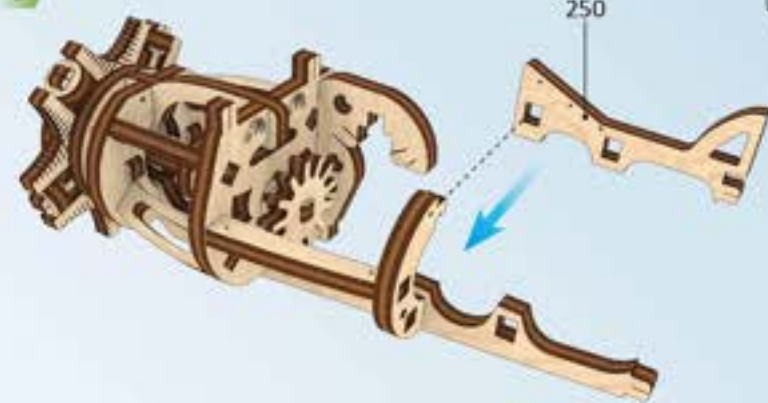

4

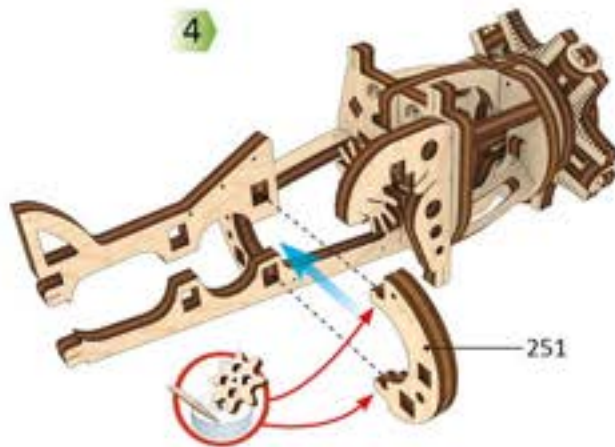

5

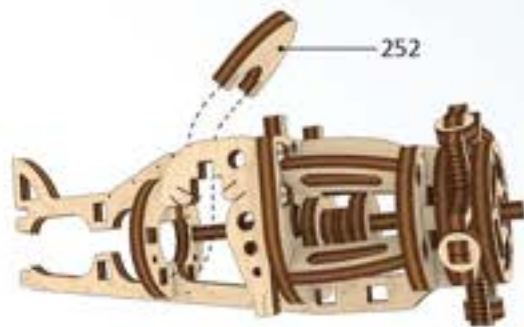



50



50

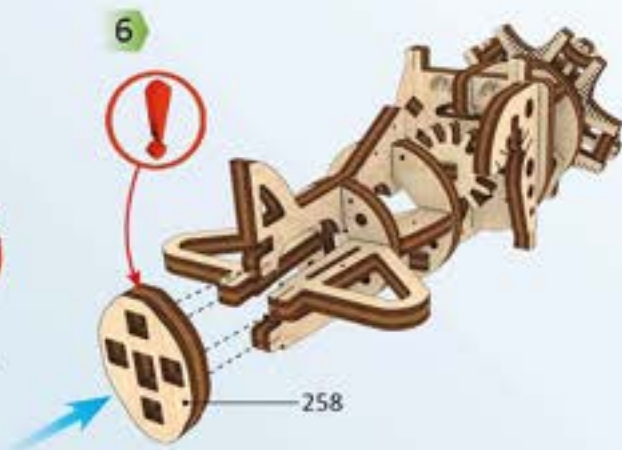
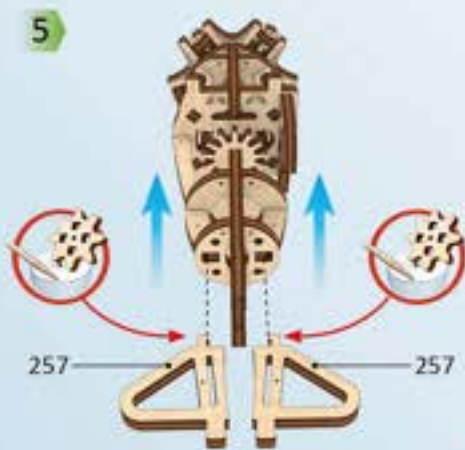



1

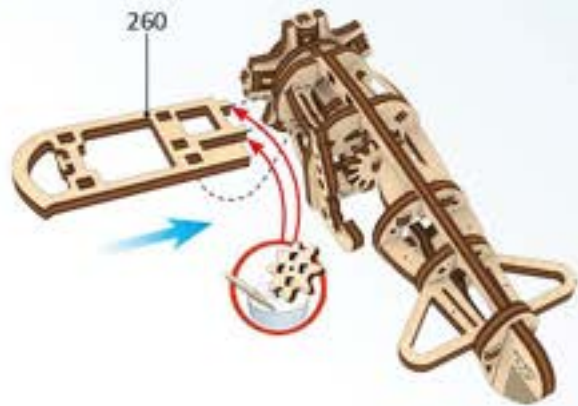

2



3

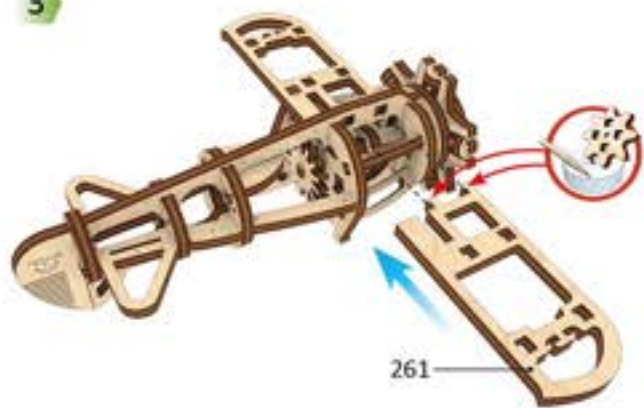

4

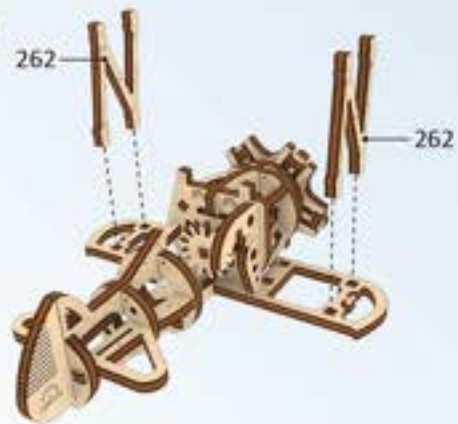



1

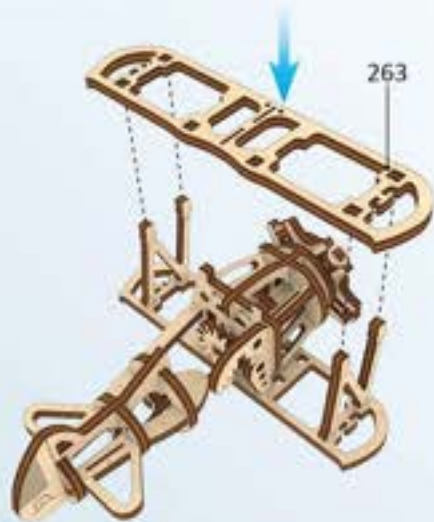

263



2



p2

3

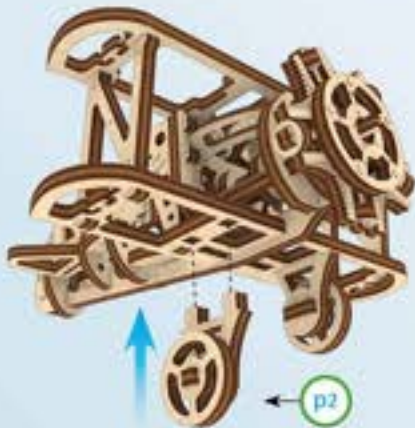

p2



4

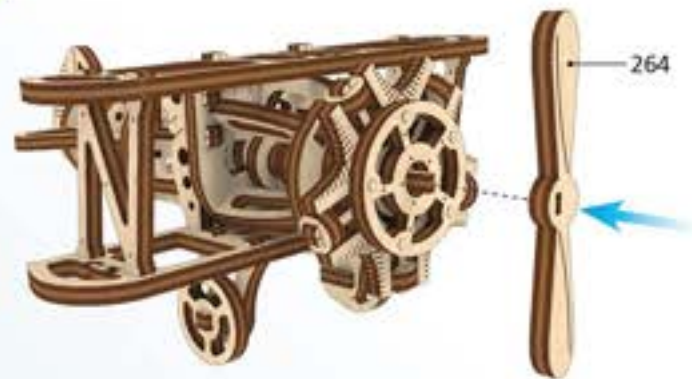

264

1

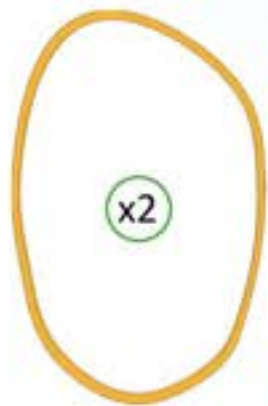

2



3



4

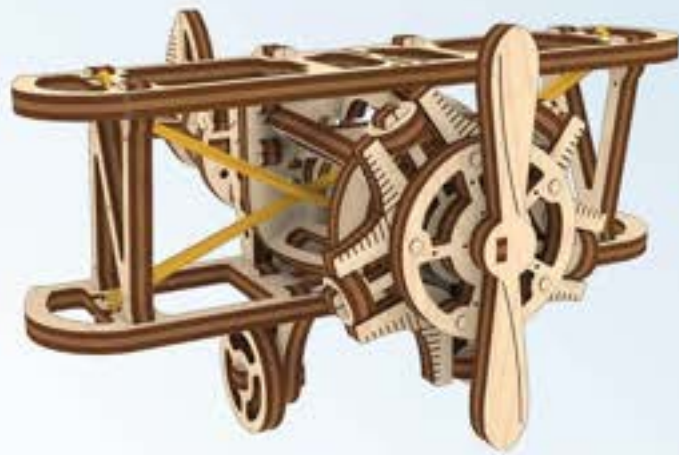



ENG Thanks for following along on this journey with us. UKR Дякуємо, що ви пройшли цей шлях з нами. DEU Vielen Dank, dass Sie diesen Weg mit uns gegangen sind. FRA Merci denous avoir accompagnés tout au long de ces étapes. POL Dziękujemy, że razem z nami pokonałeś tę drogę! SPA Gracias por haber recorrido el camino con nosotros. ITA Grazie per aver fatto uesto percorso con noi. TUR Bizimle bu yolu geçtiniz için teşekkür ederiz. RUS Спасибо, что вы прошли этот путь с нами. KOR UGEARS와 함께해 주셔서 감사합니다. CHI 感谢您参与有趣的模型配装过程。

[ugearsmodels.com](http://ugearsmodels.com)